

# CONTENTS

TOWING CODE



PREPARING FOR THE ROAD



ON THE ROAD



FIRE & SAFETY



SERVICES



ELECTRICS



FITTED EQUIPMENT



AL-KO CHASSIS & TYRES



GENERAL DATA



# INTRODUCTION

## INTRODUCTION

Lunar Caravans Ltd welcomes you as you join the ranks of owners of Venus Caravans. We hope you will enjoy your caravan and this handbook tells you how to look after it so that it may give you years of pleasure and enjoyment.

Remember that it is a vehicle and thus calls for a small amount of regular maintenance.

**You are requested to contact your dealer on all enquiries in order to ensure satisfaction. You will only experience delays if you bypass the normal channels.**

Your Venus Caravan has been European Commission Whole Vehicle Type approved via LuxControl and has also been inspected by the National Caravan Council (NCC) to ensure your new caravan is compliant and safe to use.

Your Venus caravan has been built and approved to EN1645 which applies to a large number of features such as:

- sizes of beds
- escape factor i.e. windows and exterior door
- materials
- design and construction

- insulation is grade 3 classified which is able to achieve an average temperature difference of 35 degrees centigrade between interior and exterior when the exterior is -15 degrees centigrade
- electrical equipment, both 12 volt and 230 volt
- chassis
- undergear
- drawbar
- jockey wheel
- wheels and tyres
- installation of gas
- ventilation
- awnings and channel
- fire notices
- handbook

Touring caravans are designated by their model year which runs from 1 September to 31 August. A new year model can only be registered by CRIS from 1st September onwards.

This caravan has been security marked and recorded under the Caravan Registration and Identifications Scheme that is organised by the Caravan Industry.

Please see Cris, General Data section, page 113 on how your caravan can be uniquely identified.

To protect yourself and your touring caravan, never leave the Registration Document in the caravan. For security reasons keep it in a safe place.

---

*Disclaimer: The contents of this Handbook book are as accurate as possible at the time of going to print. Lunar Caravans reserve the right to alter materials and specifications without prior notice. Venus Caravans is a brand of Lunar Caravans Ltd.*



# TOWING CODE

Scope of Code .....	4
Caravan Terms .....	4
Weights .....	4
Towing Vehicle Terms .....	4
Measurement of Noseweight .....	6



# TOWING CODE

## THE CARAVAN TOWING CODE

### Industry Payload Standard for UK touring Caravans

This standard has been prepared by the National Caravan Council and formulated with input from Industry Experts. The standard applies to UK specification Touring Caravans and will apply for the NCC certification from 2011 onwards model year Touring Caravans.

For the 2012 model year the method of calculating the Mass in Running Order (MRO) and user payload figures are in line with European Vehicle Directives and provides for the requirements for European Whole Vehicle Type Approval EWVTA, 2007/46/EC (The Framework Directive) and the directives referenced therein.

### Other Notable Weights/Capacities

- 1) 9kg of water in the water heater.
- 2) 2kg of water in the toilet holding tank (this is the maximum recommended by Theftford).
- 3) The weight of the spare wheel is 17.5kg.

## DEFINITIONS

### Maximum Technically Permissible Laden Mass (MTPLM)

The fully laden mass of the caravan in the manufacturer's standard specification which is stated in the manufacturer publications by the manufacturer for tow car matching. This mass takes into account the specific operating conditions including factors such as the strength of the materials, load capacity of the tyres etc, and can be found on a plate affixed to the caravan, usually near the entrance door.

Please note: The MTPLM is the maximum weight that the caravan can be loaded to, this mass must NOT be exceeded. However most models can have the MTPLM upgraded in capacity; this must be approved by Lunar Caravans Ltd via the dealership. Please contact your dealership for further details.

### Mass In Running Order (MIRO) or (MRO)

This is the weight of the caravan as it leaves our factory (inclusive of the electrical hook-up cable at 6kg and the winding handle at 1kg) plus the following:

8kg allowance for gas bottles.

**Note:** The MRO is calculated with the water tanks empty, any water in the tanks during travel must be accounted for in the user payload. It is also advisable to empty such tanks prior to transit.

### User Payload (UP)

The difference between the MIRO and MTPLM (excluding potential MTPLM upgrade). The user payload allows for items common to all occupants, such as food, cutlery, pots, pans, clothing, footwear, bedding, sports equipment etc. The user payload also includes an allowance for the auxiliary battery.

The UP is calculated by the following formula:

$$10L + 10N + 50.$$

L is the body length of the caravan in meters.

N is the number of berths.

50 is for normal equipment carried in the caravan, a sample list is given below.

TV .....	3kg
Kettle .....	0.5kg
Bed linen .....	6kg
Crockery .....	5kg
Saucepans .....	3kg
Wastemaster .....	6kg
Aquaroll (empty) .....	5kg
Waste bin .....	1kg
Cutlery .....	2kg
Toilet fluid etc .....	2.5kg
Battery .....	16kg



## Optional Equipment Payload (OEP)

Items made available by the manufacturer over and above the standard specification for the caravan in addition to the user payload.

## Personal Effects Payload (PEP)

A mass specified for the items which a user can choose to carry in a caravan and which are not included as an essential habitation equipment or optional equipment.

Optional Item	Additional Weight
---------------	-------------------

R/C Alarm/Awning Light .....	1 kg
AL-KO Secure wheel locks (per lock) ....	2 kg
AI-KO ATC Trailer Control .....	2 kg
Air Conditioning .....	30 kg

**Please note:** Any options fitted by retailer will reduce the overall payload available to the customer.

## REGULATORY AND SAFETY ADVICE

**WARNING:** UNDER NO CIRCUMSTANCES SHOULD THE MAXIMUM TECHNICALLY PERMISSIBLE LADEN MASS (MTPLM) BE EXCEEDED. PLEASE TAKE CARE TO ENSURE THAT YOU HAVE ALLOWED FOR MASSES OF ALL ITEMS YOU INTEND TO CARRY IN THE CARAVAN e.g. Optional equipment and personal effects such as clothing, food, pets, bicycles, sailboards, sports equipment etc.

THE MASS OF THE CARAVAN IN RUNNING ORDER (MIRO) CONTAINS PROVISION FOR THE MASSES OF LIQUIDS, GAS ETC. PART OF THIS PROVISION CAN ALSO BE UTILIZED AS ADDITIONAL PAYLOAD IF FOR EXAMPLE YOU WISH TO TRAVEL WITH NO GAS CYLINDERS.

## THE CARAVAN AND TOWING VEHICLE RATIO

This can be determined by calculation and is equal to:

$$\frac{\text{actual laden weight of caravan}}{\text{kerb weight of towing vehicle}} \times 100\%$$

THE **LAW** REQUIRES THAT CARAVANS & THEIR TOWING VEHICLES & THE LOADS THEY CARRY MUST BE IN SUCH A CONDITION THAT NO DANGER OR NUISANCE IS CAUSED.

(Regulation 100 of the Road and Vehicles [Construction and Use] Regulations 1986).

### IMPORTANT NOTICE:

Your caravan has been designed and manufactured for towing behind normal road cars. Additional care should be taken when towing with a 4x4 due to the 'off-road' nature of the suspension. Caravans are not suitable for towing behind commercial vehicles.



## TOWING CODE

### POWER TO WEIGHT RATIO:

No hard and fast rules can be stated but, here is a general guide.

- (a) Conventional petrol engines with a capacity up to approximately 1500 cc should be adequate for towing a caravan weighing around 85% of the kerb weight of the towing vehicle.
- (b) Above 1500 cc such engines should manage a caravan weighing up to 100% of the kerb weight of the towing vehicle and still give adequate performance.

**Note:** The towing vehicle manufacturer's limit is, in some cases, less than the kerb weight.

Vehicles with automatic transmission may need an oil cooler to be fitted or the SAE rating of the gearbox oil increased when towing. The advice of the vehicle manufacturer should be sought.

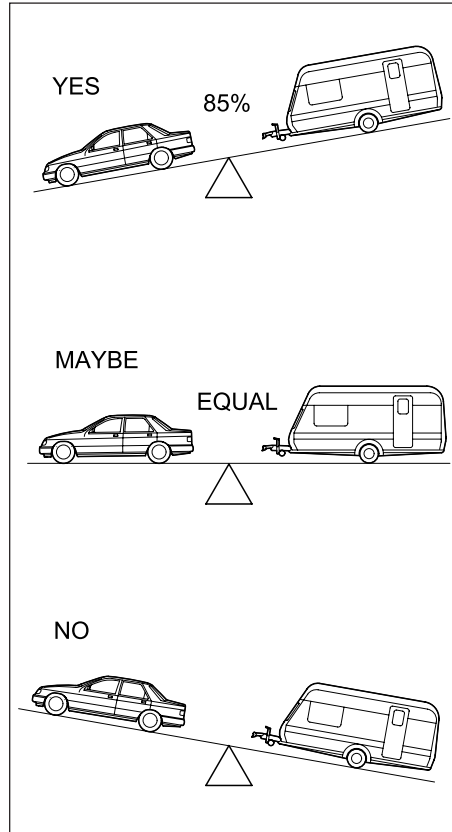

### MEASUREMENT OF NOSEWEIGHT

Towing noseweight should be a minimum of 50kg and heavier for twin axle models. This may be measured using a proprietary brand of noseweight indicator. Such equipment is obtainable at your Venus Caravan Dealer.

Another simple method is to use bathroom scales under the coupling head with a piece of wood fitted between the coupling head and the scales, of such length that the caravan floor is horizontal with the jockey wheel raised.

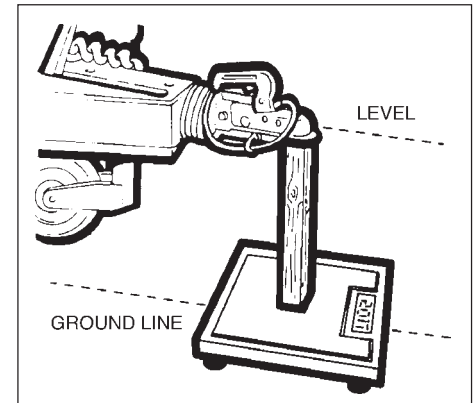



# PREPARING FOR THE ROAD

Checklist .....	8
Loading and Distribution .....	8
Stability .....	9
Pre-Tow Checklist .....	10
Stabiliser .....	12
Wheel Lock .....	16
Breakaway Cable .....	20
Tyres .....	22



## PREPARING FOR THE ROAD

### PRE-LOAD CHECKLIST

**CAUTION: Never enter the caravan without first lowering the four corner steadies with the brace provided.**

#### CHECK THAT:

- loose articles are stowed securely. Do not stow tins, bottles or heavy items in overhead lockers prior to towing.
- all lockers and cupboard doors are closed and secured.
- all bunks are secure.
- all rooflights are closed and secured.
- main table is stored in its transit position.
- fridge is on 12v operation and door lock is set.
- all windows are fully closed and latched. Never tow with windows on nightsetting. Leave all curtains and blinds open to aid rear visibility.
- gas cylinders are correctly positioned, secured and turned off.
- battery is secure.
- wheelnuts for tightness.
- tyre pressures and condition of tyres.

### LOADING AND DISTRIBUTION OF WEIGHT IN THE CARAVAN

Do not exceed recommended maximum loading for your caravan.

1. Load heavy items low down near the floor and mainly over or in front of the axle(s).
2. Load evenly right to left.
3. Do not load items at the extreme rear since this can lead to instability due to the 'pendulum effect'.
4. Load remainder to give a suitable noseweight at the towing coupling.
5. Check noseweight. (Lunar Caravans are designed to be towed with a minimum noseweight of 50kg and heavier for twin axle models) (See page 4).

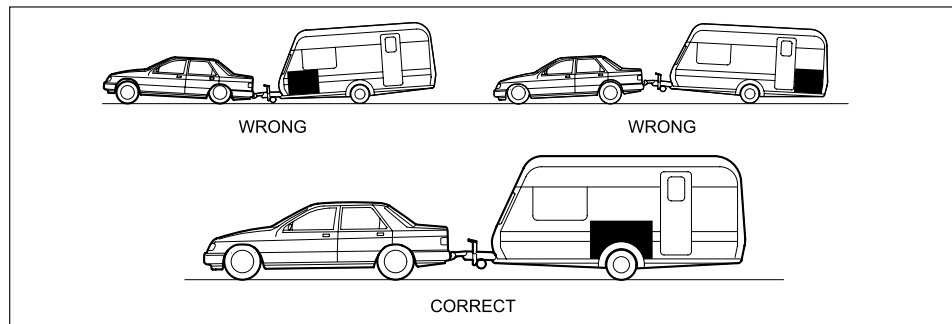
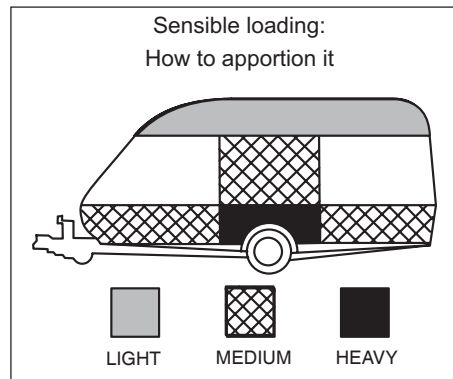

**Note: Do not load car boot heavily.**





## STABILITY

The most common causes of poor stability include:

- (a) Incorrect tyre pressures on car or caravan.
- (b) Worn springs or loose spring fixings on the towing vehicle.
- (c) Towing vehicle shock absorbers too soft.
- (d) Insufficient noseweight.
- (e) Nose of caravan is towing too high.
- (f) Incorrect loading

**Stabilisers.** There are many proprietary brands of stabiliser available. Your Lunar dealer will be pleased to advise you of the most suitable. They are an aid to stability and should not be considered as a cure for a stability problem.

**Note:** It is expressly forbidden by the chassis manufacturer for holes to be drilled into the 'A' frame to accommodate a stabiliser bracket. A clamp must be used. Similarly, holes should not be drilled into the coupling head.

## Towing vehicle's rear suspension

It is important that the towing vehicle's rear suspension is not deflected excessively by the noseweight on the tow ball. If it is excessive the steering and stability will be affected.

The greater the towing vehicle's tail overhang (the distance between the rear axle and the tow ball) the greater the effect the noseweight will have on the towing vehicle's rear suspension.

After trying out the caravan it may be found that stiffening of the rear suspension is necessary — but note that this may give the towing vehicle a firmer ride when not towing.

There are a number of suspension aids available and advice should be sought on which to use and how to fit.

It is important to ensure that the caravan is towed either level or slightly nose down.

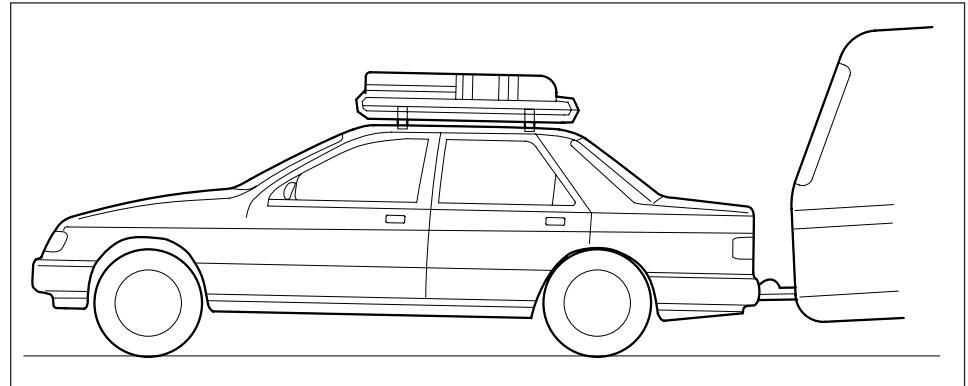

Illustration of excessive deflection of vehicle's rear suspension



## PREPARING FOR THE ROAD

### PRE-TOW CHECKLIST

1. Check that the hitch is securely coupled onto the towball and connect the breakaway cable. Your hitch height should be around 440mm (17") to the centre of the towball when the towing vehicle and caravan are coupled and laden.
2. The Jockey wheel should be raised and tightly clamped or removed completely if desired.
3. Corner steadies must be wound up fully.
4. Plug in the electrical connection to the car, keeping the cable clear of the road and check the operation of lights.
5. Release the handbrake. "Failure to ensure that the handbrake is completely off, can result in overheating of the brakes and failure of the bearings".
6. Check tyre pressure with cold tyres (see specification). Wheel bolt torque settings (see chart on page 11).
7. Adjust the tyre pressures of your tow car to the manufacturers recommendations for full loads.
8. Engage the stabiliser, if fitted.
9. Fit towing mirrors to your car.

Where access to an internet connection is available please refer to the manufacturer's full operating instructions: [www.al-ko.co.uk/pages/original-2.html](http://www.al-ko.co.uk/pages/original-2.html)

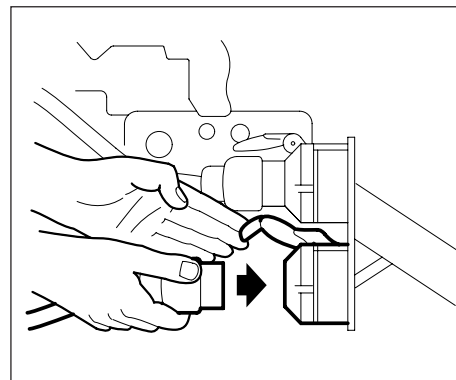
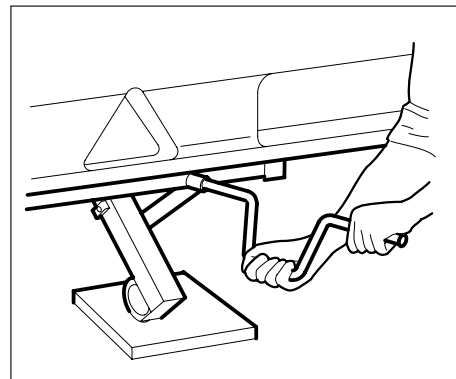
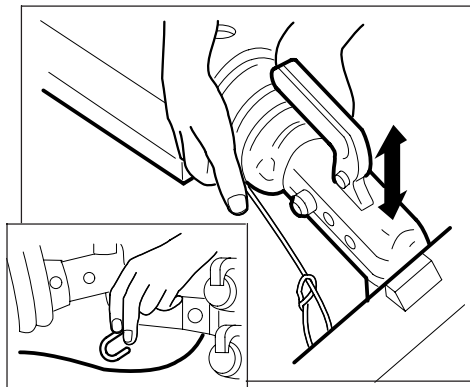



## Wheel/Tyre combinations



Assembly 1 - Quasar/Lexon/Stellar (Single Axles)	
Torque Setting / Bolt Spec	95Nm / M12 x 1.5 (26mm thread) Tensile Strength 10.9, 60 degree conical fixing, 19mm hexagon bolt head.
Tyre Pressure	See Model
Tyre Size	185 R14 C
Wheel Description	SY262 Hyper Silver



Assembly 3 - Clubman (Single Axles) + Dealer Specials	
Torque Setting / Bolt Spec	95Nm / M12 x 1.5 (26mm thread) Tensile Strength 10.9, 60 degree conical fixing, 19mm hexagon bolt head.
Tyre Pressure	See Model
Tyre Size	185 R14 C
Wheel Description	SY262 Black Polish



Assembly 5 - Venus (Single Axles)	
Torque Setting / Bolt Spec	95Nm / M12 x 1.5 (26mm thread) Tensile Strength 10.9, 60 degree conical fixing, 19mm hexagon bolt head.
Tyre Pressure	See Model
Tyre Size	185 R14 C
Wheel Description	SY934 Gunmetal Grey



Assembly 2 - Quasar/Lexon/Stellar (Twin Axles) & Ariva (Single Axle)	
Torque Setting / Bolt Spec	95Nm / M12 x 1.5 (26mm thread) Tensile Strength 10.9, 60 degree conical fixing, 19mm hexagon bolt head.
Tyre Pressure	See Model
Tyre Size	185 R14 C
Wheel Description	SY262 Hyper Silver



Assembly 4 - Delta (Twin Axles) + Dealer Specials	
Torque Setting / Bolt Spec	95Nm / M12 x 1.5 (26mm thread) Tensile Strength 10.9, 60 degree conical fixing, 19mm hexagon bolt head.
Tyre Pressure	See Model
Tyre Size	175/65 R14
Wheel Description	SY262 Black Polish



Assembly 6 - Venus (Twin Axles)	
Torque Setting / Bolt Spec	95Nm / M12 x 1.5 (26mm thread) Tensile Strength 10.9, 60 degree conical fixing, 19mm hexagon bolt head.
Tyre Pressure	See Model
Tyre Size	175/65 R14
Wheel Description	SY934 Gunmetal Grey

Steel (Spare) Wheel	
Torque Setting / Bolt Spec	95Nm / M12 Tensile Strength 10.9



## PREPARING FOR THE ROAD

### AKS STABILISER (where fitted)

This model of stabiliser has 4 special friction pads, which suppress both snaking and pitching. It is essential that the tow ball is kept completely clean as contaminated pads will reduce its effectiveness.

#### Operating instructions

- Using the coupling handle, put the AKS on to the towball. Push the black handle down and check the green indicator button is showing (Fig. 1).
- Press the black stabilising lever down. The AKS is now ready for the road (Fig. 2).

#### Safety indicators

If the green indicator is visible then you know you have correctly coupled your AKS to your towing vehicle (Fig. 3).

#### Wear Indicator

For Coupling mechanism and front/rear friction pads. (Fig. 4)

- Wear of the coupling ball and mechanism can be easily monitored. If the green section is visible (when coupled to your towball) then the front/rear friction pads, coupling ball and mechanism are in order.
- If the red lower section obscures the green section then you need to check these parts immediately.

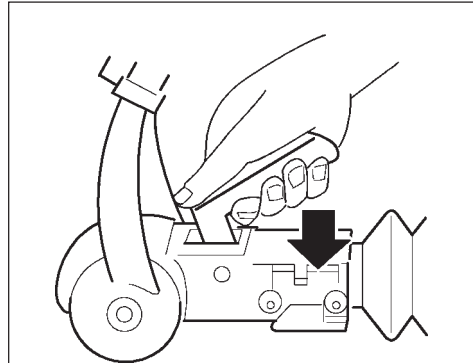

Fig. 1

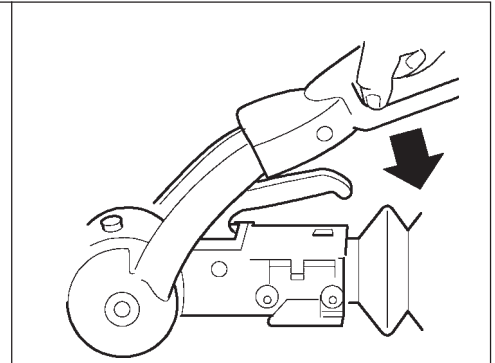

Fig. 2

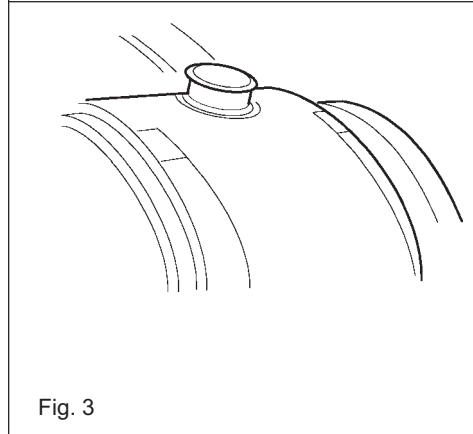

Fig. 3

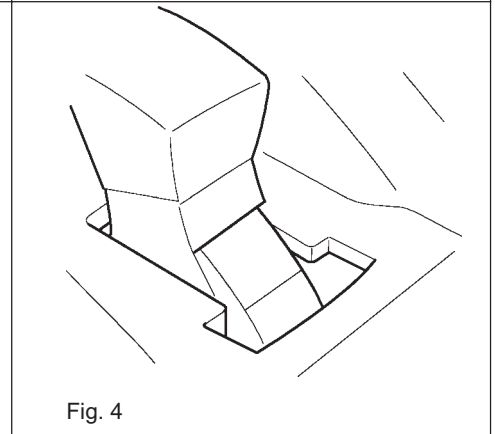

Fig. 4



## OPERATING INSTRUCTIONS FOR AKS 3004 STABILISER

Checking the efficiency of the left/right friction pads

1. Check that the stabiliser is correctly coupled by ensuring the coupling handle is fully down and the red indicator button is in the raised position.
2. Push the stabiliser handle down until resistance is felt (ie. the friction pads are in contact with the ball but not yet under pressure (Fig 6/Item 1).
3. Check the position of the arrowhead on the arm of the stabiliser. If it lines up with the two green lines then the friction pads are still as new (Fig 6/A).
4. If the arrowhead lines up with the two red lines then the friction pads are worn and should be replaced immediately (Fig 6/B).

**Note:** When the stabiliser handle is correctly applied, the arrowhead should line up with the black line marked 2 (Fig 6/C).

**Note:** The friction pads do not require any form of lubrication and should be cleaned with a fine emery paper prior to every journey. It is not necessary to adjust the friction pads.

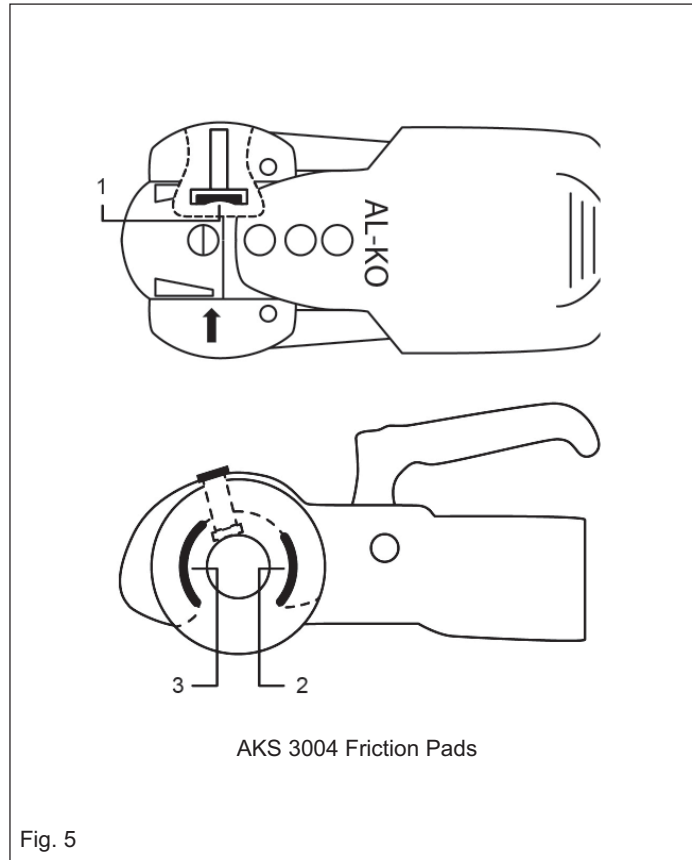



## PREPARING FOR THE ROAD

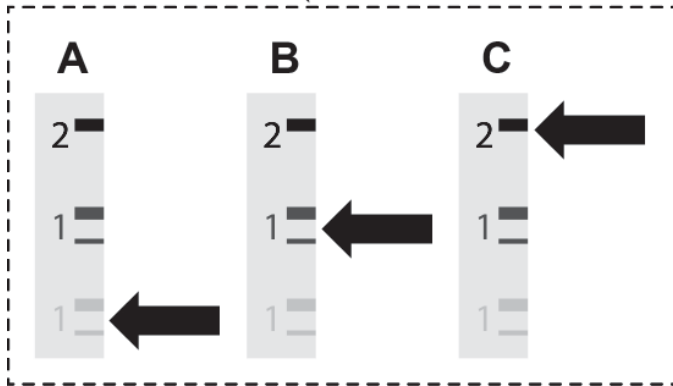
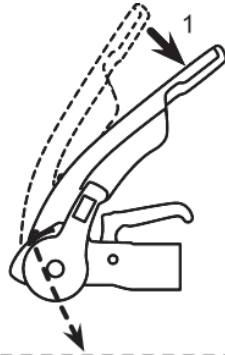

Checking Left/Right Friction Pads

Fig. 6



## Friction Pads Replacement

- Unscrew the 2 screws which are under the soft dock by using the special torx tool (UK version only). (Fig. 7)
- Remove screw from back plate. (Fig. 8)
- Remove friction pads. (Fig. 9)

## Loading Capacity

The AKS can be utilised to tow vehicles up to a gross weight of 3000kg and a maximum nose load of 100kg.

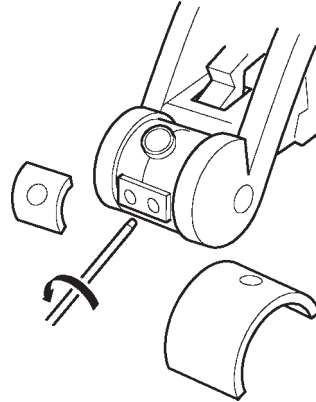

Fig 7

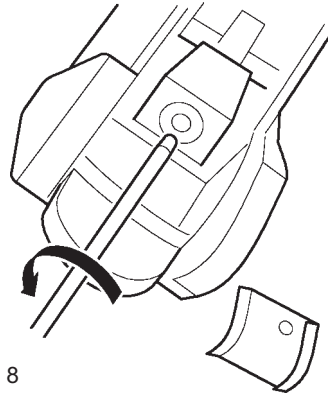

Fig. 8

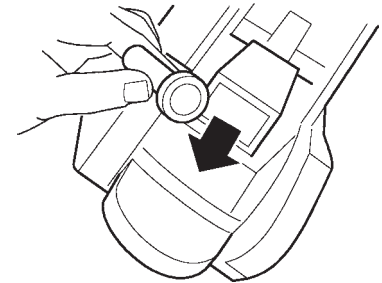

Fig. 9



## PREPARING FOR THE ROAD

---

### AL-KO SECURE WHEEL LOCK

You must register your key, should you fail to do this you will not be able to order a spare key or obtain lost or stolen keys.

*This is how it works:*

- On the Al-Ko Secure registration card you will find an exclusive security number.
- Please register your key by telephoning 0870 7576788 or 0044 1926 818500.
- You will be required to provide the chassis number of the caravan.
- You will need to provide us with a password and supply answers to three security questions.
- Make a note of your password and keep it in a safe place.
- Also keep your registration card safe.
- Take your registration card with you when you are travelling with the caravan.
- Always keep your registration card separate from the lock.

### Safety Information

- Always secure the caravan against movement (chock the wheels, couple to towing vehicle).
- Never leave Secure parts (key, locking bolt, registration card) in the caravan.
- Always remove Al-Ko Secure before moving the caravan.
- After any attempt at theft has been made on a locked Al-Ko Secure, the caravan must be inspected in an Al-Ko Approved Service Workshop.
- Always keep the key in a safe place.
- Keep the lock set and registration card separate from the keys.
- The lock parts and key do not have a registration number, therefore keep the registration card in a safe place.
- Caravans with twin axles have two locks, keep each lock set in a separate place. The sets are not interchangeable!

**Note:** Read the operating instructions and act in accordance with them. Keep the operating instructions for general use. Follow the safety instructions as well as the warning information.





## ASSEMBLY

We recommend the use of a side-lift jack for easier fitting of Al-Ko Secure when used on a tandem axle caravan. (Order No. Al-Ko Jack Set 1389235).

- Align the wheel so that the receiver can be seen in the centre of the rim opening. DO NOT use the rim opening in which the tyre valve is fitted. (Fig. 1)
- Unscrew the plastic cap from the receiver and store in the tool kit box. (When Al-Ko Secure is not in use, always screw the plastic cap in place). (Fig. 2)
- Insert the locking bolt into the rim specific insert. (Fig. 3)
- Insert the locking bolt socket key. (Fig. 4)
- Line up the locking bolts and assembly with the receiver. (Fig. 5)
- Tighten the locking bolt socket using the wheel spanner provided (or torque wrench as shown) to wheel torque. (Fig. 6)
- Remove the locking bolt socket key. (Fig. 7)
- Insert barrel lock. (Fig. 8)
- Hold the lock fast and lock. (Fig. 9)
- The Al-Ko Secure is now fitted. (Fig. 10)

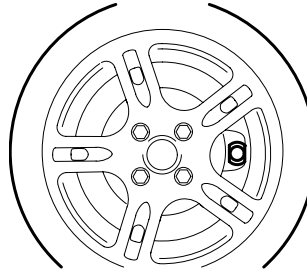

Fig. 1

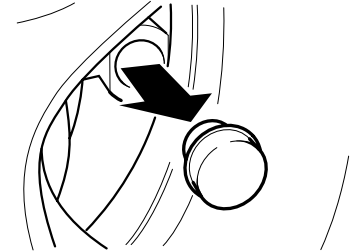

Fig. 2

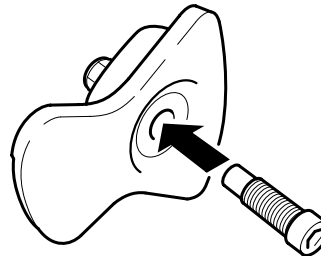

Fig. 3

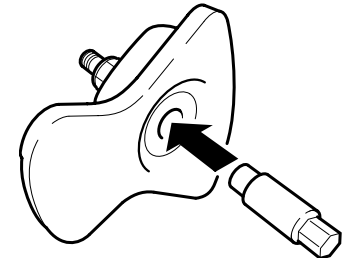

Fig. 4



## PREPARING FOR THE ROAD

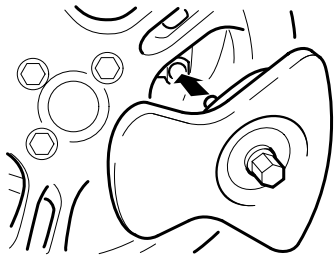

Fig. 5

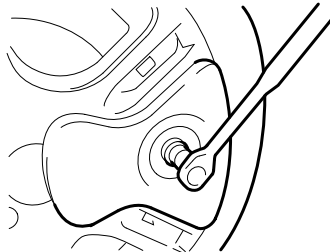

Fig. 6

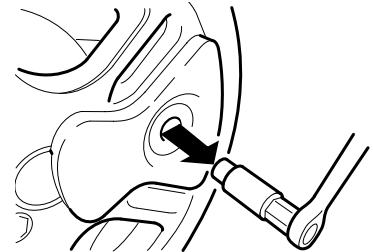

Fig. 7

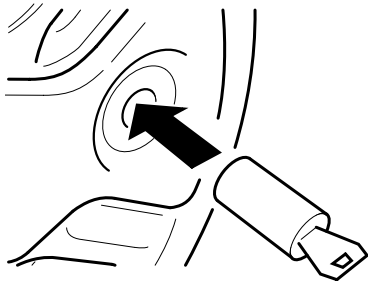

Fig. 8



Fig. 9

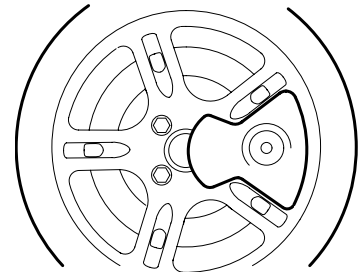

Fig. 10



### TWIN AXLE CARAVANS

Fit the front lock first by aligning the wheel so the receiver can be seen in the centre of the rim opening. Chock front wheel and opposite wheel. Jack the caravan (preferably using the Al-Ko side lift jack) until the rear wheel is clear of the ground. Fit the second lock by aligning the wheel as described previously

**Note: Lost components phone 0044121 5050400.**

In the event of attempted theft report to police and your insurance company.



## PREPARING FOR THE ROAD

### CORRECT ATTACHMENT OF BREAKAWAY CABLES Braked Trailers (up to 3500kg GVW)

Where a designated attachment point is provided on the towbar:

Either:

- a) Pass the cable through the attachment point and clip it back on itself (Fig 1.)

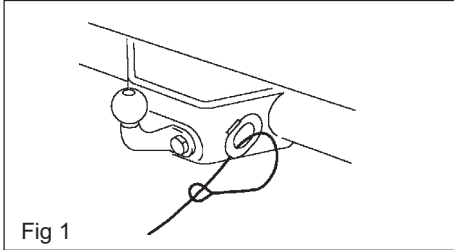

Or:

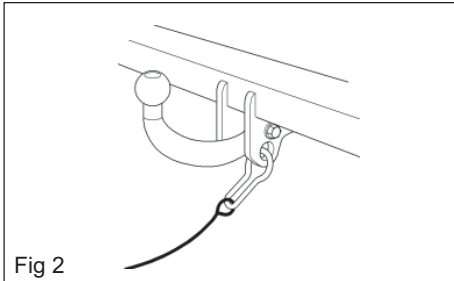

- b) Attach the clip directly to the designated point (Fig. 2). This alternative must be specifically permitted by the trailer manufacturer since the clip may not be sufficiently strong for use in this way.

**Where no designated attachment point has been provided on the towbar:**

**Fixed ball** - Loop the cable around the neck of the towball. If you fit the cable like this, use a single loop only. (See Figs. 3 and 4).

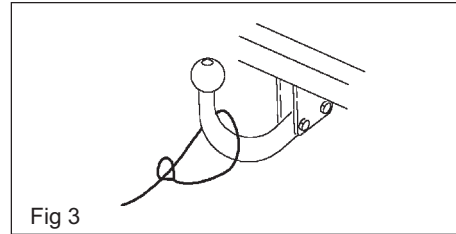

**Detachable ball** - You must seek guidance on procedure from the towbar manufacturer or supplier.

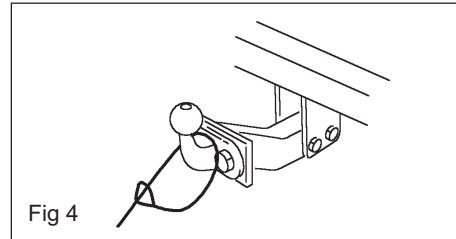

### Other means of attachment:

In some instances it may be possible to attach the cable assembly:

Either:

- a) to a permanent part of the towbar structure, as long as this meets the approval of the towbar manufacturer/supplier,

Or:

- b) to an accessory sold for the specific purpose of breakaway cable attachment.

### Correct procedure for use:

- Regularly check the cable and clip for damage. If in doubt, contact your dealer or your service agent.
- Make sure the cable runs as straight as possible and goes through a cable guide underneath the trailer coupling.
- Determine whether or not the towbar has a designated attachment point (i.e. a part specifically designated by its manufacturer for a breakaway cable).



## When the breakaway cable is attached, check to ensure:

- a) that the cable cannot snag in use on the trailer coupling head, jockey wheel, or any accessory, e.g. a stabiliser, bumper shield, cycle carrier, etc.
- b) that there is sufficient slack in the cable to allow the towing vehicle and trailer to articulate fully without the cable ever becoming taut and applying the brakes.

**NOTE:** For peace of mind you might wish to check the state of the cable by positioning the trailer and towing vehicle at extreme angles before setting off.

- c) that it is not so slack that it can drag on the ground. If left loose, the cable may scrape along the ground and be weakened so that it subsequently fails to do its job. The cable may also be caught on an obstacle when in motion thus engaging the trailer brakes prematurely.

*Having followed this advice, should you feel that a satisfactory coupling arrangement cannot be achieved, consult your trailer or towbar supplier or service agent.*

## This is the Law

UK Law requires that all trailers with brakes built on or after 1st October 1982 (e.g. caravans, horse boxes, flat bed car trailers etc.) are fitted with a safety device to provide protection in the unlikely event of the separation of the main coupling while in motion. A device referred to as a "breakaway cable" fulfills this requirement and when fitted to a trailer its use is mandatory.

Trailer and/or towbar manufacturers should supply advice on the correct use of these cables. In the absence of such information, the following guidance should be noted.

### Purpose of a Breakaway Cable

To apply a trailer's brakes if it becomes separated from its towing vehicle. Having done this, the cable assembly is designed to part, allowing the trailer to come to a halt away from the towing vehicle.

### Construction

Usually a thin steel cable, possibly plastic coated and fitted with a means of attachment for connection to the towing vehicle.

### Operation

In the event of the main coupling of the trailer separating from the towing vehicle, the cable should be able to pull tight, without any hindrance, engaging the trailer's brakes.

**Note:** The breakaway cable should never become taut during normal use.

Please see document for full details.  
[www.thencc.org.uk/downloads/breakawaycable.pdf](http://www.thencc.org.uk/downloads/breakawaycable.pdf)



## PREPARING FOR THE ROAD

### WHEELS

Check wheel nut torques regularly and particularly before a long trip for extra safety.

This service is available at all tyre service depots (inform them of the torque settings)

**Please see chart on page 11 for torque settings.**

- Check wheel/tyres for signs of deterioration or damage.

**WARNING: After a wheel has been refitted, always recheck the torque after 20-30 miles use or 20-30 minutes travelling. Even if properly torqued up, it is occasionally possible for fixings to loosen should the wheel "bed in" on the hub.**

### TYRES

All tyres used on Lunar caravans, when inflated to the pressures recommended, are adequate for speeds up to 130 kph at the maximum specified laden weight of all models.

**Note:** Maximum permitted speed in the U.K. is 60 mph and in the interests of road safety speeds above this are not recommended.

#### Tyre tread

A caravan is subject to the same criteria applied to car tyres, namely; a minimum of 1.6 mm tread pattern depth throughout.

#### Tyre pressures

**Caravan and towing vehicle tyres must be at the pressures recommended for towing or heavy loading.** The pressures can be found in the towing vehicle handbook and under the caravan specification in the service handbook.

**Note:** Pressures should only be checked when the tyres are cold, not after a journey or if the vehicle has been standing in the sun.

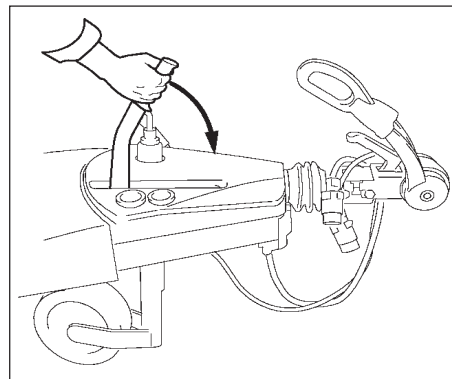

**To release the handbrake, push it forward and down using your body weight.**

**Note:** "Failure to ensure that the caravan handbrake is completely off, can result in overheating of the brakes and failure of the bearings".



## Ground Clearance

Care has to be taken to prevent grounding of the caravan when traversing ramps and ground obstacles. If necessary ground clearance can be increased by removing the jockey wheel when travelling.

## Number Plate

A trailer must carry a rear number plate bearing the number of the towing vehicle and be illuminated at night. The number plate should conform to the same size and colour regulations as for cars. A reflective black and yellow plate may be used on a trailer towed by a vehicle with non-reflective plates and vice-versa.

## Manoeuvring

When pushing or pulling the caravan always use the grab handles correctly, do not snatch them and never push body panels, metal or glass reinforced plastics, as this can cause serious damage to the bodywork or mastic seals.

## Mirrors

The driver of the towing vehicle must have an adequate view of the rear.

If there is no rear view through the caravan it is essential that additional exterior towing mirrors are fitted.

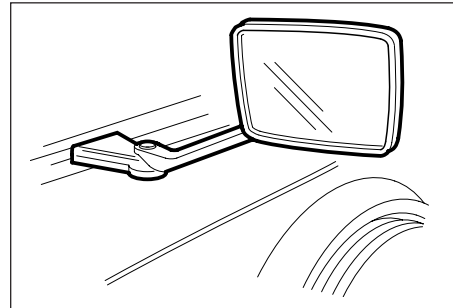

**CAUTION: Any rear view mirror must not project more than 200mm outside:**

- the width of the caravan when being towed.
- the width of the towing vehicle when driven solo.

**Note:** Any rear view mirror fitted shall be 'e' marked and cover the field of view as stipulated by type approved requirements (Regulation 33 of the Road Vehicles [Construction and Use] Regulation 1986).



## PREPARING FOR THE ROAD

### Road lighting

For your information the wiring diagram of the 13 pin connector is shown. These should be checked regularly and if in any doubt a qualified electrician consulted.

### Passengers

Passengers are forbidden to ride in a caravan with the exception of authorized test personnel.

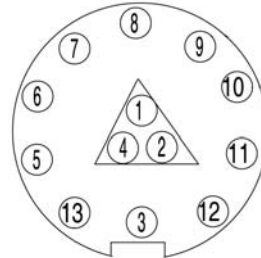

PIN No	COLOUR	DESCRIPTION
1	YELLOW	LEFT IND
2	BLUE	FOG
3	WHITE	NEG FOR ROAD LIGHTS
4	GREEN	RIGHT IND
5	BROWN	RIGHT SIDE LIGHTS
6	RED	STOP
7	BLACK	LEFT SIDE LIGHTS
8	ORANGE	REVERSE
9	BLUE/BROWN	CAR +VE
10	RED/BROWN	FRIDGE +VE
11	GREEN/WHITE	FRIDGE -VE
12	EMPTY	
13	BLUE/WHITE	CAR -VE

13 pin plug wiring diagram



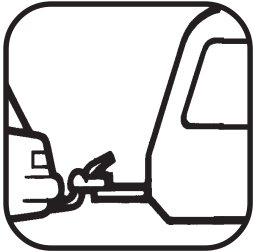

# ON THE ROAD

- Speed Limits ..... 26
- Pulling Off ..... 26
- Caravan Handling ..... 26
- Motorway Driving ..... 26
- Reversing ..... 26
- Changing a Wheel ..... 27
- Jacking Points ..... 27
- Stopping on a Hill ..... 28
- Arrival on Site ..... 28



## ON THE ROAD

### SPEED LIMITS

Normal road towing: 50mph

Motorways (including dual carriageways): 60mph

### PULLING OFF

Let the clutch in smoothly.

Allow more engine speed to produce the power to move the additional weight of the caravan.

Avoid wear and tear on clutch and transmission by taking extra care.

Change gears smoothly.

Try not to jerk the clutch.

### CARAVAN HANDLING

Allow for caravan being wider than car.

Do not bump kerb with caravan wheels.

When passing other vehicles allow more than the normal clearance for driving solo.

Allow longer to get up speed to pass.

Allow for the vehicle being twice its normal length.

Do not suddenly swing out.

Carry out all manoeuvres as smoothly as possible.

Use nearside wing mirror to check caravan has cleared when overtaking.

Never let a 'tail' of traffic build up behind you. Always pull in to let others past.

### MOTORWAY DRIVING

1. Caravans may not be towed in the outside lane of a three or four lane motorway. (Reg. 12(2) of the Motorway Traffic [England and Wales] Regulations 1982).
2. Reduce Speed:
  - i) In high or cross winds.
  - ii) Downhill.
  - iii) In poor visibility
3. High sided vehicles cause air buffeting so extra care must be taken when passing or being passed. As much space as possible should be given.

### Reversing

Proficiency at reversing can only be achieved with practice and should be first attempted in a large open area.

Your caravan is fitted with an automatic reversing mechanism which allows you to reverse without the need to make any adjustments. **After reversing, the caravan should be drawn forward at least 1 metre to restore the brake shoes to their normal position before applying the hand brake.**

**Note: Reversing uphill will be difficult if either wheel brake or brake linkage is overadjusted. You need to ensure that the brakes have been disengaged before reversing uphill.**

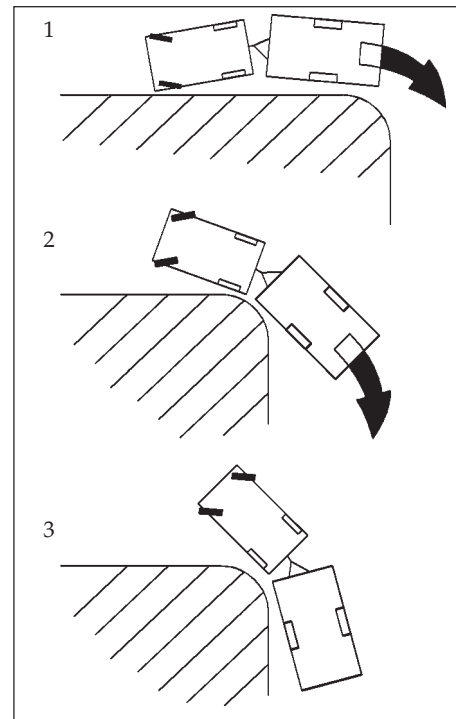

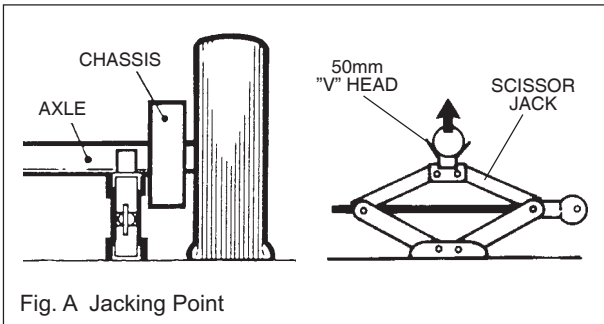

Fig. A Jacking Point

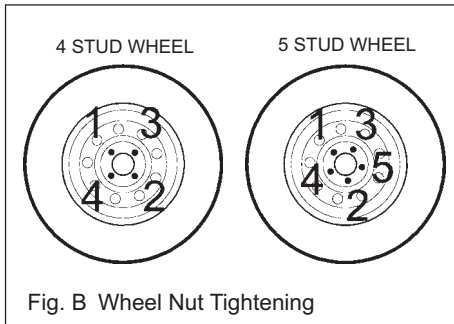

Fig. B Wheel Nut Tightening

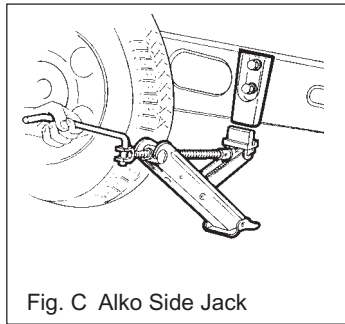

Fig. C Alko Side Jack

## CHANGING A WHEEL

1. Leave caravan hitched to towing vehicle and ensure handbrake is applied.
2. Lower corner steadies (as safety measure) on the side that the wheel is being changed to stabilise the caravan.
3. Use wheel brace to slacken off wheel nuts on the wheel to be changed.
4. Position jack under the axle at the appropriate jacking point (see fig. A).
5. Jack up the caravan until the wheel for removal is just off the ground.
6. Remove the wheel bolts, wheel trims and remove the wheel.
7. Fit spare wheel and reverse the above procedure.

See **Preparing for the Road Page 11** for torque settings.

### Note: When changing a wheel ensure:

- a) that the correct wheel fixings are used.
- b) that there are clean, dry mating surfaces and clean, dry bolt/nut area.

**NB: Special nuts are supplied with alloy wheels and these can be used where a steel wheel is used as a temporary spare.**

### IMPORTANT

When a wheel has been removed and replaced the torque of the wheel nuts should be re-checked after approximately 15 miles of running.

## JACKING POINTS

It is recommended that the jack is located in the correct position i.e. on the axle tube inside the chassis member (Fig. A). The reinforced axle mounting plate can be used as an alternative but the chassis-member itself **MUST NEVER** be used as a jacking point.

### Alko Side Jack

The Alko chassis is provided with the facility to fit an Alko side jack which can be fitted as an optional extra (Fig. C).



### STOPPING ON A HILL

Pulling off again can sometimes present a problem. The easy solution is:

- (i) Carry a good sized wedge shaped piece of wood with a rope or light chain attached.
- (ii) Attach the other end of the rope to the nearside rear grab handle.
- (iii) Place the wood behind the nearside caravan wheel.
- (iv) Carefully reverse the car slightly back down the hill, the caravan will stop against the wedge and turn.
- (v) Drive forward since this attempt to move up the hill will now not involve pulling the full weight of the caravan until the car has gained some traction.

### Ramps

Take care to prevent fouling when traversing ramps or other ground obstacles.

### ARRIVAL ON SITE

**Note: Check and observe site regulations.**

#### 1. Selecting a pitch.

Do not pitch in such a position that your outfit will obstruct others coming in.

Try to choose an area which is dry, reasonably level and preferably with a hard base.

If you have no alternative but to pitch on a slope ensure that, for when you leave, you are facing down the slope.

It is good practice to chock the wheels of the caravan when parked on a slope even though the caravan brakes are applied.

#### 2. Siting/Unhitching

When you arrive at your site and have been allotted a pitch:

Manoeuvre your caravan onto your pitch (if you have reversed read the notes on page 20), apply the handbrake, remove the brake safety cable, unplug the 13-pin plug and store these in the sockets provided on the 'A' frame cover.

Unclamp and lower the jockey wheel to the ground. Re-clamp the jockey wheel after first unscrewing slightly.

Free the coupling by winding up the coupling head until it is clear of the 50mm ball. Replace the tow ball cover and then park your car.

#### 3. Levelling the caravan

Levelling must be carried out in both directions in order for the refrigerator and other equipment to function correctly.

The positioning of the jockey wheel can be used to help level the caravan.

Lower the corner steadies until they are in firm contact with the ground. DO NOT use the steadies as a jack they are only a means of stabilising the caravan.

Levelling pads or boards should be used under the steadies where the ground is soft or uneven. Stepped levelling boards can easily be constructed (Fig. D).

In extreme cases where it is necessary to raise a wheel off the ground for levelling purposes, further adequate support should be applied so that the steadies do not take any undue strain.

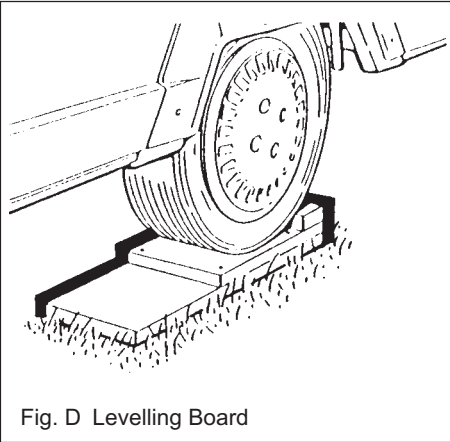

Fig. D Levelling Board

### Exterior Door

To prevent distortion of the body, the caravan must be always correctly sited and levelled. Failure to site the caravan correctly may prevent the exterior door from closing properly.

**Attention:** Always disconnect the electrical connector between the towing vehicle and the caravan before connecting an LV supply to the caravan and before charging the caravan battery by any other means.





**FIRE  
&  
SAFETY**

- In Case of Fire ..... 32
- Smoke Alarm ..... 32
- Carbon Monoxide Alarm ..... 33
- Fire Extinguisher ..... 33
- Children ..... 33
- Ventilation ..... 33
- Security ..... 34
- Theft ..... 34
- Chassis Number ..... 34
- Additional Security ..... 34
- Datachip Security Card ..... 34



## FIRE & SAFETY

### FIRE ACTION

1. **GET EVERYONE OUT**
2. **TURN OFF GAS VALVE**
3. **RAISE THE ALARM AND CALL THE FIRE BRIGADE**
4. **DISCONNECT THE MAINS ELECTRICITY SUPPLY**
5. **TACKLE THE FIRE IF SAFE TO DO SO**
6. **MAKE YOURSELF FAMILIAR WITH THE INSTRUCTIONS ON YOUR FIRE EXTINGUISHER AND THE FIRE PRECAUTION ARRANGEMENTS ON THE SITE**
7. **CHECK FIRE EXTINGUISHERS REGULARLY**
8. **CHECK GAS PIPING AND MAINS ELECTRIC WIRING ANNUALLY**

**If you suspect a gas leak - never use a naked flame to search - always use soapy liquid or - better still - call your caravan dealer.**

### Important

With any extinguisher, never use it on a pan of fat - this is very dangerous - always use a fire blanket.

To tackle a pan fire: First of all, if possible try to turn off the gas. Make sure you are aware of the position of the gas isolating taps - usually placed in the sink unit cupboard.

Never throw a flaming pan outside, keep your hands away from the flames and smother the flame.

Try to remain calm.

Do not throw the blanket on the fire but place over the pan paying particular attention to the handle.

### Fire Precautions

Make sure you are aware of the operation and location of escape windows and doors.

It is advisable to carry a fire extinguisher (a dry powder is recommended) positioned as near to the exterior door as possible.

A fire blanket approved to BS 6575 is also advisable positioned as near to the cooking area as possible.

Check the fire regulations on arrival at sites. Do not leave pans on the stove unattended. Do not leave matches within easy reach of small children.

Never leave small children alone in the caravan.

Do not smoke in bed.

Do not block up ventilators.

### SMOKE ALARM

The Code of Practice requires that a smoke alarm is fitted in your caravan. Every new manufactured caravan has a smoke alarm fitted as standard equipment.

### Connecting the battery

Your alarm requires one 9 volt battery to power the smoke detector portion of the unit. Under normal use, the battery powering the smoke detector should last approximately one year. See label inside smoke alarm lid for suitable batteries.

With a pencil, write the date of battery installation on the inside of the cover to remind you when to replace the battery.

Lift battery from battery holder and snap battery connectors to battery. They fit together only one way.

Gently push battery into battery holder.

To close the cover match up snap-in hinges and gently press together until base and cover snap together.

### IMPORTANT:

**When the battery is first connected the alarm may sound for 2–3 seconds.**

**THIS IS NORMAL.**

**It means the battery is connected correctly.**

### Replacing the battery

Test the alarm for correct operation using the test button whenever the battery is replaced.

When battery power is low and replacement is necessary, the alarm will 'beep' about once per minute for at least 30 days. The battery





must then be replaced. Replace battery if the alarm does not sound when the test button is pressed. For maximum reliability, replace battery at least once a year.

## Testing the Smoke Alarm

It is recommended that you test the smoke alarm once a week to be sure the unit is working. It will also help you and your family to become familiar with the sound of the alarm.

When you press the test button it simulates the effect of smoke during a real fire. So, there is no need to test the alarm with smoke.

Press and hold the test button until the alarm sounds (it may take up to 10 seconds). The alarm will stop sounding shortly after the button is released.

## Cleaning the Smoke Alarm

Clean the smoke alarm regularly. Use a soft bristle brush or the brush attachment of your vacuum cleaner to remove dust from the sides and cover slots where the smoke enters. Keep cover closed while cleaning. Do not vacuum or brush inside the smoke alarm. To clean the cover, remove it completely and use only mild soap and water. Dry cover thoroughly before replacing it.

### **WARNING: Do not paint the Smoke Alarm.**

Other than the maintenance and cleaning described above, no other customer servicing of this product is required.

## CARBON MONOXIDE ALARM

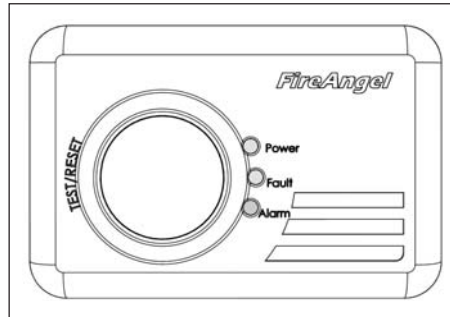

Your carbon monoxide alarm is located on the underside of the offside or nearside locker. Under normal operating conditions the power pack will last for the lifetime of the product (7 years). Batteries for this product are non replaceable.

It is recommended that the alarm is tested weekly by pressing the test/reset button.

### LED Indicators

**Power.** In normal operation the LED will regularly flash green.

**Fault.** If a fault is found in the sensor and circuitry or the power pack becomes low then the detector will emit a single chirp once per minute and the fault LED will flash yellow once per minute for 30 days.

**Alarm.** When sufficient carbon monoxide is detected a loud audible signal will be emitted and the alarm LED will flash red once every second. When alarm is tested the LED will illuminate red.

## FIRE EXTINGUISHER

It is recommended that a 1kg (2lb) minimum capacity dry powder fire extinguisher be carried inside your caravan at all times. (NCC recommend types marked 5A34B).

When using a dry powder extinguisher it is suggested that the caravan be evacuated until the powder has settled, to avoid inhalation.

A fat pan fire should not have a fire extinguisher aimed at it. It should be smothered with a fire blanket.

### Children

Do not leave children alone in the caravan in any event. Keep potentially dangerous items out of reach, as at home e.g. matches, drugs etc.



## FIRE & SAFETY

---

### Bunks

Where fitted, the foldaway bunk has been tested to 70kg (11 stones) and has a recommended limit of 57kgs (9 stones). Safety features are included but care should always be taken, particularly if the child is under 3 years of age. Bunks are not suitable for children under 6 years old without supervision.

Solid (fixed) bunks have a recommended limit of 75kg (12 stones).

### Ventilation

All caravans comply with British Standards EN1645. The ventilation points on your caravan are fixed points of ventilation which are stated by the British Standards.

Ventilation is provided at floor and ceiling level and care should be taken to ensure these remain clear of debris by regular cleaning.

### **Under no circumstances must these vents be blocked or obstructed.**

It is advised that fixed ventilation points are checked and cleaned (if necessary) on a regular basis.

Additional night time ventilation is obtained by releasing the window catches and placing them in the second groove on the frame catch.

You must maintain adequate spacing of combustible materials from sources of heat (eg heater)

Do not use independent gas appliances inside the caravan.

We advise that the user instructions for the fitted appliances are studied in addition to the information in this handbook.

### **Petrol/Diesel Fumes**

The fitting of a tail pipe to your car exhaust will reduce the possibility of fumes entering your caravan through the front fixed ventilation points.

## SECURITY

### **Caravan theft**

The theft of a caravan can occur in the most unlikely circumstances; from a motorway service area, even from an owner's driveway.

Secure all windows and doors when your caravan is unoccupied even if only for a short length of time.

**Please see General Data for CRIS information.**

### **Additional security**

Consider fitting any device which might deter or prevent intrusion by thieves.

A hitch lock cover helps to prevent towing of the caravan.

A wheel lock prevents towing of the caravan and removal of the wheel.

Customers are advised to identify their caravan with a method for subsequent identification if other forms of identification have been altered or removed.

### **Datachip Security Card**

Each model has a datachip security card concealed within the body of the caravan, showing the VIN.



# SERVICES

Water .....	36
Gas .....	42
Electricity .....	46



## SERVICES

### STANDARD WATER SYSTEM

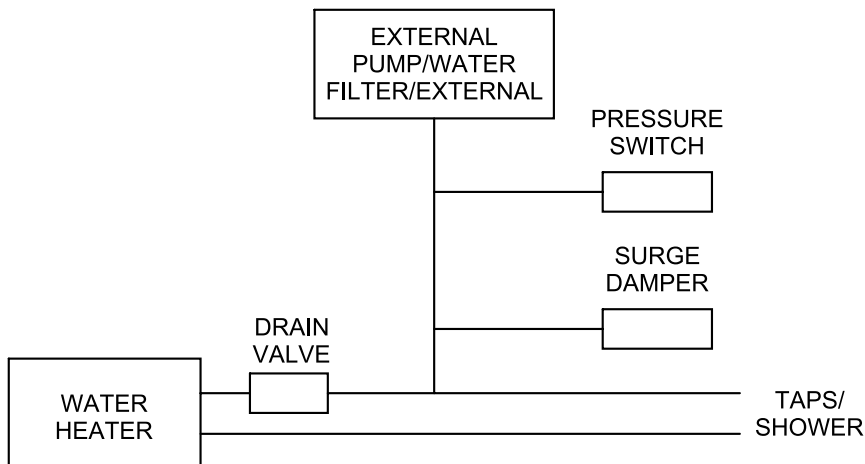

### Surge Damper

The surge damper prevents water hammer and also reduces switch hunting on and off.

The surge damper is a completely sealed unit and requires no servicing, however, as with water systems, the complete system should be drained in the winter.

### The Filter

The filter attaches directly to the pump and incorporates a non- return valve designed to prevent dirt and grit from entering the pump valves as this will cause pump failure. The filter is fitted during installation to protect the pump.

### Pressure Switch

The pressure switch is operated by the opening and closing of the taps/shower. When a tap is opened the pressure in the system is altered which activates the pressure switch supplying power to the selected pump.



## Maintenance

Poor pump performance may be an indication that the filter has become blocked by debris. The filter is easily removed for inspection and cleaning:

- Remove circlip and unscrew filter from pump.
- Pull two halves of filter apart to expose the strainer mesh.
- Remove any debris and replace strainer mesh in position.
- Ensure the rubber seal is correctly seated in the groove on the outlet side of the strainer before pushing the two halves firmly together.
- Attach to the pump and replace the circlip.
- See arrow on pump housing for flow direction.

## Care of your Submersible Pump

Care should be taken to ensure that the pump is not allowed to run dry for appreciable periods. Whilst the design will allow some dry running, such as when the tank requires refilling, the pump life will be appreciably lengthened if care is taken to minimise dry running.

## Aquaflow Caravan Filler

There is a special filler fitted for use with the Submersible Pump which not only provides a recessed, locking filler cap for water input, but also a polarised power take-off point complete with input plug. This is part of the original equipment for Delta models only.

### The Water System for Delta Models

A submersible pump is used for pumping water from an external container into the inboard tank of the caravan.

### To Operate The System

First ensure that the drain tap on the inboard tank is closed. Place the pump inside your filled container. Place the hose into the filler cap on the side of the caravan. Plug in the 12 volt plug into the socket on the filler cap. When the water container is empty unplug the 12 volt -do not allow the pump to run dry.

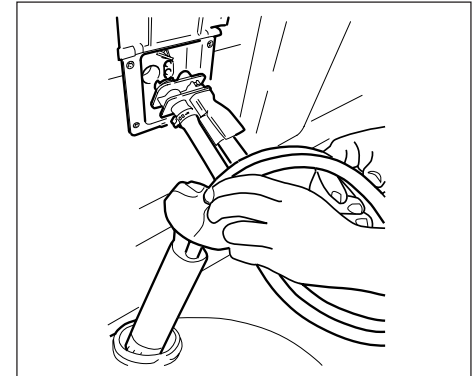

## WATER PUMP

The separate plug-in pump assembly consists of a Crystal Maxi pump, hose and plug. The plug provides connection of both water supply to the caravan and 12V dc electric power to the pump. A dust cover is fitted to the connecting dual hose to prevent contaminants falling into the water container.

The Crystal Maxi pump is a completely sealed unit designed for intermittent use. It is NOT self-priming and therefore to ensure proper performance, the pump MUST ALWAYS be fully submersed in water BEFORE plugging into the wall socket.



## SERVICES

### Initial connection to fresh water supply

1. Fill the fresh water container and place it alongside the wall socket located in the offside external wall of the caravan.
2. Ensure the pump isolator switch at the control panel inside the caravan is switched off.
3. Open the 'hot' kitchen tap. Ensure all other taps are closed.
4. Place the pump into the water container outside the caravan, taking care to ensure the pump reaches the bottom of the container.
5. Lift the lid of the wall socket and fit the pump assembly plug into the socket. Ensure it is pressed in fully.
6. Adjust the dust cover to fit over the opening in the water container to keep contaminants out.
7. Switch on the pump isolator switch at the control panel inside the caravan.
8. Wait until water flows freely from the 'hot' kitchen tap. Allow to flow for a few more seconds to ensure release of any trapped air in the water system, then turn the tap off.

Repeat the same procedure with the 'cold' kitchen tap.

If the system has been drained, the above procedure **MUST** be repeated **EVERY** time the water container is filled.

Switch on the pump isolator at the control panel.

Once it has been properly connected, and a tap is turned on, the pump is activated automatically by a pressure switch.

### Fault Finding

1. *Pump runs very noisy but does not pump water.* Likely to occur after water container has been refilled. Pump is air locked. *Cure:* unplug from socket allowing pump to flood, and reconnect by plugging in again. The correct sequence when refilling the container is to unplug, replace pump in container, then reconnect.
2. *Pump fails to deliver water.* The most likely cause will be air in the system. To remedy this, switch off the pump and shake the pump assembly in the water. Then switch on again. Alternatively, make sure the assembly is positioned fully into the housing.
3. *Pump does not run at all.* If not due to blown fuse or faulty connections, then most likely cause is excessive continuous running. *Cure:* replace pump.

**Never allow the pump to run dry.**

**Never allow the pump to run continuously for more than 15 minutes.**

**Note:** When refilling the water container, the pump assembly may be left plugged into the wall socket so that the pump can be kept off the ground by inserting the hose into the groove on the underside of the plug. But, the pump assembly **MUST** be unplugged **BEFORE** replacing the pump into the refilled water container.

### STERILISING

When cleaning the water system at the start or the end of the season, it is advisable to use the sterilising fluid, e.g. Milton 2, Chempro SDP or similar. It is recommended that for this operation you use any empty filter body as the fluid reduces the effectiveness of a new filter.

Flush the system thoroughly to remove the effective fluid traces.

After sterilising the system at the start of the season it is recommended that a new filter cartridge is fitted.

### NOTES

- Never allow the pump to run dry. Always ensure that the pump is submerged in the water or the life of the pump will be reduced.
- Before winter storage, the water system must be completely drained.
- Clean the water system at the start and



end of the season with sterilising fluid (see notes under sterilising).

## Water System Winterisation

Caravans may be in use all year round, but when not in use, even for short periods, this procedure should be followed. One night of freezing temperatures is all that is required for expensive permanent damage to water system components.

- a. The whole system must be drained.
- b. Open kitchen taps. Lever taps should be lifted in central position, leave taps open permanently after system drain down.
- c. Open bathroom and shower taps (including shower on/off control rose) and leave open permanently after system drain down.
- d. Shake the shower head to remove the water held there and in the hose. At this point it is recommended to remove the shower head from the hose. Even the smallest amount of frozen water can result in the shower head cracking.
- e. Remove cold water drain plug (if fitted), normally located under the caravan near to the water inlet socket.
- f. If possible remove any remaining water from system plumbing at water inlet sockets and in between in-line pressure switch plumbing.

- g. Disconnect cartridge or in-line filters from plumbing.
- h. Submersible pumps should be shaken out and stored in a dry place.
- i. Drain the external shower bridge connection (including models without external shower) on the Ultraflow housing by inserting the shower connection or open the valve by means of a tool to push on the black rubber pad of the valve.

## Cleaning the Water System and Portable Water Tanks

The water systems, and in particular storage tanks, in caravans are susceptible to contamination by bacteria if care is not taken with their use and cleaning. The symptoms caused by bacterial contamination are not purely limited to gastro-intestinal diseases, but may also manifest themselves as ear, nose, throat, eye or skin infections. It is therefore important that you carry out the following procedure prior to using the caravan each time, even if you boil or filter all water you use for drinking.

## Water Containers

1. All water remaining in the container should be disposed of so that the container is empty.
2. The outside of the container should be thoroughly cleansed and washed down to

remove any dirt, dust or other contaminants. Water at a suitably hot temperature containing an appropriate detergent is recommended for this purpose.

3. Water should be placed in the container, swirled around, then emptied out.
4. The container should then be totally filled with water containing an appropriate disinfectant/sterilant solution and allowed to stand for the recommended contact time (e.g. Milton for 15 minutes).
5. The solution should be emptied from the container.
6. The opening of the container should be cleaned thoroughly with an appropriate pre-prepared wipe impregnated with a disinfectant/sterilant.
7. The container should be inverted whilst stored overnight (if possible).
8. The container must be filled with mains water only and mains water only should be used for the above cleaning procedure.
9. On no account should garden hoses be used to fill water tanks.

## Water Systems

1. Drain down the system. (Open all taps to allow air in, enabling the system to drain quickly.)



## SERVICES

---

2. Remove any water filters fitted, and replace with a short length of hose or empty filter cartridge (this will ensure the filter is not affected by the disinfectant/sterilant solution).
3. Fill the system by using the pump with a disinfectant/sterilant solution. (Check that the solution at full strength appears at all taps/showers). Allow to stand for the recommended period of time.
4. Drain the system down using the water systems internal flip switch located under the front off-side bed.
5. Thoroughly clean the outside of all taps/connectors with a cloth soaked in the disinfectant/sterilant.
6. Flush the system through with clean drinking water until no traces of disinfectant/sterilant can be detected at any tap.
7. Replace the filter.

Suitable sterilising chemicals are available from your caravan dealer, accessory shop, chemists or home-brew shops. It is not, however, recommended to use bleach or sodium metabisulphite.

### Setting Up the Water System

1. Replace/close all drain valves.
2. Replace shower heads and tap spouts.
3. Close all taps.
4. Refit old filters:
  - a. Check all plumbing connections.
  - b. It is recommended at this point to sterilise your water container and flush the system through with sterilising fluid.

#### **Note:**

**Frost damage cannot be claimed under warranty.**





## PRESSURE SWITCH

### Operation

The pressure switch detects the opening or closing of any tap in the system and switches the pump on or off accordingly. It is located near the water heater.

### To prime if fitted with a submersible pump:

1. Trapped air in the submersible pump will not allow the pump to prime. Air can be released by gently shaking the pump under water while the pump is in the water tank but is switched off.
2. If an external submersible pump is used, place the pump in the water before connecting to the side of the van.

At normal flow rates the pump should operate continuously — but at low rates the pressure switch will cycle on and off to maintain back pressure in the pipework.

### Adjusting the pressure switch:

If the battery voltage is not constant, cycling may occur. This can be minimised by adjusting the switch's diaphragm sensitivity as follows:

1. With the system properly primed, close all taps and showers.

2. Leave the power supply turned on.
3. Tighten the adjusting screw (clockwise). The pump should now be running.
4. Partly open one cold tap to allow water to flow at about 1 pint per 15 seconds.
5. Now slowly loosen the adjusting screw until the switch starts to click. The switch will then be properly adjusted.

### Helpful Hints

- a) If the pump will not run:
  - Pump could be faulty or a wire disconnected.
  - Check that the pump isolating switch is turned on.
- b) If the pump cycles on/off:
  - Battery voltage may be too low (at or below 10.5 Volts). Adjust switch (see text) and/or recharge battery.
  - Check for air or water leaks in taps and piping. Re-adjust pressure switch.
  - Non-return valve may be held open by grit.

Study the exploded drawing and remove the three assembly screws to gain access to the non-return valve.

- c) If a pump motor runs steadily and will not stop:
  - Battery voltage may be too low (at or below 10.5 volts)

- Check all connections in the pipe-work.
- Remove the adjusting screw, if motor still runs, pump is probably air locked. Turn off the isolator switch and reprime the pump (see text).

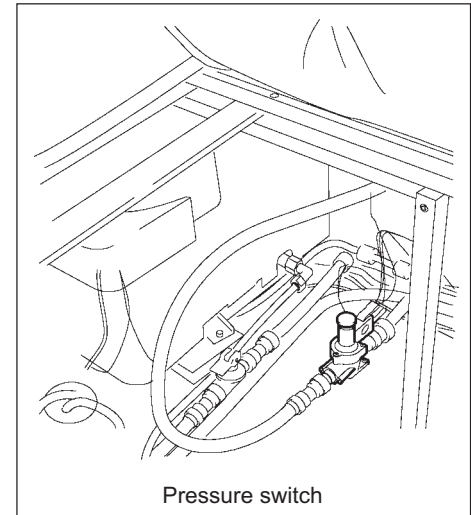



## SERVICES

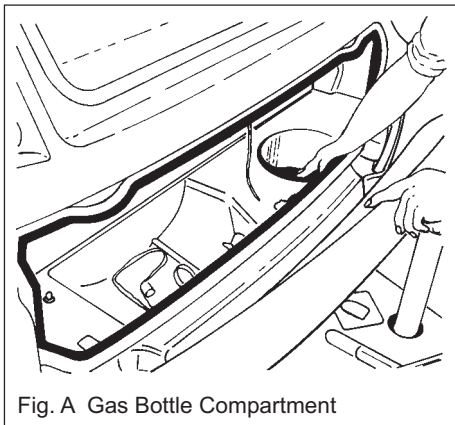

Fig. A Gas Bottle Compartment

### GAS

#### GENERAL INFORMATION

##### Gas Bottles

Bottled Liquefied Petroleum Gas (LPG) is the most convenient portable source of fuel for your caravan.

Make sure that heating and cooking appliances and the gas cylinders are switched off before you move the caravan.

Regularly check flexible gas hose, joints and connections for tightness. Finally make sure that each gas appliance is working efficiently to the recommendations of the appliance manufacturers.

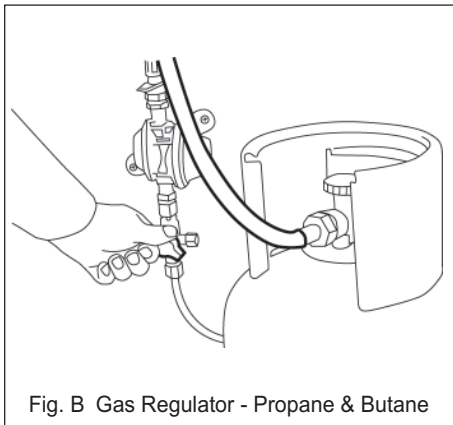

Fig. B Gas Regulator - Propane & Butane

In all cases the cylinder contents are in liquid form under pressure from the gas above it, and the pressure is only dependent on the type of L.P.G. and its temperature.

When gas is supplied the pressure in the cylinder is slightly reduced and liquid "boils" off to restore the balance. This action cools the liquid and the cylinder, and condensation or even frost may sometimes be observed on the outside of the cylinder. The cylinder, when in use, is always cooler than the surrounding air so allow plenty of circulation in cool weather and do not cover the cylinder with a "cozy" in the winter.

Butane works satisfactorily at temperatures down to 2° C. Propane should be used for temperatures below this, therefore for all year round caravanners, Propane is of greater use.

There are different sizes of bottles available and it is better to consult your dealer for advice. Gas cannot be supplied from the bottle without an approved regulator.

Hoses connected from regulator to the caravan supply should be made from Neoprene and comply with EN1949. Hoses have a limited life and should be inspected regularly.

The gas cylinders have a recess in the gas bottle compartment into which the cylinders should be restrained by means of the straps provided.

If cylinders are used outwith this compartment you must ensure 1) they are adequately supported b) ventilation is not blocked c) damage will not be caused to fixtures and fittings.

Never use a gas cylinder on its side - always stand cylinders upright - keep them in the gas locker provided (Fig. A).

Please note that the Gas Locker Box is not a watertight compartment.



If you should suspect a gas leak turn off the gas at the bottle and ventilate the caravan by opening the door and windows. Do not operate anything electrical and remove everyone from the caravan until the gas has dispersed. It is part of your annual service to inspect all gas pipes and appliances.

## Changing a Gas Cylinder

Before commencing to change a gas cylinder ensure that the valve on the cylinder is turned fully off. Turn off all gas operated appliances.

Remove the gas hose from gas cylinder.

Before refitting a gas cylinder, ensure that all gas operated appliances are turned off – particularly after winterisation. Ensure all connections are secure.

## The regulator

Your caravan is fitted with a regulator (capacity 1.5kg/hr) as standard equipment (Fig. B). This is located in front gas bottle locker. The gas regulator has a working pressure of 30mbar and is suitable for both propane and butane liquefied petroleum gas.

**Note:** Regulator valves should always be in the 'OFF' position when towing.

The 30mbar bulkhead mounted regulator fitted to the caravan requires a 'pigtail' connector for use with UK LPG cylinders, see your dealer for details.

To effect a safe connection with a European cylinder, you will need to obtain a 'pigtail' connector appropriate to the cylinders available in the country you are visiting.

**DO NOT** use the conventional cylinder-mounted 28mbar/37mbar regulators as the gas pressure is not compatible with the appliances installed in your new caravan/motorhome.

## Hoses

Inspect flexible hose(s) regularly for deterioration and renew, as necessary, with approved type. In any case not later than the expiration date marked on the hose. LPG hoses should be routinely replaced at intervals not exceeding 5 years or as recommended in manufacturers' instructions. Any hoses that show signs of splitting, wear or damage should be replaced irrespective of age.

If the gas supply hose is to be left disconnected for an extended period ensure the open end is protected against the entry of dirt or insects.

## TYPES OF GAS

### Butane

Butane is supplied in the U.K. in blue bottles.

Butane is suitable for use at temperatures down to 2°C, but will not work below that temperature.

### Propane

Propane is supplied in red bottles which have a left-hand threaded connector.

Propane will work at temperatures as low as -40°C and is therefore suitable for winter caravanning.

Make sure that heating and cooking appliances are turned off, and also the regulator at the gas cylinders before travelling.

**Never allow modification of LPG systems and appliances except by qualified persons.**



## SERVICES

### GAS SAFETY ADVICE

#### Facts about LPG

LPG is not poisonous.

Bi-products are harmless.

There is danger if all air and oxygen were excluded. (Ventilation holes must be kept clear at all times).

LPG has been given a smell by the manufacturers in order to identify leaks.

#### Awning Spaces LPG Appliance Exhaust

There is no danger of pollution of an enclosed awning space by the LPG exhaust from a refrigerator venting into it.

Space heaters may produce sufficient exhaust to pollute the awning space, if it is totally enclosed, from a general comfort, smell and hygiene point of view. In the extreme case there could be a build up of carbon dioxide to a dangerous level.

Caravan owners are advised to allow some fresh air circulation in the awning space when such appliances are in use.

### PRECAUTIONS

- a) Never look for a leak with a match. Always use a soap solution or its equivalent when testing connections. Do not operate any electrical apparatus whatsoever, especially light switches. If the leak is not obvious, the caravan should be evacuated and qualified personnel consulted.
- b) Avoid naked lights when connecting or changing a cylinder.
- c) Check the flexible hose frequently.
- d) The gas is heavier than air and therefore sinks to the lowest point.
- e) Keep bottle gas containers outside (and protected against frost). If they must be kept inside make sure they are well away from heat.

#### Ventilation

Fresh air circulation should be allowed below the caravan when appliances are in use and when flues terminate below the floor to allow free evacuation of the products of combustion. At least three sides of the underfloor space should always be kept open and unobstructed especially by snow. Do not make any additional openings in the floor.

Fixed ventilation openings are sited under gas appliances in various locations in your tourer.

#### WARNING

**Under no circumstances should fixed ventilation openings or gas appliance flues be obstructed in any manner as this could lead to a build up of dangerous carbon monoxide. Gas drop holes under appliances should also be kept clear at all times. Grilles and flues should be kept clean and free from dust.**

All ventilation complies with BS EN1645 and vents should not be obstructed in any manner as this could lead to insufficient fresh air. In this case the confined atmosphere becomes depleted of oxygen which leads to the formation of the highly poisonous gas 'carbon monoxide'. Carbon Monoxide is odourless, colourless and tasteless and will rapidly cause unconsciousness and death with little or no warning prior to collapse. THERE IS NO DANGER WHEN ADEQUATE VENTILATION IS PROVIDED.



## Roof-mounted Flue installations

All flue installations should be inspected once a year throughout their length for corrosion. Flues should be replaced if any sign of perforation is found. Ensure that the replacement is of an approved type.

## CONNECTION

Ensure that the gas regulator is correctly connected to the gas cylinder in gas bottle compartment and that the hose is tight. Before turning on the gas supply, ensure that all gas operated equipment in the caravan is turned off.

## Safety Hints

It is advisable to TURN OFF THE MAIN VALVE on the gas container when the caravan is left unattended for a period or is on tow, except where continuous operation appliances (such as a refrigerator) are in use. AVOID NAKED LIGHTS when connecting or changing a container. Make sure all appliances are turned off.

## Space Heating Appliances

Space heating appliances are to be completely extinguished before the caravan is moved and are not to be used when the caravan is in motion. Portable heaters should not be used.

## Manifold Locations

Heater and Water Heater manifold located underneath front O/S bed towards bulkhead.

Cooker and Fridge manifold located within compartment below cooker.

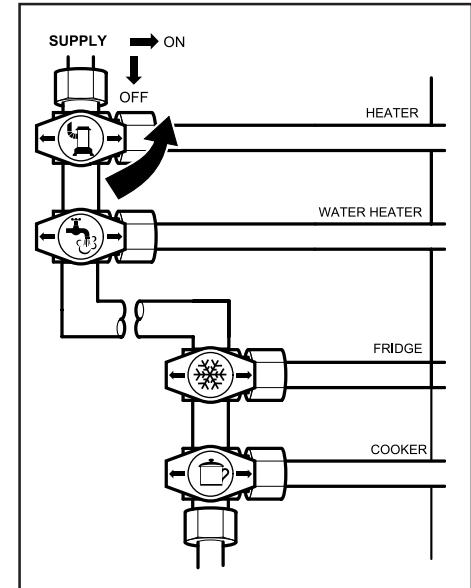



## SERVICES

### MAINS ELECTRICS

#### 230V Mains Electric Equipment Usage

For your convenience and pleasure this touring caravan is fitted with a 230V mains electrical installation.

**Please note:** It is possible that all of the 230V mains electrical equipment may not be able to be operated simultaneously. A typical UK caravan park mains hook up point provides a maximum output of 16 amps, although 10 amps is more common and on some continental sites the available output may be as low as 5 amps. If your loading exceeds the site supply it may trip the park's circuit breaker. Please check the available mains output with your site operator.

The following items need to be added together if used simultaneously.

#### 230V mains equipment typical consumption figures:

Fridge	0.5 amps
Charger	1.0 amps
Water heater (max)	5.7 amps
Blown air heaters	4.8 amps
Colour TV	2.5 amps
Microwave	3.5 amps
Air conditioning	4.0 amps
Truma Ultraheat (max)	8.3 amps
Kettle	3.2 amps
Alde central heating	10.0 amps

The mains wiring in Lunar caravans manufactured in the UK complies with the IEE Wiring Regulations, 17th edition, and is safe for the use in the UK. In the UK the on/off switching is always positioned in the live wire. Therefore when the switch is off the current is dead.

Correct polarity of the site supply should always be obtained by the use of a non-reversible plug and socket for connecting the cable to the caravan inlet.

Reverse polarity on overseas use: A plug in polarity tester is used to determine if the polarity is reversed, if so and the site connector is of the two pin type with the two metal strips for the earth, then the plug may be unplugged and inserted the other way round which will then reverse the polarity.

Unfortunately the overseas practice is not always to discriminate between live and neutral wires and the plugs are not necessarily non-reversible. They can be inserted the wrong way round. Consequently when switches are turned off the circuits are not dead. People may touch connections thinking that they are safe and they may still receive a shock.

A residual current device is already fitted to your Lunar Caravan. If a fault occurs and anyone makes indirect contact with a live lead the breaker should trip before a dangerous voltage is apparent.

It is essential that you understand the workings of each electrical circuit. Check supply cable terminals are firm and secure.

Check supply cables for wear and damage. Do not attempt modifications to the caravan electrical installation to accommodate a double supply.

### INSTRUCTIONS FOR ELECTRICITY SUPPLY

#### On Arrival at Caravan Site

1. Before connecting the caravan installation to the mains supply, check that:
  - (a) the main supply is suitable for your installation and appliances, i.e. 230 volts AC, frequency 50 Hertz.
  - (b) your installation will be properly earthed. Never accept a supply from a socket outlet or plug having only two pins, or from a lighting outlet.
  - (c) any residual current device (earth leakage circuit breaker) in the mains supply to the caravan has been tested within the last month. In case of doubt, consult the site owner or his agent.



**Note: Always disconnect the electrical connector between the towing vehicle and the caravan before connecting an LV (low voltage) supply to the caravan and before charging the caravan battery by any other means.**

2. Ensure that your caravan mains isolating switch (RCD) is in the off position. The MCB's are the breakers for the individual circuits.
3. Remove any cover from the electricity inlet provided on the caravan, and insert the connector of the supply flexible cable.
4. Remove any cover from the socket outlet provided at the site supply point, and connect the plug (at the other end of the supply flexible cable) to this. Switch on the main switch at the site supply point.

IN CASE OF DIFFICULTY CONSULT AN APPROVED ELECTRICAL INSTALLATION CONTRACTOR (WHO MAY BE THE LOCAL ELECTRICITY COMPANY). IT IS DANGEROUS TO ATTEMPT MODIFICATIONS AND ADDITIONS YOURSELF, LAMPHOLDER PLUGS (BAYONET-CAP ADAPTORS) SHOULD NOT IN ANY CIRCUMSTANCES BE USED.

### On Leaving the Caravan Site

5. Reverse the procedure described in Paragraphs 3 and 4 above.

IT IS IMPORTANT THAT THE MAIN SWITCH AT THE SITE SUPPLY POINT SHOULD BE SWITCHED OFF, THE SUPPLY FLEXIBLE CABLE DISCONNECTED, AND ANY COVER REPLACED ON THE SOCKET OUTLET AT THE SITE SUPPLY POINT. IT IS DANGEROUS TO LEAVE THE SUPPLY SOCKET OR SUPPLY FLEXIBLE CABLE LIVE.

### Periodically

6. Preferably not less than once a year, the caravan electrical installation should be inspected and tested and a report on its condition obtained as prescribed in the Regulations for Electrical Installations published by the Institute of Electrical Engineers.

**Never allow modification of electrical systems or appliances except by qualified persons.**

**Outlet sockets located within the tourer should only be used with a dedicated appliance and not an independent unit.**

**No appliance shall be used outside when connected to an internal socket.**

**YOUR CARAVAN IS NOW SUPPLIED WITH 25 METRES OF MAINS CABLE TO COMPLY WITH BS EN1645.**

### FLEXIBLE WIRING

LIVE	BROWN
NEUTRAL	BLUE
EARTH	GREEN & YELLOW

### FIXED WIRING

LIVE	BROWN
NEUTRAL	BLUE
EARTH	GREEN & YELLOW

### BBQ Point Information

Models equipped with an external barbeque point can be used to power any gas appliance suitable for the gas used in the caravan, at the working pressure shown on the label in the barbecue outlet box. Please note when using the outlet that the fitted regulator will

allow a maximum of 1.5kg per hour of gas to be taken from the gas bottle. Therefore the consumption of gas from both appliances within the caravan and appliance connected to the barbecue point cannot exceed a total of 1.5kg at one time. If you are in any doubt please consult your dealer for advice.





# SERVICES

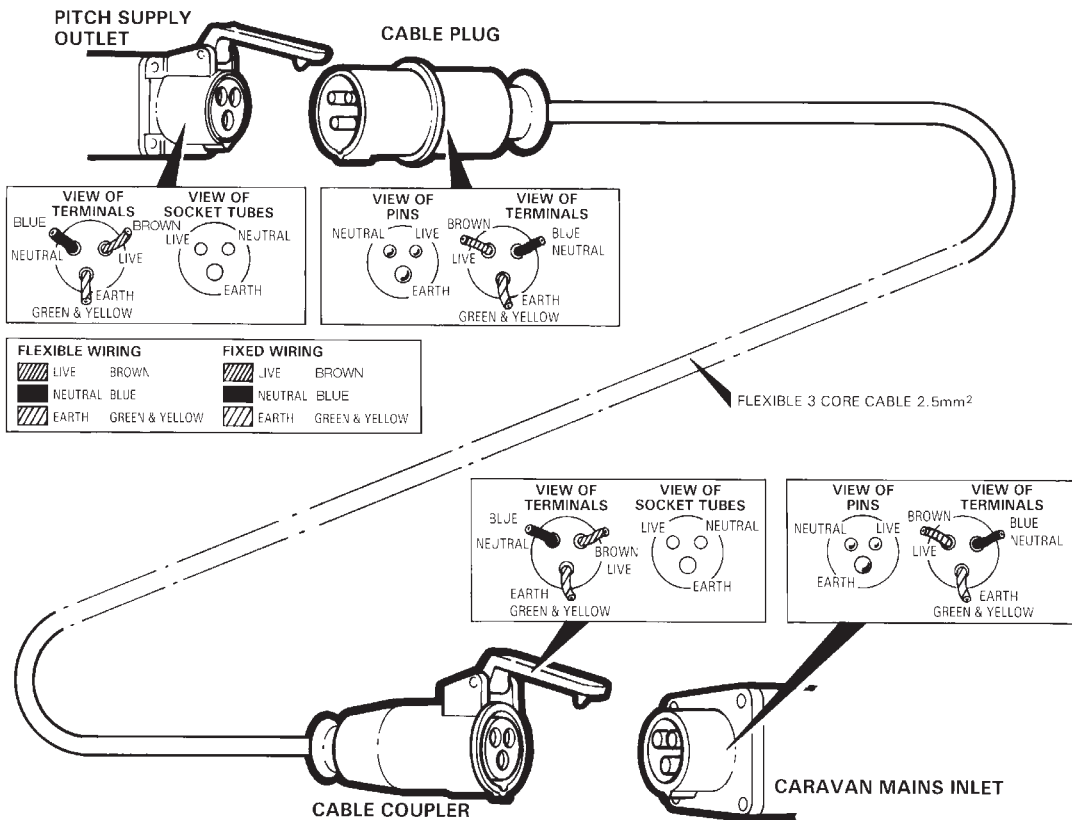



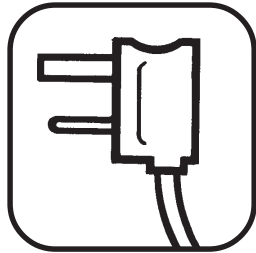

# **ELECTRICS**

Power Control System .....	50
Battery .....	62
Use of Generators .....	63



# ELECTRICS

## EC175 POWER CONTROL SYSTEM

### 1 INTRODUCTION

This section of the handbook will guide you through the operation of the electrical system.

Further technical details are contained later in this document or in the supporting technical manual available from [www.sargentltd.co.uk](http://www.sargentltd.co.uk)

For the safe operation of all electrical equipment within your Leisure Vehicle it is important that you read and fully understand these instructions. If you are unsure of any point please contact your dealer / distributor for advice before use.

The system has a number of key components that you will need to be familiar with before attempting to use the system, these are:

- **The EC175 series Power Supply Unit (PSU)** - a combined mains 230V / 12V consumer unit and controller located in the front bed box.
- **The EC360 or EC350 series Control Panel (CP)** - a remotely located user control panel used to turn circuits on and off and to display battery and water tank information.

### 2 USING THE SYSTEM

The PSU is located in the front offside bed box.

#### 2.1 EC175 Power Supply Unit - Component Layout

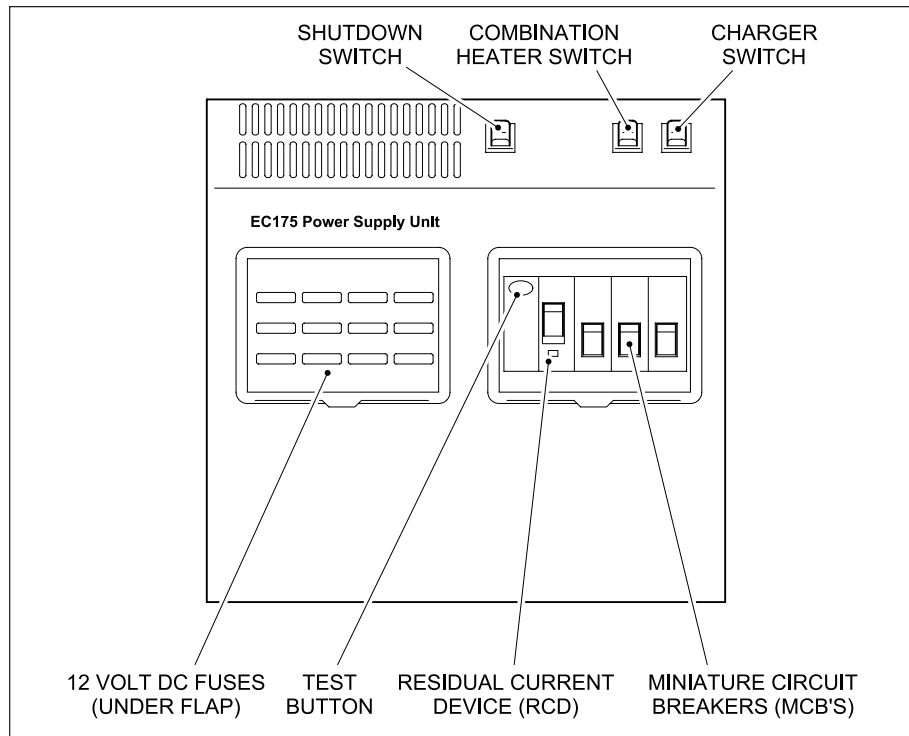



## 2.2 Activating the System

The EC175 system has a shutdown feature that should be used when the vehicle is in storage or is not being used for long periods of time. This allows the leisure electronics to be turned off when not required to save battery power. When in the off state the alarm and tracking system supplies are still active, most other supplies are turned off.

Before using the system please ensure the system shutdown switch is in the on position (button in).

### PSU - 12V Controls

The black system shutdown button is shown on the left. In is on and out is off.

The other two switches are for 230V.

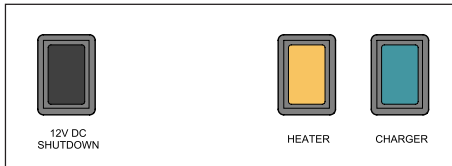

## 2.3 Connecting to the Mains 230V supply and Safety checks

For your safety it is IMPORTANT that you follow these connections instructions each time your Leisure Vehicle is connected to a mains supply. This section assumes that the system is complete and that a Leisure battery has been installed (see 3.3).

A) Ensure suitability of the Mains Supply. Your Leisure Vehicle should only be connected to an approved supply that meets the requirements of BS7671 or relevant harmonised standards. In most cases the site warden will hold information regarding suitability of supply. If using a generator you also need to comply with the requirements / instructions supplied with the generator. Please note that some electronic generators may not be compatible with your leisure system. Further generator operational information is contained elsewhere in this manual.

B) Switch the PSU internal Power Converter OFF. Locate the green 'Charger' power switch on the PSU and ensure the switch is in the off position (button out) before connection to the mains supply.

C) Connect the Hook-up Lead. Firstly connect the supplied hook-up lead (orange cable with blue connectors) to the Leisure Vehicle and then connect to the mains supply.

D) Check Residual Current Device operation. Locate the RCD within the PSU and ensure the RCD is switched on (lever in up position). Press the 'Test' button and confirm that the RCD turns off (lever in down position). Switch the RCD back to the on position (lever in up position). If the test button failed to operate the RCD see section 3.1 & 3.8.

E) Check Miniature Circuit Breakers. Locate the MCB's within the PSU (adjacent to the RCD) and ensure they are all in the on (up) position. If any MCB's fail to 'latch' in the on position see section 3.1 & 3.8.

F) Turn the PSU ON. Locate the black 'Shutdown' button and ensure it is in the on position (press button to change, button in = on, button out = off). Locate the green 'Charger' switch on the PSU and turn to the on position (press button to change, button in = on, button out = off). The charger switch will illuminate when turned on.

G) Check operation of equipment. It is now safe to operate the 12v and 230v equipment.



# ELECTRICS

## PSU - 230V Controls

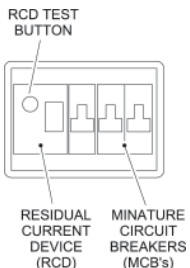

Lever type switch, far left - Residual Current Device (RCD) and main 230V on/off switch.

Push button, far left - RCD test button.

3 x lever switches, right - Miniature Circuit Breakers (MCB). Note the lever colour and MCB rating may vary. See the safety and rating sticker adjacent to the PSU for further details.



12V DC SHUTDOWN



HEATER



CHARGER

Green push switch - Charger switch, this switch turns the 12V battery charger on or off. In is ON out is OFF.

Amber push switch - Heater switch, this switch turns the 230V supply to the space heater / combination heater / central heating system on or off. In is ON out is OFF.

Note the far left 12V DC Shutdown switch is covered in section 2.2.

## 2.4 Operation while driving

The EC175 system is designed to shutdown parts of the system whilst the car engine is running. This is to meet Electro Magnetic Compatibility (EMC) regulations and to ensure the safe operation of the system.

Please ensure the system shutdown switch on the PSU is in the “on” (button in) position before towing (see 2.2). This will ensure the electronic system is active and will therefore be able to control the charging process, supply the refrigerator and monitor other system circuits.



## 2.5 Control Panel - Component Layout



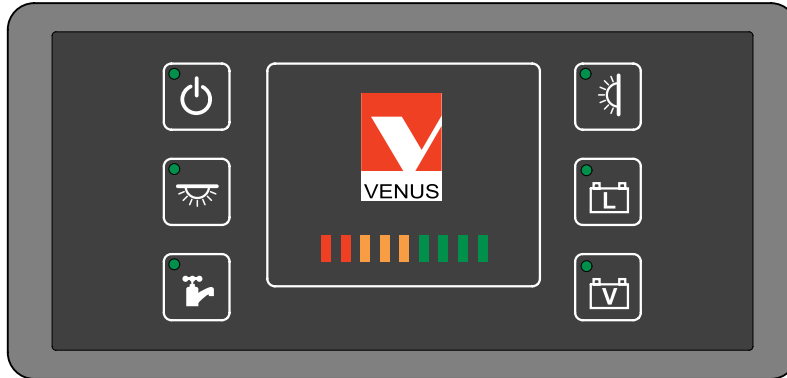



EC350 Digital Control Panel (LED display)





## ELECTRICS

### 2.6 Control Panel Operation

Button	Button Description
	<b>Power Button.</b> Press the power button to turn the leisure power on. Press the button again to turn the power off. The adjacent LED will illuminate when the power is on, and also the voltage of the selected battery will be displayed on the screen. When the car engine is running this LED will flash to indicate the leisure battery is being charged.
	<b>Pump Button.</b> With the power on, press the pump button to turn the water pump on. Press the button again to turn the pump off. The adjacent LED will illuminate when the pump is on, and also the level of the water tank will be displayed on the screen (if the optional onboard water tank is fitted).
	<b>Light Button.</b> With the power on, press the light button to turn the main internal lighting on. Press the button again to turn the lights off. The adjacent LED will illuminate when the lights are on. The lights will be turned on and off automatically each time the power button is operated.
	<b>Awning Light Button.</b> With the power on, press the awning light button to turn the awning light on or off. The adjacent LED will illuminate when the light is on.
	<b>Select / Show Leisure Button.</b> Use this button to select the leisure battery. If the battery is already selected the button will display the battery voltage on the LED bar graph display. The LED next to the button will turn on to show the battery is selected.
	<b>Select / show vehicle button.</b> If the tow vehicle is connected and you need to use the vehicle battery, press this button to select it. If the battery is already selected the button will display the battery voltage on the LED bar graph display. The LED next to the button will turn on to show the battery is selected.



### 3 System Technical Information

The following section provides further technical information relating to the electrical system.

#### 3.1 Residual Current Device & Miniature Circuit Breakers

The Residual Current Device (RCD) is basically provided to protect the user from lethal electric shock. The RCD will turn off (trip) if the current flowing in the live conductor does not fully return down the neutral conductor, i.e. some current is passing through a person down to earth or through a faulty appliance.

To ensure the RCD is working correctly, the test button should be operated each time the vehicle is connected to the mains supply (see section 2.3)

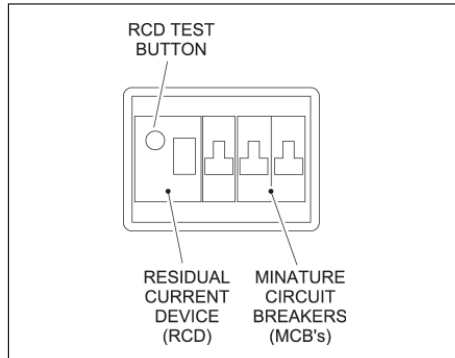

The Miniature Circuit Breakers (MCB's) operate in a similar way to traditional fuses and are provided to protect the wiring installation from overload or short circuit. If an overload occurs the MCB will switch off the supply. If this occurs you should investigate the cause of the fault before switching the MCB back on.

MCB	Rating	Description (cable colour)
1	10 Amps	230v Sockets (white)
2	16 Amps	Combination water heater / central heating system (yellow) Extra 230V sockets (white)
3	10 Amps	Fridge (black) 12V Charger (internally socketed)

#### 3.2 Battery Charger

The EC175PSU incorporates a fixed voltage battery charger / power converter. The battery charger / power converter also powers the leisure equipment when the mains supply is connected. This module supplies 13.8V DC to the leisure equipment up to a maximum of 12 Amps (155 Watts), therefore the available power is distributed between the leisure load and the battery, with the leisure load taking priority as per the following example:

The table below shows the rating and circuit allocation for the three MCB's

Leisure load	Available power for battery charging
3A	9A
6A	6A
9A	3A
12A	0A

#### WARNING

**Under heavy loads the power supply unit case may become hot. ALWAYS ensure the ventilation slots have a clear flow of air. Do not place combustible materials against / adjacent to the EC175. The PSU will shutdown if overheated and will restart automatically when cool.**



## ELECTRICS

### 3.3 Leisure Battery

#### 3.3.1 Type / Selection

For optimum performance and safety it is essential that only a proprietary brand LEISURE battery is used with a typical capacity of 75 to 120 Ah (Ampere / hours). A normal vehicle battery is NOT suitable. This battery should always be connected when the system is in use.

The PSU is configured to work with standard lead acid leisure batteries, and in most cases is also compatible with the latest range of Absorbed Glass Matt (AGM) batteries. Before fitting non-standard batteries please check that the charging profile described in 3.2 is suitable for the type of battery by referring to the battery documentation or battery manufacturer.

The battery feed is fitted with an inline fuse between the battery and the electrical harness, and is usually located immediately outside the battery compartment or within 500mm of the battery. The maximum rating of this fuse is 20A.

#### 3.3.2 Installation & Removal

Always disconnect the 230v mains supply and turn the PSU green charger switch to the off position (button out) before removing or installing the battery.

When connecting the battery, ensure that the correct polarity is observed (black is negative

[-] and red is positive [+]) and that the terminals are securely fastened. Crocodile clips must not be used.

**WARNING: Explosive gases may be present at the battery. Take care to prevent flames and sparks in the vicinity of the battery and do not smoke.**

#### 3.3.3 Operation / Servicing

Under normal circumstances it should not be necessary to remove the battery other than for routine inspection of the terminals and “topping up” of the battery fluid where applicable. Please see instructions supplied with the battery.

**Note:** Do not over discharge the battery. One of the most common causes of battery failure is when the battery is discharged below the recommended level of approximately 10v. Discharging a battery below this figure can cause permanent damage to one or more of the cells within the battery.

To prevent over discharge, the EC175 system incorporates a battery protect circuit that warns the users and then disconnects the batteries when they fall below set values.

#### 3.4 Generator Usage

Caution should be used before connecting a generator to your caravan.

**WARNING: Never start or stop the generator while electrical loads are connected and switched on. Start the engine, let it stabilise and then connect the electrical load. To stop the engine, disconnect the electrical load and let engine stabilise before switching off.**

Whilst some generators use electronic inverter technology, others use a more basic principle to generate the 230V supply. Preference should be to choose a generator which produces a consistent sinusoidal wave form with accurate voltage control.

The Reverse Polarity warning light on the PSU may illuminate when using a Generator. This is a normal side effect when using some types of generator. Instead of connecting the neutral conductor to earth, some generators centre tap the earth connection making both neutral and live conductors 110V above earth. This 110V difference causes the neon polarity indicator to illuminate.

In most cases it is safe to use a generator, but please consult the generator handbook for further information.

#### 3.5 Awning Light Operation

The awning light is controlled by the control panel awning light button. On some models the awning light is also linked to the optional alarm system to enable remote control with the alarm fob.





### 3.6 System Warnings

The system incorporates a number of warnings that are active at specific times. These are summarised below, and also covered by relevant sections of this manual.

Warning	When	Type
Fresh water level low	With pump turned on and fresh water level low (less than 25% full) Only available when an onboard tank is fitted	Message on screen and 30 second audible beep.
Leisure battery voltage low	With control panel power on and leisure battery selected (as active battery) and the voltage level falls below 10V.	Message on screen (or flashing LED bar graph on EC350) and 30 second audible beep.
	With control panel power on and leisure battery selected (as active battery) and the voltage level falls below 9V.	Message on screen (or flashing LED bar graph on EC350) and 30 second audible beep. If no action taken after 30 seconds then the system will switch the power off to prevent severe discharge of the battery.
	<p><b>Note:</b> This is an emergency cut off level to protect the battery from severe damage. You should not rely on this cut off level during normal operation, but manage your power consumption to a discharge level of 11.5V or above.</p> <p>This cut off only applies to power drawn from the battery by the leisure equipment that is controlled by the control panel power switch; it will not protect the battery from discharge by permanently connected equipment.</p>	
Leisure battery voltage high	With control panel power on or off and leisure battery is selected (as active battery) and the voltage level rises above 15.4V	Message on screen (or flashing LED bar graph on EC350) and repeated beeps from the control panel. The beeping will not stop until the fault is cleared.
Vehicle battery warnings	If the vehicle battery is selected instead of the leisure battery, then the same warnings described above for the leisure battery are applied to the vehicle battery.	
Engine running	When the engine is started the system power will be turned off	Message on screen (EC360 only) and power button LED flashing indicating both batteries are connected for charging.



## ELECTRICS

### 3.7 12 Volt DC Fuses

**WARNING: When replacing fuses always replace a fuse with the correct value. NEVER replace with a higher value/rating as this could damage the wiring harness. If a replacement fuse 'blows' do not keep replacing the fuse as you could damage the wiring harness. Please investigate the fault and contact your dealer.**

The table opposite shows the fuse allocation for the 12 fuses fitted to the PSU. Please note that fuses are dependant on PSU versions, so not all fuses may be present or used.

Fuse	Rating	Fuse Colour	Description
1	10 Amps	Red	Water Pumps / Toilet
2	2 Amps	Grey	Permanent Supplies / Electronics
3	5 Amps	Tan	Heater Fans
4	10 Amps	Red	Lights
5	15 Amps	Blue	Fridge Element (during towing)
6	10 Amps	Red	Extractor fans
7	5 Amps	Tan	Ignitions
8	10 Amps	Red	Switched Lights
9	20 Amps	Yellow	Vehicle Battery
10	20 Amps	Yellow	Leisure Battery
11	10 Amps	Red	12V Sockets
12	15 Amps	Blue	Charger

The following table shows details of the fuse(s) located at the Leisure battery.

Fuse	Rating	Fuse Colour	Description
Battery 1	20 Amps	Yellow	Fuse remotely located near battery



### 3.8 Common Fault Table

Fault	Possible Cause	Proposed Fix
No 230 volt output from PSU	Connecting lead between the site and Leisure Vehicle not connected	Check and connect lead as per 2.3C
	RCD switched off	Reset RCD as per 2.3D
	RCD not operating correctly	Check supply polarity; if the RCD continues to fail contact your Dealer as there is probably an equipment or wiring fault
	MCB switched off	Reset MCB by switching OFF (down position) then back ON (up position), if the MCB continues to fail contact your Dealer as there is probably an equipment or wiring fault
	No or deficient supply from site	Contact site Warden for assistance
	Other fault	Contact your Dealer.
Control Panel problems	Control panel has no display	Backlight/illumination may have switched off. Press the power button or select button to reactivate the backlight. Check batteries and fuses, turn PSU shutdown switch and charger switch on and ensure mains supply is connected. Check control panel connecting lead at PSU and behind Control Panel. Contact your Dealer
	12v Power turns off	Battery protect feature has operated to protect the Vehicle battery and or the Leisure battery. See 3.6 Engine has been started, all equipment has been disconnected to meet EMC requirements. See 2.4
	Control panel locked/erratic function	Observe control panel handling instructions. Control panel software may have crashed. Reboot control panel by turning off the PSU isolate switch. Wait 30 seconds then turn the switch back on.
No 12 volt output from PSU	No 230V supply	Check all above.
	Charger not switched on	Turn charger switch on, switch will illuminate
	Battery not connected and / or charged	Install charged battery as per 3.3.
	Power button on control panel not switched on	Turn power on at control panel
	Battery flat / Battery fuse blown	Recharge battery, check fuses, check charging voltage is present at battery.
	Fuse blown	Check all fuses are intact and the correct value fuse is installed as per fuse table
	Equipment switched off / unplugged	Check equipment is switched on and connected to the 12V supply.



# ELECTRICS

## 3.9 Common Fault Table (continued)

Fault	Possible Cause	Proposed Fix
	PSU overheated / auto shutdown operated	Reduce load on system. Allow PSU to cool down. PSU will automatically restart when cool.
	Other fault	Contact your Dealer.
Pump not working	Fuse blown	Replace fuse with correct value as per fuse table.
	Pump turned off	Turn pump on by pressing the pump button at the control panel.
	Setting incorrect	Both the internal and external pump feeds are controlled from the control panel. To alter the setting of the pump switch see your dealer. Ensure the setting matches your desired requirement.

## 3.11 Contact details

Sargent Electrical Services Limited, provide a technical help line during office hours. Please contact 01482 678981 if you require technical help. For out of hour support please refer to the tech support section of the Sargent web site [www.sargentltd.co.uk](http://www.sargentltd.co.uk).

## 4 EC350 Control Panel

In addition to the information contained in section 2.6 (Control Panel Operation), the following section provides further detail information.

### 4.1 LED Bar Graph



The LED Bar Graph opposite displays the voltage of the selected battery.

LED	Colour	Voltage reading
1	Red	<9.5 (<9 LED Flashes)
2	Red	9.5 - 10.9
3	Amber	11 - 11.4
4	Amber	11.5 - 11.9
5	Amber	12.0 - 12.4
6	Green	12.5 - 12.9
7	Green	13.0 - 13.4
8	Green	13.5 - 13.9
9	Green	14.0 - 14.4 (>15.4 LED Flashes)

When the control panel power is on and the leisure battery is selected (Leisure battery button LED on), pressing the leisure battery  button will display the battery voltage on the bar graph.

When the control panel power is on and the vehicle battery is selected (Vehicle battery button LED on), pressing the vehicle battery  button will display the battery voltage on the bar graph.



## 5 TECHNICAL DATA & APPROVALS

### 5.1 Outline specification - EC175PSU & EC350/360 Control Panel

INPUT 230V	230 Volts / 0 to 16 Amps	+ / - 10%
OUTPUT 230V	RCD protected, 3 x MCB outputs of 1 x 16A and 2 x 10A Separate switched channels for water heater, space heater and charger	
INPUT 12V	2 x 20A battery inputs via 2 x 4 way connectors	
OUTPUT 12V	25A total output via multiple switched channels protected by 12 fused outputs	
Built in CHARGER	Input 220-240 Volts AC +/- 10%, Frequency 50 Hz +/- 6%, Current 3A max.  DC Output 13.8 Volts nominal, Current 12 Amps max (155 Watts)	
Signal INPUT	4 x Fresh water level, 1 x Engine running, plus multiple vehicle connections	Fresh water negative sensed
Data IN / OUT	Data communication and power to Control Panel via 8 way connector	
IP rating	IP31	
Operating temperature	Ambient 0 to 35° Centigrade PSU case temperature with full load 65°C Max	Automatic shutdown and restart if overheated/overloaded
EC175 PSU	Overall size (HxWxD) 260 x 273 x 110mm Clearances 75mm above, 20mm below, 50mm left & right	Fixing centres 262 x 224mm Weight 2.2kg
EC350 & EC360 Control Panel	Overall size (HxWxD) 95 x 200 x 25mm Cut-out size (HxW) 82 x 178mm	Fixing centres 190mm Weight 180g



## ELECTRICS

### GENERAL INFORMATION

#### BATTERY

For optimum performance and safety it is essential that only a good quality CARAVAN battery is used. A normal car battery is NOT suitable.

#### WARNING

**One of the most common causes of caravan battery failure is for the battery to be discharged below the recommended level of approximately 10.5 Volts and therefore causing one or more cells to fail.**

Provided the appropriate relay is fitted to your car and the connection is made via the 13 pin plug and socket, a small trickle charge is achieved from car battery to the leisure battery when towing.

The auxiliary battery compartment is located on the offside of the caravan, with easy to fit and clearly identified positive and negative connectors.

It is recommended that a good quality leisure battery is always in circuit when the system is in use.

A heavy duty 12v battery should be purchased to provide power for lights and other electrical appliances. A proprietary

brand leisure battery with a 60, 90 or 110 amp capacity is recommended. (It must have tube venting capability for internal battery boxes).

It should be remembered that batteries suitable for the electrical demands of a caravan differ in design from those for use with a car, and whilst the system may operate with a car battery it is strongly recommended that only a caravan/leisure type battery, maintained in good condition is used. The battery should be kept topped up at all times.

The battery should be positioned in the designated vented compartment and properly secured. When connecting the battery, ensure that the correct polarity is observed (black is negative and red is positive) and that the terminals are securely fastened. (Crocodile clips are not recommended.)

Under normal circumstances it should not be necessary to remove the battery other than for routine inspection of terminals and "topping up".

The AC output of generators is often derived from an AC alternator, rectified to DC then inverted back to AC. In essence this means the output sinewave may not be very smooth and may not run sophisticated electronics

efficiently. Some of the new wave of gensets are more sophisticated in their production of a sinewave output and are more suited to run electronic equipment.

If in doubt consult your genset dealer or manufacturer for advice.

#### WARNING

**Explosive gases may be present at the battery. Take care to prevent flames and sparks in the vicinity.**

#### WARNING

**Switch off all appliances and lamps before disconnecting the battery.**



## GENERATOR GUIDELINES

Lack of regular servicing can be the cause of most generator problems. Gensets under 2kW are mainly dependent on engine speed for output frequency and voltage, poor or no servicing may cause the engine speed governor to run the genset engine too fast. Therefore frequency and output voltage can rise above the specification of the machine data plate, i.e. 240v at 50Hz, This may cause damage to electrical/electronic equipment (such as battery chargers).

A generator should always be run for a few minutes prior to connection with the caravan electrics, to allow it to warm up and the output to settle to a steady level.

## SUPPORT SERVICE

Contact your local dealer.







## FITTED EQUIPMENT

Truma Combi Boiler .....	66
Refrigerators .....	71
Dometic RMS 8500 .....	71
Oven, Hob & Grill .....	78
Thetford C-220 Series Toilet .....	84
Awning Points .....	88
Rooflight .....	88
TV Antenna .....	89
Wall Lights .....	92
Flyscreens/Blinds .....	93
Door Flyscreen .....	93
Body & Window Care .....	94
Condensation .....	94
Badges .....	96
Bunk Beds .....	97
How to Maintain Furniture in a Caravan .....	99



# TRUMA COMBI BOILER

**Note:** Most proprietary items within the caravan will have their own instruction book, the information within the Venus Handbook is an extract of the most relevant aspects.

## IMPORTANT

In the interest of safety, replacement parts for an appliance shall conform to the appliance manufacturer's specifications and should be fitted by him or an authorised agent.

To maximise the use and life of all fitted equipment in your caravan it is essential that any accompanying manufacturers' literature is read fully. All recommended maintenance and preparation procedures should be followed. The information provided in this handbook is only intended as a guide. If in any doubt consult your Venus appointed dealer, particularly before attempting to install EXTRA EQUIPMENT.

## TRUMA COMBI BOILER

### Introduction

The liquefied gas heater 'Truma Combi' is a warm air heater with an integrated hot water boiler (10 litre volume). The burner operates fan supported, which ensures trouble-free function even when on the move.

The heater can be used to heat the room and water at the same time or just heat hot water.

In warmer conditions the water contents are heated using the small burner. Once the

water temperature is reached, the burner switches off.

In winter or in lower temperatures the unit will automatically select the required power setting according to the temperature difference between the temperature set on the control panel and the current room temperature. When the boiler is filled, the water is automatically heated as well. The water temperature will depend upon the operational mode and the heater output.

If the heater is not to be used when freezing conditions are expected, the water system MUST be drained. NO warranty claim will be accepted for cases of frost damage.

**Please refer to Truma Handbook for the operating of Truma control panel and for troubleshooting guide.**

Before using the heating system for the first time please ensure that the 12v system is turned ON at the control panel over the doorway and that the gas cylinder and isolation valve are turned on.

**Note:** If the Truma panel displays a warning triangle due to no gas or electric plugged in, please beware if the heater is tried to re-start 5 times without rectifying the problem, first the panel will lock out for 15 minutes. During the 15 minutes the fault code will keep flashing as opposed to being permanently displayed.

Fig. opposite shows the controls for the Truma Combi Boiler.

If the gas system is leaking or if there is a smell of gas:

- Extinguish all naked flames.
- Open all doors and windows.
- Close all quick-acting valves and gas cylinders.
- Do not smoke.
- Do not activate any electrical switches.
- Ask an expert to inspect the entire system.

Repairs may only be carried out by a certified repairer.

Any modifications to the unit, including the accessories, exhaust duct and cowl, or the use of spare parts and accessories that are important to the operation of the system that are not original Truma parts and failure to follow instructions will cancel any warranty and indemnify Truma of any liability claims.

It also becomes illegal to use the appliance, and in some countries this even makes it illegal to use the vehicle.

The gas supply's operation pressure (30 mbar) must be the same as the unit's operating pressure (see type plate).

The vehicle owner is always responsible for arranging periodic inspections.

Liquefied gas equipment may not be used when refuelling, in multi storey car parks, in garages or on ferries.



During the initial operation of a brand new appliance (or after it has not been used for some time), a slight amount of fumes and smell maybe noticed for a short while. It is a good idea to heat the device up several times and to make sure that the area is well ventilated.

Heat-sensitive items such as aerosols or flammable liquids may not be stored in the same compartment as the heater because this area may be subjected to high temperatures.

## WARM AIR & HOT WATER HEATING

A Truma liquid gas Combi warm-air heater, with integrated hot water boiler, is fitted and operates on LPG and/or 230V electricity depending on the chosen mode of operation.

In winter operation the heater can be used to heat the room and simultaneously warm water. If only warm water is required, select summer operation.

At a temperature of approximately 3 deg C the automatic frost control safety/drain valve will open and drain the boiler.

Three different options are available for operating the unit.

Gas operation only: Propane/butane for autonomous use.

Electrical operation only: 230V for stationary use on camp sites.

Mixed operation: Gas and electrical operation - only possible in winter mode.

### Winter operation

In winter operation, the unit automatically selects the required power setting according to the temperature difference between the temperature set on the control panel and the current room temperature. When the boiler is filled, the water is automatically heated as well. The water temperature depends on the selected operation mode and the heater output.

All three energy selection options can be used for winter deployment.

With gas operation the unit automatically selects the output level that is required.

Depending on the fuse protection at the camping site, power of 900W (3.9A) or 1800W (7.8A) can be manually selected for electrical operation.

If more output is required (e.g. heating up or low outside temperatures) gas or mixed operation should be selected so that enough heating power is always available.

With mixed operation, 230V electrical operation is preferred if the power requirement is low (e.g. for maintaining the room temperature). The gas burner is not enabled until the power requirement is higher, and is the first to switch off during heat-up operations.

### Summer operation (boiler operation only)

Gas operation or 230V electrical operation is used for hot water preparation. The water temperature can be set to ECO mode (approximately 40 deg°C) or HOT mode (approximately 60°C).

With gas operation the water is heated at the lowest burner setting. Once the water temperature is reached, the burner switches off.

Depending on the fuse protection at the camping site, power of 900W (3.9A) or 1800w (7.8A) can be manually selected for electrical operation.

**Note:** Mixed operation is not possible. With this setting the unit automatically selects electrical operation. The gas burner is not enabled.

### Before operation

**Note:** Heating is possible without restrictions with gas, electrical and mixed operation, with or without water.

Check to make sure the cowl is unobstructed. Be sure to remove any covers that may be present.

Turn on the gas cylinder and open quick-acting valve in the gas supply line.

Check whether the power supply fuse protection on the camp site is adequate for the 900W (3.9A) or 1800W (7.8A) that have been selected using the power selector switch.

The cable drum must be fully unwound in order to prevent the power cable from overheating.



# TRUMA COMBI BOILER

## OPERATING INSTRUCTIONS

The heater is controlled by the digital operating display and control unit fitted above the entrance door.

### Initial operation or activation after a power cut

After the operating voltage has been connected, the unit will beep and the display remains dark. To switch on, press the  key and the main screen will appear.

### Function description

**Note:** More details regarding the operating modes you will find in the operating instruction of your Combi.

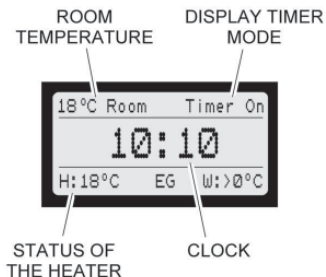





## Main Screen

- Room temperature: Display on when the heater is active.
- Timer: Display on when the timer is active.
- Clock: Only if the clock has been set, otherwise the Truma logo will appear in the display.

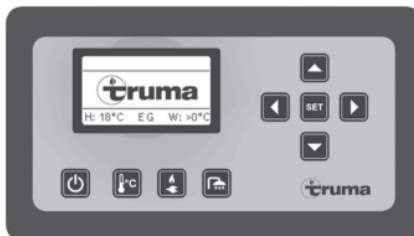
Status of the heater:

- H: Set room temperature (eg. 18°C)
- EG: Energy selection (E=Electro, G=Gas)
- W: Set water temperature.



-  Selection key upwards to select functions or set values
-  Selection key downwards to select functions or set values
-  Selection key backwards to select values
-  Selection key forwards to select values



## On/Off

- Display and heater is switched on and/or off
- The clock is shown when the time is set
- After an interruption in the operating voltage, the display and the heater are switched off. If the time is shown, this needs to be set.

- Green LED shines when the heater is on
- Green LED flashes when the heater is after-running
- Red LED shines when there is a malfunction

## Manual mode

- In manual mode, the heater is controlled via the 4 keys below the display.
- It is not necessary to set the time because the Truma logo is shown in the display instead of the time.

**Note:** A pre-selection between summer/winter operation must be made via the set-up.



## Room temperature

When the menu is selected the yellow LED shines.

The current set room temperature is displayed and can be changed.



Key increases the room temperature (max. 30°C) by 1°C

Key reduces the room temperature (min. 5°C) by 1°C

A change in the room temperature needs to be confirmed with

## Energy selection

When the menu is selected the yellow LED shines.

Depends on summer/winter operation (see setup).

- Use key or to select the energy source and confirm with
- Bar shows current mode

## Summer operation

230V - 4A (electro mode 230V, 900W)  
 230V - 8A (electro mode 230V, 1800W)  
 Gas powered

## Winter operation

230V - 4A (electro mode 230V, 900W)  
 230V - 8A (electro mode 230V, 1800W)  
 Gas powered  
 230V - 4A and gas (mixed operation gas and electro mode 900 W)  
 230V - 8A and Gas and gas (mixed operation gas and electro mode 1800W)

**Note:** If electro or mixed operations are selected and there is no 230V power supply, the heating will not function.

## Water temperature

When the menu is selected the yellow LED shines.

During the heating-up phase, the set water temperature flashes in the main screen.

- Use key or to select the water temperature and confirm with
- Bar show current mode

Depends on summer/winter operation (see setup)

## Summer operation

Water - ECO mode = approximately 40°C  
 Water - HOT mode = approximately 60°C

## Winter operation

Water > 0°C (heating **without** controlled water temperature, heating has priority)

Water 60°C

## Timer mode

- The heater runs in timer mode as soon as one or both timers have been activated in the setup.
- "Timer On" appears in the main screen.
- The heater is only active in the set time window (active timer).

- Only the energy selection can be changed in the case of an active timer.
- Only the energy selection can be changed in the case of an active timer.
- A change in the room or water temperature will automatically switch the control system into manual mode.

## Set up

In the main screen display you can enter the setup menu via the setup key.

The following settings can be made:

Back (return to main screen)

**Timer 1 on/off** (select on/off wahlen)

**Timer 2 on/off** (select on/off wahlen)

**Summer / Winter** (select summer/winter)

## Set clock

### Set timer 1

Back (Return to main screen)  
 Start (Set start time)  
 Stop (Set stop time)  
 Water (Set water temperature)  
 Temp (Set room temperature)

The timer settings can be made every day until the timer is switched off. If the room or water temperature is changed outside the timer menu, the timer is automatically switched off.



# TRUMA COMBI BOILER

## Set timer 2

- Back (Return to main screen)
- Start (Set start time)
- Stop (Set stop time)
- Water (Set water temperature)
- Temp (Set room temperature)

The timer settings can be made every day until the timer is switched off. If the room or water temperature is changed outside the timer menu, the timer is automatically switched off.

**Buzzer on/off** (select  on/off)

**Backlight** (brightness levels 0-9)

**Note:** If no action is taken, the display switches back to the main screen after a few seconds. The lighting switches off after a short delay.

## Troubleshooting

Fault	Rectification / Cause
Clock is not shown	Set clock
Activated timer is not shown any more	Power supply was interrupted
Room temperature is not shown	Heater not active
Device does not react any more	Interrupt power supply for 10 seconds
Heater / display does not react	Check 12V supply voltage

If these measures do not rectify the problem, please contact the next Truma Service point (see Truma service book or [www.truma.com](http://www.truma.com)).

## Further information

see operating instructions Combi 4E / Combi 6E

## Maintenance

Clean the panel with a dry and fluff-free cloth.



If your Control Panel displays the I-Net ready logo in the bottom right corner, please speak to your dealer or Truma representative for the added benefits you can enjoy as upgrades to your factory system.



## REFRIGERATORS

### Winter Operation - Dometic Refrigerators

- ⚠ Please check that the ventilation grilles or the flue outlets are not blocked by snow, leaves etc.

### DOMETIC REFRIGERATOR MODEL RMS 8500

#### Cleaning

Before starting up the refrigerator, it is recommended to clean it inside and repeat this at regular intervals. Use a soft cloth and lukewarm water with a mild detergent. Then wipe out the appliance with clean water and dry thoroughly.

- ⚠ To avoid deterioration of materials: Do not use soap or hard, abrasive or soda-based cleaning agents. Do not allow the door seal to come into contact with oil or grease.

#### Operating modes and use of the refrigerator

- This refrigerator is equipped to operate on three power modes: AC mains power (230V), 12V DC or gas (propane/butane liquid gas).

- Select the desired power mode by the energy selector switch (battery igniter type models) or the MODE button (MES, AES). Appliances with automatic energy selection (AES) are additionally provided with automatic mode function. The AES system automatically selects the best energy source for each particular situation.
- The cooling unit is silent in operation.
- The refrigerator works reliably on slopes of up to 6 degrees (5 degrees with models starting from 140 litres capacity).
- When the appliance is started for the first time, there may be a mild odour which will disappear after a few hours. Air the living space thoroughly.
- The refrigerator will take several hours to reach its operating temperature in the cooling compartment.

#### Control elements of energy selections (BATTERY IGNITER, MES and AES)

Manual energy selection/manual ignition (RM 8500) battery igniter:

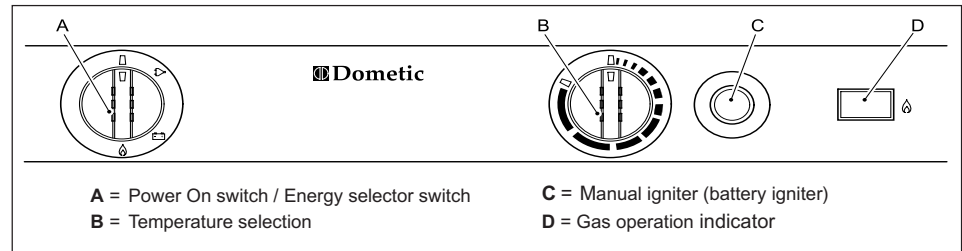



# REFRIGERATOR

## Explanation:

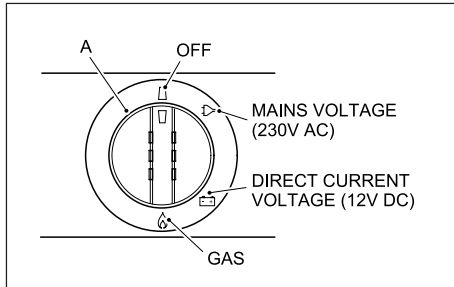

The refrigerator is equipped to operate on mains power, 12V DC or liquid gas. Select the desired power supply by turning the energy selector switch A. The energy selector switch A has four settings: OFF, AC mains voltage, DC (battery), gas (liquid gas).



## Electrical operation

Appliances with battery igniter (manual energy selection)

Switch on the appliance by turning the energy selection switch A clockwise to position:

-  230V operation,
-  12V operation

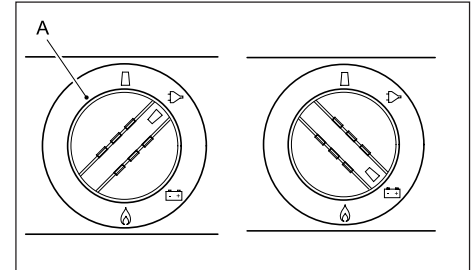

- In order to prevent discharge of the on-board battery, 12V operation should only be used while the motor is running.

## Gas operation (liquid gas)



- ▲ The refrigerator must be operated using liquid gas (propane, butane (no natural gas or town gas). When using LPG gas, please consider that the burner needs cleaning at shorter intervals due to the gas combustion method (semi-annual recommended).
- ▲ In Europe, gas operation is permitted while travelling only on the condition that the gas system of the vehicle is equipped with a hose rupture protection. The national regulations of the respective country must be observed.
- ▲ For physical reasons, ignition faults could occur starting from an altitude above sea level of approx. 1000m/3280 ft. (No malfunction!)
- ▲ On the initial refrigerator start-up or after a cylinder change, air may be trapped in the gas line. To purge the air from the lines, switch on the refrigerator and any other gas appliances (e.g. stove) for a short time. The gas ignites without delay.
- ▲ As a basic rule, gas operation is prohibited in petrol stations.
- ▲ **Note:** Where windows are positioned above flue out it is recommended that the window is not left open for long periods when operating the fridge on gas.





## Prior to starting the refrigerator in gas mode:

- Open the gas cylinder valve.
- Open the shut-off valve for gas supply to the refrigerator.

## Appliances with battery igniter:

1. Turn the rotary selector switch **A** to position .
2. Turn the temperature selector **B** clockwise and push. Keep the controller button depressed.
3. Then, press knob **C** of battery igniter down and keep it depressed. The ignition process is activated automatically.
4. Once the flame ignites, the pointer of galvanometer **D** begins moving into the green range. The refrigerator is operational. Keep knob **B** depressed for approx. 15 seconds and finally release it.

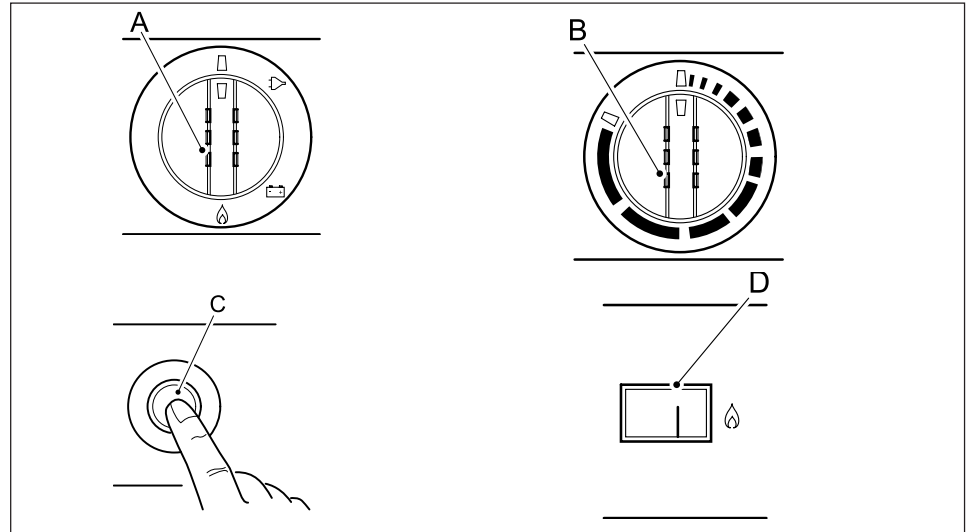

**Each refrigerator with manual ignition is equipped with an automatic flame safety valve which interrupts the gas supply after approx. 30 seconds when the flame has extinguished.**

## Door Locking

Open the door by pressing the locking button and pull open.

Shut the door again by pushing it to close. The snapping into the lock can be heard.

While the vehicle is parked, the locking hook can be fixed to facilitate opening of the door.





# REFRIGERATOR

## Fixing and releasing the door lock hook when parking the vehicle

If the vehicle is parked for a longer period of time, the locking hook may be clamped by means of a lockbar. The door may now be opened by just pulling it without need of pressing the locking button.

Restore the original position by pushing the hook down.



- ▲ As a basic rule, shut and lock the refrigerator door before commencing your journey.

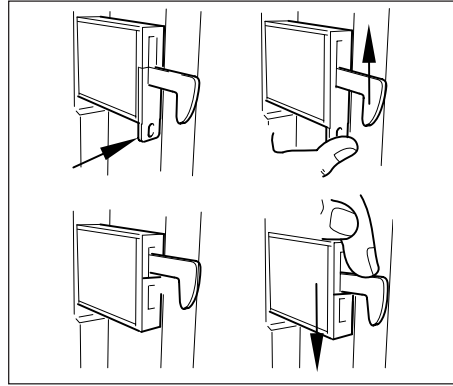

## Removable freezer compartment

To enlarge the cooling space, just remove the freezer compartment.

Unlock the freezer compartment on both sides and pull it out.

Store the freezer compartment safely in order to prevent damage.

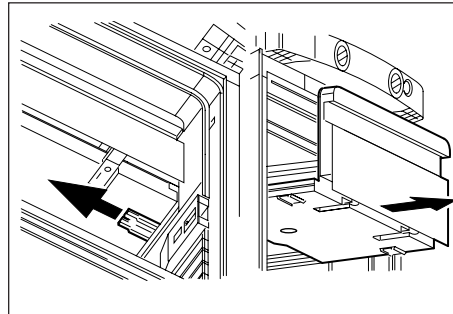

## Positioning the storage racks

The storage racks may be pulled out by smoothly lifting them and may be positioned as desired.

- ▲ Once the freezer compartment is removed, an additional storage rack may be installed. The storage rack is a piece of extra equipment and may be obtained from Dometic.

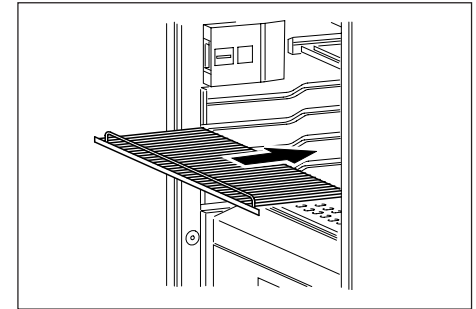



## Exchange of the igniter's battery

Unlock the battery by depressing and turning the button (C) approximately 90 degrees anti-clockwise.

Remove cap and exchange battery (1.5V AAA / R3 / Micro). Observe correct polarity.

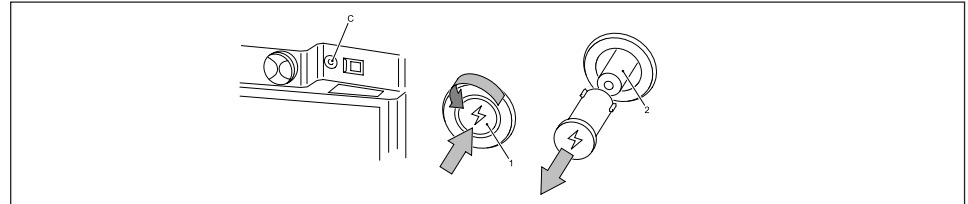

## Shutting off the refrigerator

- For battery igniter models, set energy selector switch **A** to position 'OFF'. The appliance is switched off.
- Press the 'MODE' button to switch off MES and AES models. Keep button **A** pressed for two seconds. The display disappears and the appliance is fully switched off.
- Release the locking mechanism of the door lock by pushing it and shift it to the front. If the door is shut in this position, a small gap is nevertheless kept open to prevent formation of mildew.
- If the refrigerator is to be taken out of service for an extended period of time, close the onboard shut-off valve and the cylinder valve.

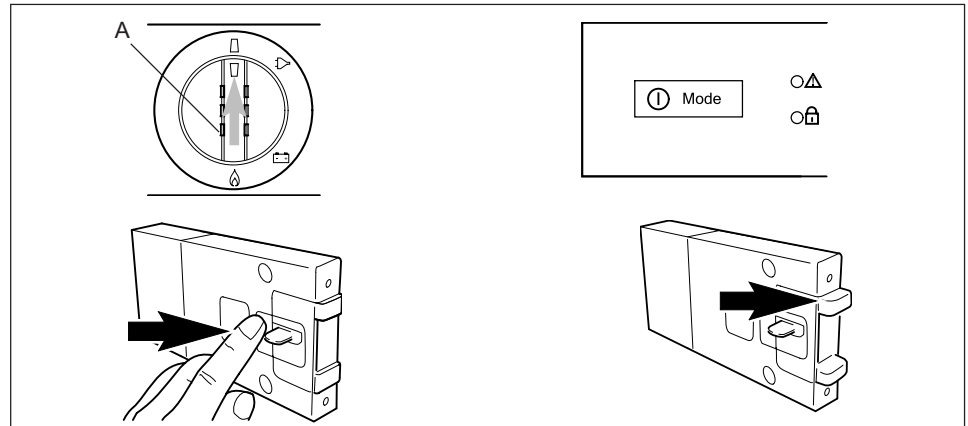

## Lighting

If the door is open for more than two minutes, the sensor-controlled interior lighting is automatically cut off (except for models with battery igniter).

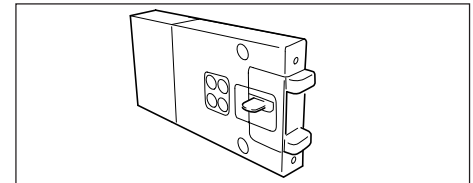



# REFRIGERATOR

## Troubleshooting

Before notifying the authorised Service Centre, please check whether:

- ▲ The instructions in the section “Operating the refrigerator” have been followed.
- ▲ The refrigerator is level.
- ▲ It is possible to operate the refrigerator with any available power source.

### **Failure: The refrigerator does not cool sufficiently.**

#### *Possible cause*

- a) Inadequate ventilation to the unit.
- b) Thermostat setting is too low.
- c) The condenser is heavily frosted.
- d) Too much warm food has been stored inside within short period of time.
- e) The appliance has been running for only a short period of time.
- f) Ambient temperatures too high.

#### *Action you can take*

- a) Check that the ventilation grilles are not covered.
- b) Set thermostat to a higher level.
- c) Check that the refrigerator door closes properly.
- d) Allow warm food to cool down before storage.
- e) Check whether the cooling compartment works after approximately 4-5 hours.
- f) Regularly remove ventilation grilles.

### **Failure: The refrigerator does not cool in gas operation mode.**

#### *Possible cause*

- a) Gas cylinder empty.
- b) Is the supply shut-off device open?
- c) Air in the gas pipe?

#### *Action you can take*

- a) Change gas cylinder..
- b) Open the shut-off device.
- c) Switch off the appliance and start again. Repeat this procedure 3-4 times, if necessary.

### **Failure: The refrigerator does not cool in 12V operation.**

#### *Possible cause*

- a) On-board fuse defective.
- b) On-board battery discharged.
- c) Engine not running.
- d) Heating element defective (please also refer to failure indication).

#### *Action you can take*

- a) Fit new fuse.
- b) Check battery, charge it.
- c) Start engine.
- d) Please inform the Dometic Customer Services.



## Failure: The refrigerator does not cool in 230V operation.

### Possible cause

- a) On-board fuse defective.
- b) No connection to supply voltage.
- c) AES: gas operation despite connection to the supply voltage?
- d) Heating element defective (please also refer to failure indication).

### Action you can take

- a) Fit new fuse.
- b) Establish power connection.
- c) Appliance switches to gas operation due to insufficient supply voltage (automatically switches back to 230V operation).
- d) Please inform Dometic Customer Services.

## Maintenance

- Works on gas components and electrical installation may only be carried out by authorised personnel. We recommend to contact your Dometic Service Centre.
- EN 1949 stipulates that the appliance's gas equipment and its associated fume system must be inspected after installation and a certificate issued.
- Afterwards a qualified technician must inspect according to EN 1949 every two years and a certificate issued.

## Low Temperatures and Winter Covers

Check that the ventilation grilles and the exhaust (1) duct system (2) have not been blocked by snow, leaves, etc.

Cold air can restrict the performance of the unit. Install the winter covers (3) if you discover any loss of cooling performance when outdoor temperatures are low. This protects the unit against excessively cold air.

Ventilation grille LS100

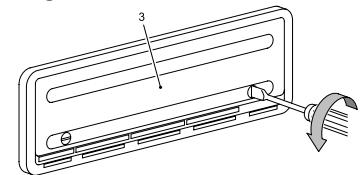
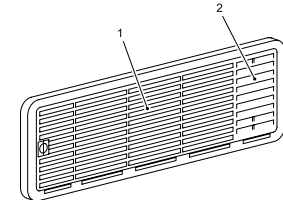

Ventilation grille LS200 + winter cover

**CAUTION:** Refrigerators up to 130l capacity  
\*: Do not install the top winter cover during gas operation.



# OVEN, HOB & GRILL

## OVEN, HOB AND GRILL

### Safety

- This appliance may be used by children aged 8 years or older and persons with reduced physical, sensory or mental capabilities and/or lack of experience and knowledge only if they are supervised or have been given instructions on the safe use of this appliance and understand the potential hazards.
- Keep children younger than 8 years away from the appliance, except under constant supervision.
- Do not allow children to play with the appliance.
- Do not allow children to clean or maintain this equipment unattended.
- Use only parts supplied by the manufacturer.
- Do not change or adjust anything on the appliance, unless the change is authorised by the manufacturer or its representative.
- If the power cord is damaged, it must be replaced by the manufacturer, its service agent or similarly qualified persons in order to avoid a hazard.
- Use the appliance for cooking only and not for anything else, for example room heating. This can lead to carbon

monoxide poisoning and overheating. The manufacturer cannot be held liable for damage resulting from improper use or incorrect setting of the controls.

- This appliance is not intended to be operated by means of an external timer or separate remote-control system.
- The use of this gas cooking appliance results in the production of heat, moisture and products of combustion in the room in which it is installed. Ensure the room has sufficient ventilation when the appliance is in use. During prolonged use, additional ventilation may be needed by opening a window or increasing the extraction force of the hood.
- Never extinguish a cooking fire with water. Turn the burner off and cover the flame with a lid or a fire blanket.
- The appliance and its accessible parts become hot during use. Care should be taken to avoid touching heating elements.
- The cooking process must be supervised continuously. Unattended cooking on a hob with fat or oil can be dangerous and may result in fire. Do not leave the appliance unattended when in use.
- The use of inappropriate hob guards can cause accidents.
- Danger of fire, do not store items on the cooking surface of the hob.
- The food shelves and trays in the

appliance are hot during and after use. Allow all parts to cool before touching them, as this can cause serious injury. Always use oven gloves when removing the shelves and trays.

- Do not store items in the appliance.
- Do not put heavy objects on the open appliance door.
- The appliance and accessible parts become hot when the grill is in use. Young children should be kept away.
- **CAUTION:** hot surfaces. Door must be open when grill is in use.
- In the event that abnormal drift in cooking temperature of the oven is observed, have the thermostat checked by a qualified

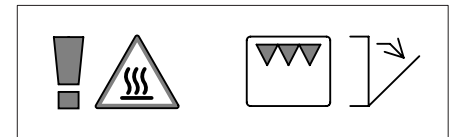

service engineer.

- Care should be taken not to overload the oven, allowing adequate spacing to ensure free circulation of heat.
- Do not use steam cleaners or pressure washers to clean the appliance. See for instructions.



- Do not allow oil or fat to build up on the appliance. Clean the appliance after each use.
- The glass lid may snap shut towards the end of lowering due to the travel-lock action of the hinges. Make sure all fingers are clear of the appliance when closing the lid.
- Do not use harsh abrasive cleaners or sharp metal scrapers to clean the surface of the glass, since they can scratch the glass surface which may result in shattering of the glass.
- Remove any spillage from the glass lid before opening the lid.
- Do not shut the glass lid when the burners are lit or still warm.
- Ensure that the appliance is connected to the 12V DC battery for the spark ignition.
- Ensure that the pan supports are positioned properly.
- Ignite the gas burners and let them burn to expel odours and vapours first.
- Ignite the burner and heat the grill for about 20 minutes to eliminate any residual factory lubricants that might impart unpleasant smells to the food being cooked. Smoke may occur during this procedure. Open any windows and turn on mechanical ventilators to help remove the smoke.
- Ignite the burner and heat the oven for about 30 minutes at 200°C to eliminate any residual factory lubricants that might impart unpleasant smells to cooked food. Smoke may occur during this procedure. Open any windows and turn on mechanical ventilators to help remove the smoke.



## Before Use

Before using the appliance.

- Ensure that all packaging materials have been removed.
- Clean the appliance with warm water and household detergent and dry carefully with a soft cloth.
- Ensure that the gas supply is connected and turned on.
- Prime the hotplate by switching on the hotplate for a short period, without a pan, to harden and burn off the coating. Use a medium to high setting for 3-5 minutes. Allow adequate ventilation to disperse any smoke that occurs during this process. Allow the hotplate to cool.
- Season the hotplate by heating the hotplate

for 30 seconds on a medium setting and then switching off. Pour a minimal amount of unsalted vegetable oil onto a clean dry cloth or paper towel and apply a thin coat of oil to the hotplate surface. Wipe off any excess oil, then heat the hotplate on a medium setting for 1 minute. Occasional seasoning will help to maintain the hotplate's appearance.

## Oven shelf

- The oven shelf allows good circulation at the rear of the oven.
- A raised bar at the rear of the shelf prevents trays or dishes making contact with the back of the oven.
- To remove a shelf, pull it forward until it stops, raise at the front and remove.
- To place a shelf in the oven, lower it at the front and slide it backward until it stops.

Only use LPG (Liquefied Petroleum Gas). The appliance operates on propane or butane. Propane is preferred over butane, because butane provides poor performance at an ambient temperature below 10°C and cannot be used at an ambient temperature below 5°C.





# OVEN, HOB & GRILL

## Use of the burners

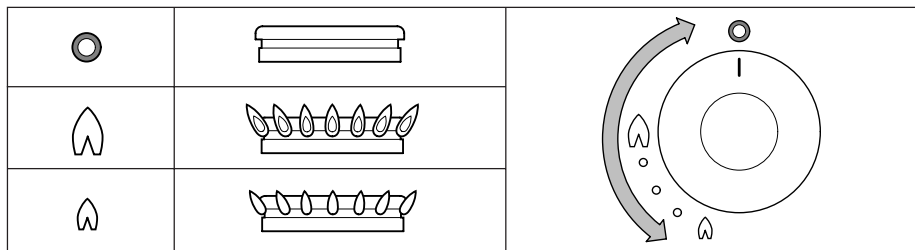

### Turning on:

- Push and turn the control knob.
- Turn the control knob anti-clockwise to the full rate position.
  - For spark ignition models: Push the ignition button.
  - For non-ignition models: Hold a lit match or gas match to the burners.
- Keep the control knob pressed for about 10-15 seconds and then release it.
- Adjust the height of the flame.



If the burner accidentally extinguishes turn the control knob to the 0 position and wait at least 1 minute before re-igniting the burner.



If the burner has not lit within 15 seconds turn the control knob back to the 0 position and release it. Wait at least 1 minute and repeat the steps above to turn on the appliance.

### Turning off:

- Turn the control knob clockwise to the 0 position to turn off the burner.



Always make sure the control knob is in the 0 position when you have finished using the gas burners.



Do not shut the glass lid when the burners are lit or still warm.

## Use of the electric hotplate (if applicable)

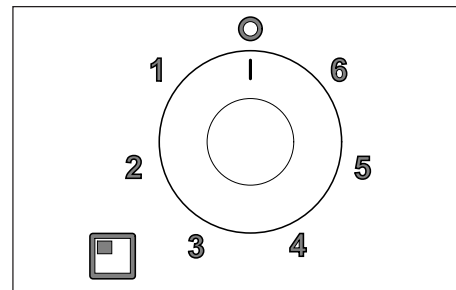

For the exact location of the control knob, see:

### Turning on:

- Rotate the control knob either clockwise or anti-clockwise to the required position (1-6).

For maximum efficiency, a correctly sized pan with a flat heavy gauge base should be used. The pan size should be the same or slightly larger than the hotplate (up to 1"/2.5cm oversize).

### Turning off:

- Turn the control knob to the 0 position to turn off the hotplate.



Always make sure the control knob is in the off position when you have finished using the hotplate.



Do not shut the glass lid when the hotplate is turned on or still warm.





## Use of the grill

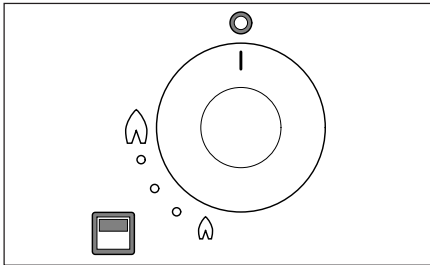

For the exact location of the control knob, see:

### Turning on:

- Open the door and push the control knob.
- Continue pressing the control knob and turn it anti-clockwise to the full rate position.
  - For spark ignition models: Push the ignition button.
  - For non-ignition models: Hold a lit match or gas match to the burner.
- Keep the control knob pressed for about 10-15 seconds and then release it.
- Adjust the required heat setting.
- Depending on the food to be cooked, the correct grilling height can be achieved by inverting the pan trivet into either the high or low position.
- The grill pan supplied is multi-functional, for use in grill or oven and the handle

design allows removal or insertion whilst the pan is in use. Always remove the handle when the pan is in use.

- The grill door must remain open when lighting and using the grill.
- If the burner accidentally extinguishes turn the control knob to the 0 position and release it. Wait at least 1 minute and repeat the steps above to turn on the appliance.
- Although the grill heats up quickly, it is recommended that a few minutes preheat be allowed.
- It is normal for the flames on this burner to develop yellow tips as the grill heats up.

### Turning off:

- Turn the control knob clockwise to the 0 position to turn off the burner.



Always make sure the control knob is in the 0 position when you have finished using the grill.

## Use of the oven

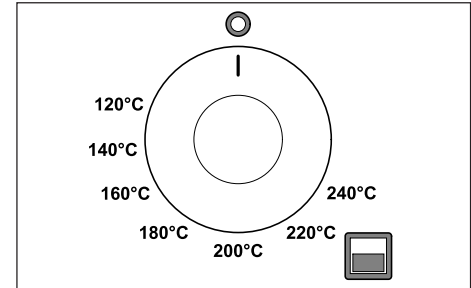

For the exact location of the control knob, see:

### Turning on:

- Open the door and push in the control knob.
- Continue pressing the knob and turn it anti-clockwise to the full rate position. (240°C, gas mark 7/9).
  - For spark ignition models: Push the ignition button.
  - For non-ignition models: Hold a lit match or gas match to the burner.
- Keep the control knob pressed for about 10-15 seconds and then release it.
- Adjust the required heat setting.
- Place the oven shelf in the required position and close the door.



## OVEN, HOB & GRILL



Ignition must always be carried out with the oven door open.



If the burner accidentally extinguishes turn the control knob to the 0 position and wait at least 1 minute before re-igniting the burner.



If the burner was not lit within 15 seconds turn the control knob back to the 0 position and release it. Wait at least 1 minute and repeat the steps above to turn on the appliance.

Although the oven heats up quickly, a 10-minute preheat is recommended. The oven should reach full temperature in about 15-20 minutes.

### Turning off:

- Turn the control knob clockwise to the 0 position to turn off the burner.



Always make sure the control knob is in the 0 position when you have finished using the oven.

### Safe cooking

- Do not allow cooking vessels to overlap the edges of the appliance - use the correct sizes of pans and position them centrally over the burners.
- Ensure that there is at least a 10mm gap between the pans and the edges of the hob.
- Turn the pans so that the handles do not overhang the front of the appliance.
- Ensure that the flame of the gas burner heats the bottom of the pan, not the sides.
- The pans and trays supplied with this appliance are the maximum sizes. Do not use larger pans and trays. They may restrict good circulation of heat, which may increase cooking times.
- The oven shelf allows good circulation at the rear of the oven.
- A raised bar at the rear of the shelf prevents trays or dishes making contact with the back of the oven.
- To remove a shelf, pull it forward until it stops, raise at the front and remove.
- To place a shelf in the oven, lower it at the front and slide it backward until it stops.
- Do not leave the appliance unattended when in use.
- Do not use the appliance while the vehicle is moving.
- Turn the control knob back to the 0 position after cooking.

- Keep the appliance clean and prevent accumulation of grease and food scraps.



Never cover slots or holes in the appliance and never cover a shelf with materials such as aluminium foil. That restricts the airflow and may cause carbon monoxide poisoning.



The food shelves and trays in the appliance are hot during and after use. Allow all parts to cool before touching them, as this can cause serious injury. Always use oven gloves when removing the shelves and trays.



### Temperature control

The temperature in the oven is controlled by a thermostatic gas tap and is variable over the range 120°C to 240°C.

The table overleaf provides a guide to the approximate temperatures at each of the shelf positions with respect to the gas mark setting. Good use can be made of the temperature variation between the shelf positions, as several dishes requiring different temperatures may be cooked at the same time. In this way maximum benefit can be obtained from the gas used to heat the oven.



## Temperature zones

Gas Mark				Dish
1/4 - 1/2	90°C	110°C	130°C	Meringues
1	110°C	130°C	150°C	Stewed fruit
2	120°C	140°C	160°C	Rich fruit cake, rice pudding
3	130°C	150°C	170°C	Baked custard, shortbread finger
4	140°C	160°C	185°C	Victoria sponge
5	155°C	180°C	200°C	Whisked sponges, ginger nuts
6	170°C	190°C	215°C	Short crust pastry
7	185°C	210°C	230°C	Bread, scones, flaky pastry
8	200°C	220°C	245°C	Puff pastry
9	215°C	240°C	260°C	Quick browning



Care should be taken not to overload the oven, allow adequate spacing to ensure free circulation of heat.



When roasting with aluminium foil ensure the foil does not impair circulation of heat or block any oven flue outlet.

## Maintenance and cleaning

Thetford recommends an annual inspection service by an approved service centre. Between annual servicing, clean the appliance regularly after use. Before any cleaning work is started, the appliance should have been left to cool and be disconnected from the gas and electrical supplies.

- Always remove any spills or contamination immediately after use with soap and hot water. Towel dry the surface with a soft cloth.
- Use a non-abrasive multi-purpose cream cleaner and a nylon scourer pad to clean more stubborn dirt or grease.

- Use a proprietary stainless steel cleaner or polish to remove superficial surface scratching.
- Do not use abrasive cleaners, metal scouring pads or hard brushes. They could damage the appliance.
- If you clean the burner rings, ensure that the holes are not clogged.

- Do not use harsh abrasive cleaners or sharp metal scrapers to clean the glass surface, since they can scratch the glass surface which may result in shattering of the glass.
- Do not leave wet cloths, cleaning pads, residues of food or cleaning products or other dirt to dry on the surface. It can cause pitting, marking or even rusting.
- Always clean in the direction of the brushed finish and not across the grain.
- Cleaning agents containing bleach should not be left in contact with stainless steel.
- Mineral content in water (such as iron or lime scale) can affect the appearance of the metal.
- Remove any spillage from the glass lid before opening the lid.
- The control knobs can be removed for cleaning. The knobs are easy to replace.

## Troubleshooting

Problem	Possible cause	Solution
Burners do not burn evenly	Gas bottle is empty Gas tap is closed Burner caps are not correctly positioned Burners are wet or clogged	Change gas bottle Open tap Allow caps to cool, then reposition them Burners are wet or clogged
Spark ignition does not spark	12V DC battery is discharged Connections are loose Ignition points are wet or dirty	Charge battery Secure connections Dry or clean ignition points
Control knobs do not function	Knobs are mounted incorrectly	Install knobs correctly



# THETFORD TOILETS

## THETFORD C-220 SERIES CASSETTE TOILET INTRODUCTION

The Thetford Cassette Toilet is a high quality product. It is user-friendly, meets high quality standards and gives you all the convenience of home.

Before operating and using this toilet we advise you to read the manual completely. Keep this manual in a safe place for future reference.

For the latest version of the manual please visit [www.thetford-europe.com](http://www.thetford-europe.com)

### General

The C223-S/C223-CS uses the central water tank of the of the vehicle to flush. The C224-CW has an integrated flush - water tank with a flush handle.

The C223-CS features a flush button on the control panel.

The C224-CW features a flush handle on the console to flush the toilet.

The C223-S features a flush button on the control panel on the wall to flush the toilet.

A cassette toilet is not connected to a central sewage. This toilet has an integrated sewage system (B), which you need to empty when full.

### Main Parts

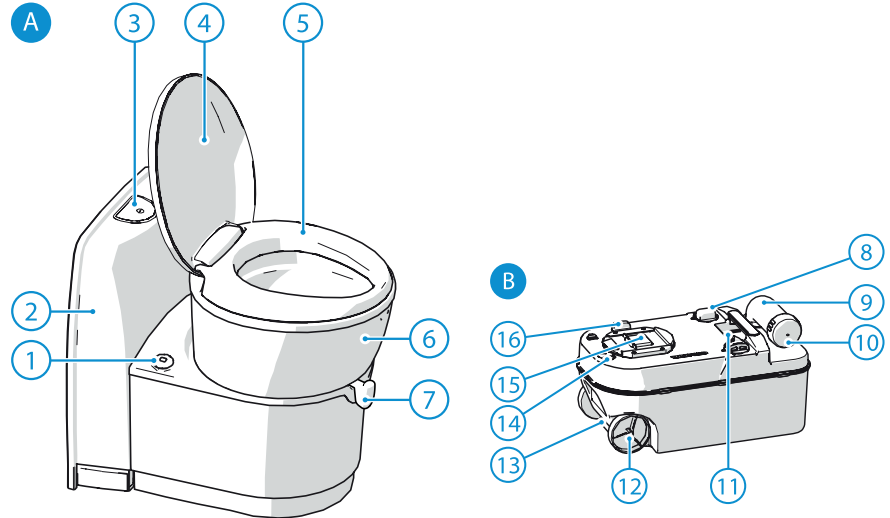

#### A. Toilet

1. Level indication
2. Console (C223-CS)  
Flush-water tank (9L) (C224-CW)
3. Control panel\*
4. Cover
5. Seat
6. Swivelling toilet bowl
7. Blade handle
8. Float

#### B. Waste holding tank (18L)

9. Pour out spout
10. Cap
11. Automatic pressure release vent
12. Wheel
13. Pull handle
14. Vent button
15. Sliding cover
16. Blade opener



## Before Use

Prepare the waste holding tank

- Remove the waste holding tank through the service door (01).
- Place the waste holding tank upright and turn the pour out spout upwards.
- Remove the cap from the pour out spout (02).
- Check the correct dosage of Thetford waste holding tank additive on the package.
- Add the stated dosage to the waste holding tank (03).
- Add  $\pm 3L$  of water to the waste holding tank to ensure that the bottom of the waste holding tank is covered (03).
- Screw the cap back onto the pour out spout.
- Slide the waste holding tank back into its original position via the service door (04).

Prepare the flush water tank (only for C224-CW)

- Check the correct dosage of Thetford flush water tank additive on the package.
- Add the stated dosage to the flush water tank through the waterfill door (05).
- Fill the flush water tank with clean water through the waterfill door, using a jerry can or hose (05).

## Preparing waste-holding tank

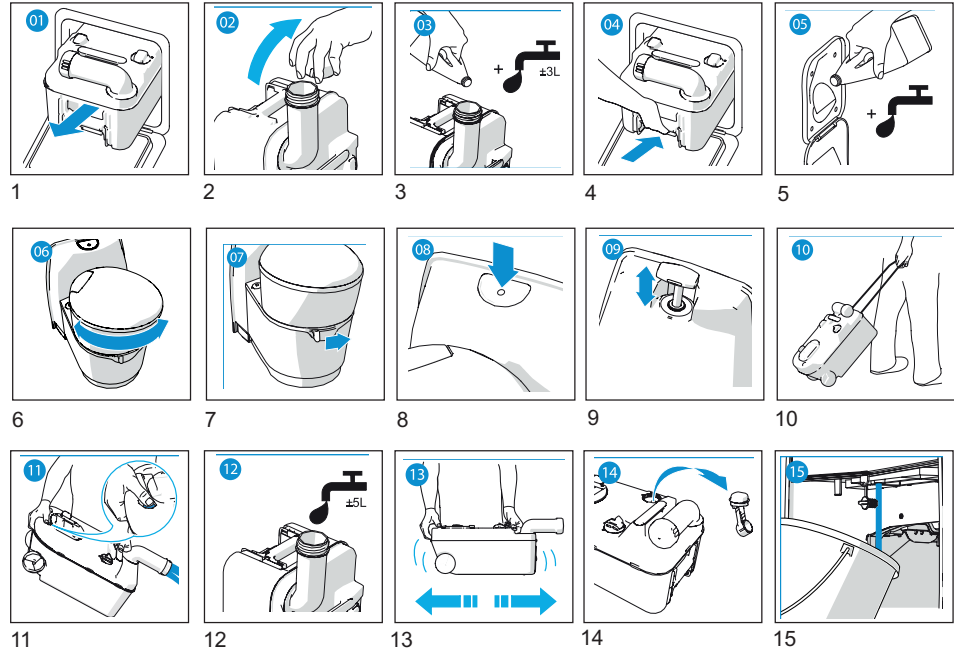

## WARNINGS:

**Never add toilet additives directly via the valve blade or via the toilet bowl as this could damage the lip seal of the waste holding tank. Only fill the waste holding tank via the pour out spout.**

**Never use force if you cannot get the waste holding tank back into place easily. If blockage occurs, always check if the blade handle is in the closed position.**



# THETFORD TOILETS

## Use of the toilet

Turning the toilet bowl:

- Close the cover and use both hands to rotate the bowl to the desired position (max 90° clockwise and 170° counterclockwise) (06).

## Opening the blade:

- Open the blade by moving the blade handle from left to right (07).
- Always close the blade completely after use.

The toilet can be used with the blade open or closed.

## Flushing the toilet

- Make sure the blade is open.

## For C223-S/C223-CS:

- Press the flush button and hold it for several seconds to flush the toilet (08).

## For C223-CW:

- Move the flush handle up and down to flush the toilet (09).
- Close the blade after flushing.

**Note:** Ordinary toilet paper can cause clogging. Use Thetford Aqua Soft toilet paper for your toilet. This toilet paper is super-soft, dissolves quickly, prevents clogging and makes it easier to empty the waste holding tank.

For C223-S/C223-CS: The flush of your toilet will be more effective if you pulsate the flush by pressing the flush button several times in a row.

## WARNINGS:

**To prevent water damage to your caravan or motorhome, do not travel with water in the toilet bowl.**

**Do not leave water in the toilet bowl if the toilet is not being used. This does not help to reduce unpleasant smells and only leads to flooding.**

## Emptying the waste holding tank

Your toilet has a 1-level indication for the waste holding tank. When the slide turns from green to red, the waste holding tank is full.

Emptying the waste:

- Remove the waste holding tank (01).
- Fold out the pull handle unit until it is fully extended.
- Pull the tank to an authorised waste disposal point (10).
- Place the waste holding tank upright and turn the pour out spout upwards.
- Remove the cap from the pour out spout (02).
- Press and hold the vent button with your thumb while the pour out spout is pointing downwards to empty the waste holding tank (11).
- Add ±5L of water to the waste holding tank and replace the cap (12).

- Gently shake the tank to clean it (13). Empty the waste holding tank again (11).
- Remove the float from the waste holding tank by turning it clockwise and rinse the float with tap water (14).
- Fold in the pull handle until it clicks into place.
- Slide the waste holding tank into the toilet and close the service door (04).

## Emptying the flush water tank (C224-CW)

Only empty the flush water tank completely if you expect not to use your toilet for a long period.

- Place a sufficiently large bowl under the drain tube.
- Open the drain tube and catch the remaining water in the bowl (15).
- Empty the bowl at an authorised waste disposal point.

**WARNING: To prevent water damage to your caravan or motorhome, do not travel with a flush water tank that is too full. Thetford advises travelling with an empty flush water tank, but at least not filled more than half full.**



## Maintenance and Cleaning

Thetford recommends cleaning your toilet regularly to prevent limescale and ensure optimal hygiene.

- Clean the inside of the bowl with Thetford Toilet Bowl Cleaner and a soft brush.
- Clean the outside of the bowl with Thetford Bathroom Cleaner.
- Remove the seat and cover to clean your toilet thoroughly. To do this, push the seat and cover together to the right, then lift them up.
- Remove the float from the waste holding tank and rinse it with tap water (04).

### WARNING:

**Never use household cleaners to clean your toilet. These may cause permanent damage to the seals and other toilet components.**

**Never use Vaseline or vegetable oil to lubricate the seals. This may cause leakage to your waste holding tank.**

**Note:** The blade seal is a part of the toilet that is subject to wear. Depending on the extent and manner of servicing, after a certain period the seal will lose quality and must be replaced.

### Winter Use

You can use your toilet as normal in cold weather as long as the toilet is situated in a heated location. Make sure you completely empty the waste holding tank if you do not use the toilet.

## Troubleshooting

Problem	Possible Cause	Solution
Waste holding tank cannot be removed	Blade is (partly) open	Fully close the blade
Blade does not move	Blade is blocked	Loosen cap from pour out spout
Level indication waste holding tank does not work	Mechanism level indication in waste holding tank is stuck	Remove mechanism from waste holding tank and rinse it with tap water
Waste holding tank leaks	Seal is dry Seal is worn	Spray seal with seal lubricant. Replace seal



## AWNING/ROOFLIGHTS

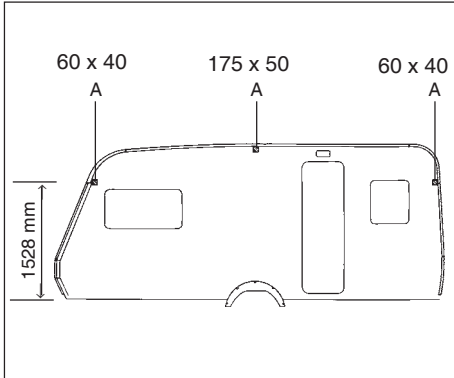

### AWNING FIXING POINTS

In all Venus Caravans fixing blocks for the awning brackets are now fitted as per the diagram (position A). The centre block is determined from centre of wheel arch and just below awning rail.

The end fixing points are just above window height front and rear, approximately 60mm long x 40mm, 1528mm above the underside of the floor (i.e. from top of skirt).

**Care must be taken when fixing the brackets and a suitable sealant used.**

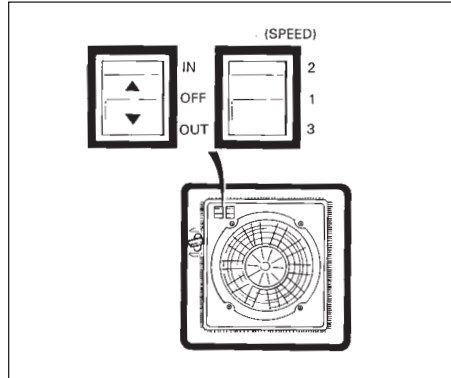

### 12 VOLT ROOF MOUNTED EXTRACTOR FAN

The fan is a double glazed rooflight. Its side operating mechanism allows a completely free central opening with built-in fixed ventilation when closed.

### TILT & SLIDE ROOFLIGHT

To open - turn the handles to release the rooflight. Push it upwards and slide it towards the front of the caravan.

Before travelling ensure the rooflight is in the fully closed and locked position.

A fully adjustable flyscreen and black out screen are built into the frame.





## STATUS TV ANTENNA

### OPERATING THE SYSTEM

#### Travelling

When positioning the Antenna Dome please allow for the following:-

#### DO NOT TRAVEL:-

- With the Antenna raised
- With the Antenna set for vertical signals

To reduce the possibility of damage when travelling, have the antenna pointing towards the rear of your caravan/motor home.

#### Operating

1. Loosen the Mast Locking Collar and raise the antenna.
2. Determine whether the TV transmissions are horizontal or vertical and position accordingly.
3. Switch On the Amplifier and the LED will illuminate and check the gain is set to MIN by rotating the button anti-clockwise.
4. Rotate the antenna.
  - RED - Poor signal - keep turning.
  - YELLOW - getting better - slow down.
  - GREEN - Signals located, ready to GO.
5. If there's no GREEN increase the Gain and repeat the 360 degree rotation.
6. Once the transmitter has been located increase the Gain to MAX.

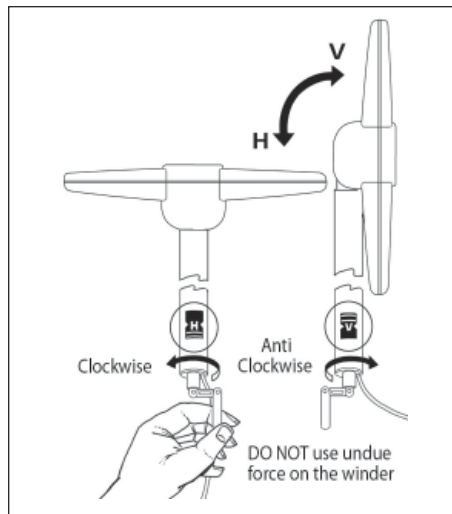

7. Turn on your television set and tune in. This will be necessary at all new locations.
8. Secure the Antenna by hand tightening the Mast Locking Collar.

#### IMPORTANT

You may detect more than one transmitter. Choose the position that gives you the most channels when tuning in your TV.

In poor signal areas the LED may only glow YELLOW.

In strong signal areas you may need to reduce the gain by rotating the Control anti-clockwise.

#### Removing the Antenna

A permanently fitted Status can be easily removed leaving only the Mounting Foot and rubber gaiter.

1. Unplug the antenna lead from the Amplifier.
2. Loosen the Mast Locking Collar and lift off whilst feeding out the mast, coaxial cable and plug.
3. Push the Blanking Cap supplied into place.

**IMPORTANT** - The Blanking Cap is a temporary seal and is not recommended for long term use.

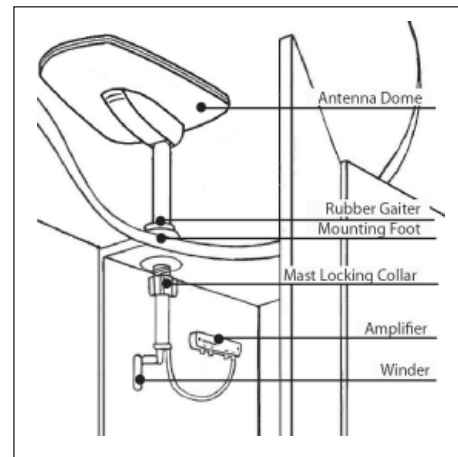



# ANTENNA

Signal	Symptom	Action
Very Poor	No picture or sound, TV freezing, severe pixilation, break up and picutre drop out	Check the amplifier gain is set to maximum (rotate clockwise). Check antenna alignment which must be directed at the transmitter. Ensure the antennas polarity is correct, whether horizontal or vertical. Bypass the amplifier by following "Short Hook-Up Test 1"
Poor	Moderate pixilation and sound distortion	
Medium	Minor pixilation will not receive all channels	
Good	Stable picture, good sound quality will receive all channels	N/A
Strong	Possible pixilation, picture break up and drop out.	Reduce the amplifier gain (rotate anti-clockwise). Rotate antenna AWAY from the transmitter.
Very Strong	No picture or sound, TV freezing, severe pixilation, break up and picture drop out.	Rotate antenna AWAY from transmitter. Switch 'OFF' the amplifier and turn the gain control to maximum (rotate clockwise).
<b>After performing any of the 'Actions' above you must re-tune your TV</b>		

## Guarantee

The Status Antenna has a return to base guarantee against defective parts and workmanship for two years or a period determined by the vehicle manufacturer. This does not include any malfunction resulting from improper use, incorrect installation, accidental or malicious damage. To support your guarantee claim a dated Proof of Purchase will be required.

This does not affect your statutory rights. Any queries concerning warranty please contact ourselves.

## Fault Finding

The following are some of the key areas we suggest you check which generally solve the most common problems encountered with the operation of the Status antenna.

### Coaxial Connections

It is critical that all connections in the system are fitted correctly and only quality plugs have been used.

### Coaxial Cable

Sharp bends, kinks and hot surfaces can easily damage coaxial cable and should be avoided. Coaxial cable, if placed in close proximity to electrical cables, transformers or other pieces of electrical equipment, may pick up electrical interference causing picture quality to deteriorate, especially in poor reception areas. Excess cable should be removed and NOT coiled as this may cause picture distortion. An inspection of the routing of the cable is highly recommended to ensure all is correct.

### Gain Control

In normal use the button should be rotated clockwise for maximum. In strong signal areas the amplification may need to be reduced. To reduce amplification rotate the button anti-clockwise until picture quality improves. The button rotates through 270 degrees from MAX to MIN.



## LED Light

Should the LED on the Amplifier not light, firstly check there is power to the unit. Secondly check the polarity is correct. Otherwise contact ourselves for further assistance.

### Short Hook Up - Test 1

This test isolates the wiring from the Amplifier through to your TV/Radio points.

Unplug the coaxial plugs from the 'TV' sockets of the Amplifier and using your TV fly lead with Converter 1 supplied. Connect your TV to the Amplifier.

Please ensure the Antenna Dome is plugged directly into the 'ANT-IN' socket of the Amplifier and switch on. Tune in your TV for the strongest signal.

If the picture quality improves the fault lies with the wiring of the system between the Amplifier and the TV outlet socket.

### Short Hook Up - Test 2

This test isolates the Amplifier by connecting your TV direct to the Antenna.

Unplug the Antenna from the Amplifier and connector Connector 2 supplied to the plug on the cable end. Using your TV flylead connect the antenna directly to your TV. Tune in your TV for the strongest signal.

If the picture quality improves the fault lies with the Vision Plus Amplifier.

## Antenna Dome Co-axial Cable

Check the routing of the coaxial cable from the Antenna Dome to the Amplifier. Check to ensure there are no kinks or trapped cable or if there are loops of surplus cable which could be affecting performance.

### Customer Help Line

Should you still be experiencing difficulties and require assistance, please do not hesitate to contact us at the address below.

## MAINTENANCE

### Gaiter

We suggest you periodically check the gaiter for any signs of damage or for wear.

If the rubber is caught by overhead obstructions it may rip or tear which would allow water to work its way into the fabric of the roof.

Over an extended period of time the gaiter will wear at the contact area with the mast. Should the gaiter begin to fail the signs will be small amounts of water dripping down the outside of the mast, however, the design of the Gaiter and Mounting Foot ensures that water cannot work its way into the fabric of the roof. Should this problem occur contact ourselves for a replacement unit.

## Spares & Repairs

Should you require any parts for replacements or repair please log on to [www.gradeuk.co.uk](http://www.gradeuk.co.uk) or contact ourselves on 0115 986 7151.

### Vision Plus

8 Finch Close  
Lenton Lane  
Nottingham  
NG7 2NN  
0115 986 7151  
[info@visionplus.co.uk](mailto:info@visionplus.co.uk)  
[www.visionplus.co.uk](http://www.visionplus.co.uk)



## LIGHTS, CD/RADIO/MP3

---

### **LED LIGHTING**

LED lighting is non replaceable.

### **CD/RADIO/MP3 PLAYER**

Your caravan is fitted with a Pioneer CD/ Radio unit. Please refer to manufacturers manual for further functionality & instructions.

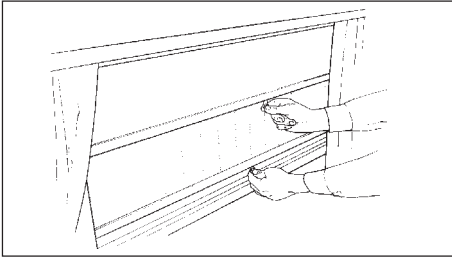

## FLYSCREENS AND SUNBLINDS

**Important:** Blinds should be checked for holes and tears when you take delivery of your caravan. Failure to report a fault at this stage will result in a claim under warranty being rejected.

## OPERATING INSTRUCTIONS

### Flyscreen

Pull the flyscreen fully down and gently push the crossbar towards the window so that it locates in the retaining “cut out” within the rear channel of the lateral guides. To release, gently pull the crossbar downwards and toward you and allow the tension of the spring mechanism to rewind the flyscreen upwards.

**DO NOT RELEASE THE HANDLE** – causing the flyscreen to “whiplash” upwards – as this will cause damage to the spring mechanism.

### Sunscreen

The front channel of the lateral guides has a number of “cut outs” to enable the sunscreen to be retained at various heights – look inside the lateral guides to locate these. To raise or lower the sunscreen follow similar procedure as with the flyscreen.

### TENSION ADJUSTMENT

The tension adjustment clips are located at the left side of the cassette – the top one is for the flyscreen and the lower one for the sunscreen.

Insert screwdriver into tension clip, apply gentle inward pressure and rotate tension clip one or two clockwise turns to increase tension or anti-clockwise to reduce tension. Gently release the inward pressure to enable tension clip to re-engage into its internal ratchet. Check tension and, if necessary, repeat until the crossbars return to their top positions without too much tension or assistance. **DO NOT OVERTENSION.**

**Note: It is not recommended that the window blinds are retained in the “down” position whilst the caravan is being towed.**

### WINTERISATION

The flyscreen/sunscreen should NOT be left in the “down” position through the winter as this may cause the spring mechanism to lose tension.

However to rectify this, gently pull crossbar downwards and toward you then allow the tension remaining in the mechanism to rewind, when it stops pull the crossbar downwards and upwards five or six times to restore correct tension.

Should the blinds not retract fully, please follow Tension Adjustment instructions.

### DOOR FLYSCREEN

The flyscreen runs in a bespoke cassette housing with inbuilt track.

To Open/Close from inside or outside pull the handle that runs the entire length of the screen across to the desired position.

### 3. Cleaning

Use a damp cloth and, if necessary, a normal household cleaner without abrasives or solvents.



## WINDOWS AND BODY

### WINDOWS

The windows on your caravan are made from acrylic. If you consider the instructions below, the windows will stay in good shape for a long time. Windows also require periodic maintenance and checking by your dealer at least once per year.

#### Operation



When the vehicle is in motion all windows must be fully closed.



Never use the blinds in direct sunlight. If you use the blind in direct sunlight, even for a short period, heat will accumulate between the window and blind possibly causing damage to the window such as bending/ballooning.

Your windows are equipped with either handles with buttons or handles with stays. Please observe the following operating instructions.

**Handles with buttons** - Always push the button when opening/closing the handle.

**Stays in step version** - You will hear clicks when opening the window. Every click represents the position in which a window can stay opened. When closing the window, you must open it till the end and then close. Do not try to close it without first opening it as wide as it goes, as this will damage the stays.

**Stays with knob screw** - Always make sure to unscrew the knob before closing the window.

**Catches** - The catchers enable three positions of the window. The open position is where the handle is open placed on the outer part of the catcher. If the handle is placed in the middle of the catch, this is the position for ventilating. The closed position is where the handle is closed on the inner part of the catch.

#### Cleaning

##### 1. Cleaning window profiles

To clean coloured and anodized profiles, use a soft cloth and water without any aggressive cleaning solvents. The use of any chemicals and abrasive cleaners could damage the surface of the profile.

##### 2. Cleaning windows

Never use abrasive or corrosive substances or solvents on windows, such as turpentine, spirit or dishwasher detergents, as they will damage the acrylic and/or print. We recommend cleaning with a generous amount of water or mild cleaner intended for use on acrylic. There are some specialist plastic cleaning agents such as Plexus or Brilliance which can be used if preferred. Cleaning with a dry cloth can damage the acrylic and leave scratches; always use a

moist sponge or moist soft cloth. Never clean windows with a high pressure washer. Please also note that a carwash can cause scratches or other damages.

**Acrylic material can get scratched very easily. Please consider the above instructions for cleaning, so that you will not cause scratches or other damages.**

#### Temporary Condensation

Condensation can appear on the window or between both panes. This is a normal occurrence that appears because of different temperatures inside and outside, moisture and the properties of acrylic itself. Condensation will disperse after some time. This doesn't mean that there is something wrong with the window or that it is leaking. With a properly ventilated vehicle you can in most cases prevent condensation.

#### How to overcome condensation

##### 1. Improve ventilation

- (a) Leave rooflight open or use a self-ventilating rooflight.
- (b) Add to the ventilation by fitting more improved ventilators.
- (c) Put windows onto night vent position.
- (d) Leave doors open between compartments.



## 2. Help yourself tips

- (a) Do not wash crockery last thing at night, it creates more moisture in the air.
- (b) Do not boil water last thing at night and empty all water from kettles, etc.
- (c) Remove flowers or vases containing water from sleeping quarters.
- (d) Keep temperature at night to a minimum (hot air contains water vapour).
- (e) Increase ventilation to above normal in inclement or very wet weather.

**Note: You cannot expect to eliminate condensation completely but following the hints above will help towards a more comfortable environment.**



## ABS PANELS

---

### CLEANING THE CARAVAN BODY

It is wise to wash the caravan body regularly in order to maintain its good looks. Do not use aggressive cleaning materials as this will damage the paintwork over time. 'T Cut' or other similar cleaning compounds should only be used occasionally for stubborn marks. We suggest that a good quality car wax, applied at least once a year, will enhance the paintwork and ease the cleaning operation.

### ABS Panels

ABS components need to be washed, waxed and taken care of like a car. Most stains or marks can be removed with mild detergent, but more stubborn marks may require a (fine grit) rubbing compound such as T-cut.

To help keep your ABS components looking almost like new, it is wise to wash the parts monthly (or more frequently) using mild detergent, but avoid using strong alkaline (e.g. tri-sodium phosphate) or acidic cleaners or abrasives. Waxing the components once or twice a year with a good grade paste wax will help to maintain the colour and finish.

### BADGES

Resin coated badges are now being widely used within the caravan industry. Their upkeep is simple, use soap and water only to clean them. Under no circumstances should abrasive cleaners or solvent based solutions be used on them.





## BUNK BED ASSEMBLY

The following step by step guide illustrates how to assemble the bunk bed.

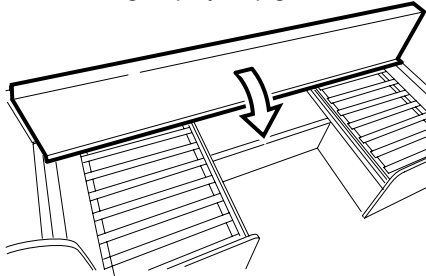

1. Pull the top edge of the bunk towards you.

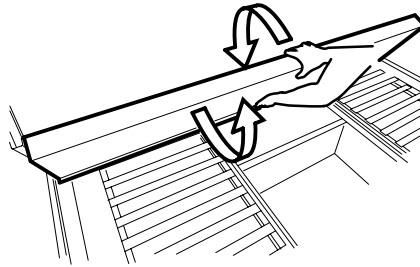

2 & 3. With your left hand on the bottom edge, lift upwards and towards you, while your right hand keeps the bunk steady.

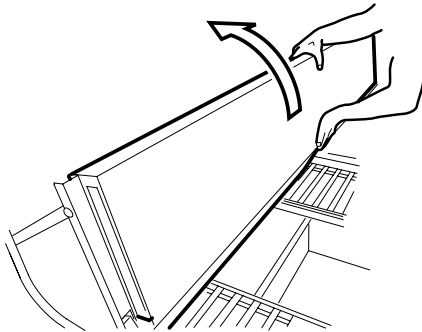
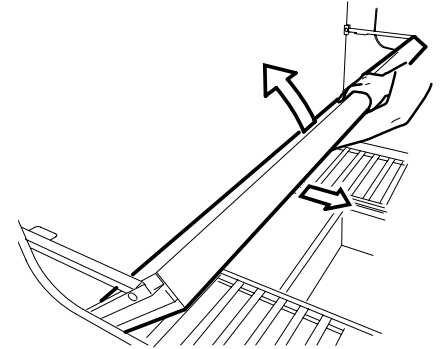

4 & 5. As the left hand passes the pivot point allow the right hand to slowly lower the bunk into the rest position.

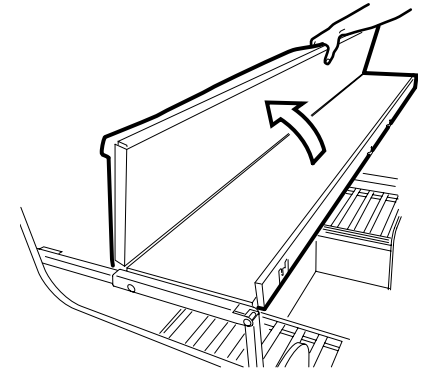
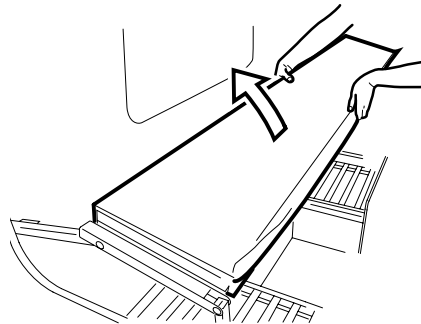

6. Fold the two part bunk into position.



## BUNK BEDS

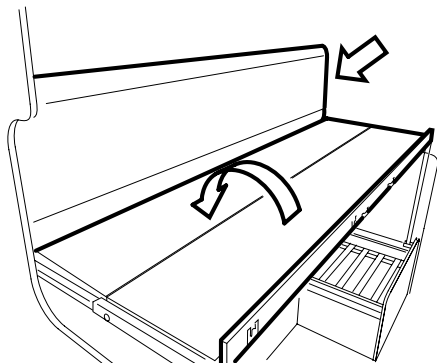

7. Fit the safety boards into position.

### FRONT BEDS

To make the front beds up into a double bed, lift the front edge of the bed frame slightly in the centre (just enough to clear the carpet but not to collide with the bedside cabinet) then pull the bed frame edge towards the centre of the vehicle. The back rests will then drop into the void to make up the bedding.

To convert the bed back to side seats, reverse the operation above.

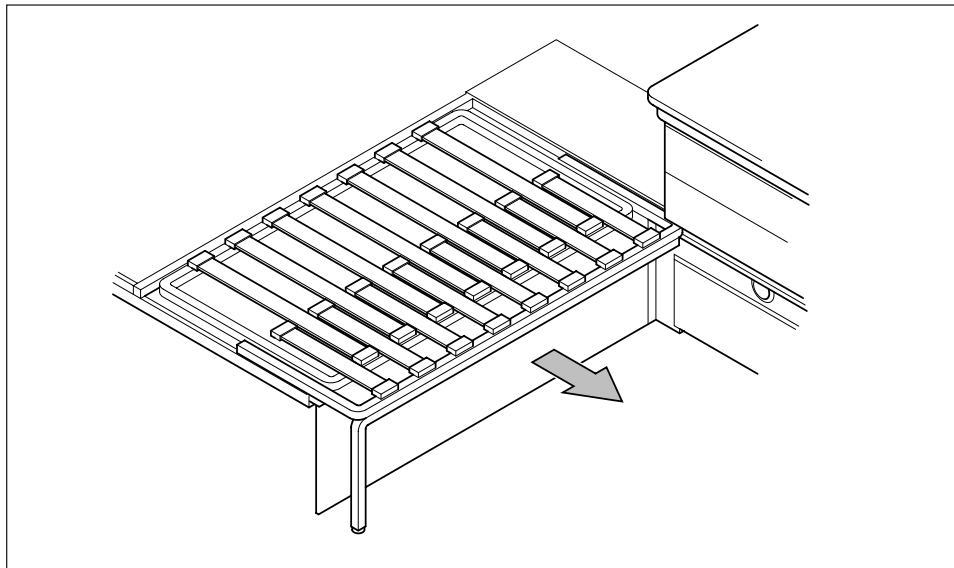

# HOW TO MAINTAIN FURNITURE IN A CARAVAN



## HOW TO PROPERLY MAINTAIN THE FURNITURE IN A CARAVAN

### About Humidity

Air contains moisture – this is called humidity. The higher the temperature of the air the more water it is able to hold. Air at 20°C can hold a lot more moisture than air at 10°C. The term 'relative humidity' describes how much moisture air contains at a given temperature. 100% relative humidity means the air is holding as much moisture as it can at that temperature.

The more humid the air is in your caravan, the more energy it takes to warm your van because it is also warming the water in the air. This means it will be more expensive to heat!

A good range of indoor humidity for comfort and health is between 30-60% during cooler months of the year. Mould is likely to occur if the relative humidity indoors is 70% or more for long periods of time. Keeping humidity levels under 50% also helps to minimise or control dust mites.

It can be fun to buy a low cost humidity meter from a hardware store and track how humid the air in your caravan is. You might be surprised at how quickly it can change, from morning to night and as the weather changes.

### About Condensation

When the humidity is high inside a van and it is cold outside the water vapour condenses on cold surfaces. What causes dampness and condensation in your van?

- Lack of adequate ventilation and/or heating.
- Water coming in from the outside through leakage, seepage or open windows
- High levels of moisture/water vapour being produced inside the caravan

Humid air and condensation can also be generated by things people do on a daily basis.

- Cooking Up to 3 litres per day
- Showers and baths 1.5 litres per person
- Washing dishes Up to 1 litres per day
- Unflued gas heater 0.5-1.0 litre per hour of use
- Breathing, active adult 0.2 litres an hour per person
- Breathing, adult asleep 0.02 litres an hour per person

Because your Furniture pieces are made from wood or wooden materials they require attention and care to maintain their beauty over time.

Moisture in air can cause damage to furniture. Wood expands or contracts with an increase or decrease in the relative humidity in the air. A 40% -60% relative humidity is tolerable. Beyond this level, wood can expand. The damages can be quite visible if the relative humidity is higher than 80% for a long time. To prevent damage, assure the relative humidity of air is not too high for a long time by ventilating the van, using dehumidifiers or water absorbent substances.

When wood is wet, wipe it dry. Do not just wait for the sun to dry it. The longer the water stays on the surface, the more damage it can do.

How to keep your caravan dry and avoid condensation

There are lots of things YOU can do to minimise dampness and condensation in your caravan.

### The key actions:

- Provide ventilation and/or reduce relative humidity of air by, particularly in moisture-prone periods of year (especially winter time) and when the moisture is produced in the van (cooking, shower)
- Reduce the amount of moisture produced in the van
- Increase heating to raise the temperature of the air and the cold surfaces



## HOW TO MAINTAIN FURNITURE IN A CARAVAN

---

On dry days open some windows to allow humid air to ventilate out of the van. It is better to open a few windows a little throughout the whole caravan. This helps the air to move through the caravan. One window open wide may not be as effective. Try to do this as often as possible (at least once a week), but keep windows closed on wet days as damp air may increase indoor humidity.

High temperature can also damage the surfaces of your furniture. Protect them with protective table pads or place-mats when utilizing extremely hot utensils or dishes.

### **Do Not's**

- use detergents or chemical cleaners on your furniture this may damage the finish,
- drop the pieces,
- expose the furniture to extreme hot, cold, rain, humidity or salinity,
- leave surfaces wet with beads of water standing

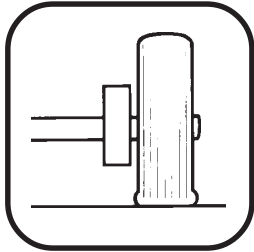

# AL-KO CHASSIS & TYRES

Chassis .....	102
Tyres .....	103



## AL-KO CHASSIS & TYRES

All caravans are released with a hard copy of the latest Al-Ko chassis handbook, please retain this and store it along with your Lunar Handbook and refer to it for issues relating to the chassis operation and maintenance.

For advice relating to:

Chassis

Running Gear

Braking System

General Maintenance

The latest version can also be found online at: [www.al-ko.co.uk/pages/original-2.html](http://www.al-ko.co.uk/pages/original-2.html)

Clubman and Delta models will also feature as standard a premium AAA Braking system. See [www.al-ko.co.uk/pages/aaa-al-ko-automatic-adjustment-2.html](http://www.al-ko.co.uk/pages/aaa-al-ko-automatic-adjustment-2.html)



### CARAVAN CHASSIS

HANDBOOK FOR VEHICLES ON  
THE AL-KO CARAVAN CHASSIS



## GENERAL NOTES ON MAINTENANCE

### Tyre Wear and Damage

The legal requirements for tread depth on motor vehicles apply also to caravans. In order to equalise wear it is suggested that wheels be balanced and changed around from time to time.

It is dangerous to neglect tyre damage and should you detect a blister, rupture or cut exposing the casing, or if it has suffered a violent impact (for example against a kerb), such that there is a risk of internal damage, it is advisable to have it examined by a tyre specialist as soon as possible.

### Wheels

The condition of wheels should be checked regularly particularly for distortion of flanges and the wheel dish. Wheels damaged or distorted, or having wheel bolt seatings cracked or deformed must not be repaired.

### Couplings

1. Clean and grease spherical seat, bearing parts and pivot pins regularly.
2. Thoroughly examine all moving parts for wear and correct functioning.
3. Couplings should never be drilled.

### Towing Ball

The automobile towing ball should measure 50mm maximum and 49.5mm minimum (DIN 74058). If the ball is found to be worn it should be replaced immediately.

### Overrunning Device

The device housing is packed with grease on assembly, but will require periodic maintenance to ensure smooth operation of the braking system.

1. Regrease the shaft bearings via the grease nipples provided at 3000 mile intervals and before storage.
2. Ensure correct functioning of all pivot pins and levers and oil regularly.

### Jockey Wheel

Lubricate wheel and screw thread periodically.

### Brake Linkage

All moving parts should be lubricated periodically to ensure their satisfactory operation.

It is recommended that all brake linkage threads are liberally smeared with grease for protection and as an aid to future adjustment of the system.

### Corner Steadies

The screw and pivot pins should be lubricated periodically to ensure their satisfactory operation.

### Braking System

At 500 miles then every 3000 miles or 1 year check and adjust brake linkage to compensate for any stretch of the bowden cables.

Check and adjust wheel brakes to compensate for wear.

**IMPORTANT:** When replacing the wheels you should tighten the nuts in rotation diagonally, taking care to tighten them equally.

**Please see Preparing for Road Page 11 for torque settings.**

### IMPORTANT NOTICE:

The caravan is manufactured for towing behind road cars and the 4 x 4 "off road" type of passenger car derivative. **THE CARAVAN IS NOT SUITABLE FOR TOWING BEHIND COMMERCIAL VEHICLES.**



# AL-KO CHASSIS & TYRES

## TYRES

### PREPARATION

#### Tyres & Tyre Pressure

Safe driving and handling when towing a caravan is very important and one major factor which is frequently overlooked is the tyres. Look after your tyres properly and you will improve the safety and behaviour of your car and caravan.

#### Check the Pressures

Whatever tyres are fitted to the towing car and caravan it is essential to the safety and stability of the combination that all tyres are correctly inflated. This is a 'golden rule' of motoring and of caravanning in particular.

Pressures should be checked when the tyres are cold, not warm during or just after a run when they will be higher. Never reduce pressures when tyres are warm as they could be too low when they cool down.

The tyres specified by the caravan manufacturer are satisfactory for towing in the UK and are rated up to 80mph (130kph) at the maximum design weight of the caravan. In certain countries overseas it is legal to tow at higher speeds. If it is intended to visit such countries and tow up to the higher speed limits then it is important that the suitability of the tyres is first checked with a caravan dealer.

#### Tyres & Pressures

The tyres fitted, and the pressures needed, vary from model to model. Check the Service Handbook for specific recommendations for your model.

The speed limit for towing a caravan in the U.K. is 60mph. If a tyre needs to be replaced you must ensure that you refit a tyre of the same specification. The correct pressure for your car tyres will be found in the car handbook.

#### Fit the Right Tyres

As with all road vehicles it is always advisable to have the same type of tyres on all wheels i.e. both on the towing vehicle and the caravan but it is recognised that caravans and trailers will frequently have a different type from the towing vehicle.

If a wheel or tyre has been changed the replacement has to be of the same type of construction and size as on the other wheels.

#### General Recommendations

Because caravan tyres and wheels are rarely the same as those on your car you must not attempt to use the car wheel on your caravan if you should have a puncture.

Check your tyres regularly but particularly when the caravan has not been used for a long time. Vehicles such as caravans if not used in the winter should be thoroughly inspected prior to re-use during the summer months. Look particularly for any signs of age deterioration in the tyres such as sidewall cracking and carcass deformation. Tyres on a stationary vehicle, particularly if parked in coastal areas, always age and crack more quickly than those which are run frequently and, if your caravan is going to stand for a long time it is a good idea to cover the tyres with old sacks, etc. to shield them from direct light and, if possible, to jack the weight off the tyres. If in doubt at all about your tyres have them checked immediately by a tyre distributor.

**WARNING: Prior to any journey the condition of the tyres should be inspected. The NCC recommend that tyres are replaced seven years from date of manufacture at the very latest.**



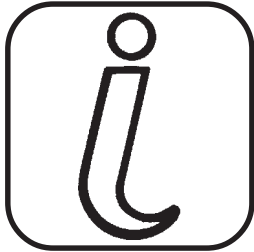

# GENERAL DATA

Wiring Diagrams .....	106
Light Bulb Replacements .....	113
Security .....	113
Owners Club .....	114
Owners Warranty .....	114
Winterization Guide .....	116



# GENERAL DATA

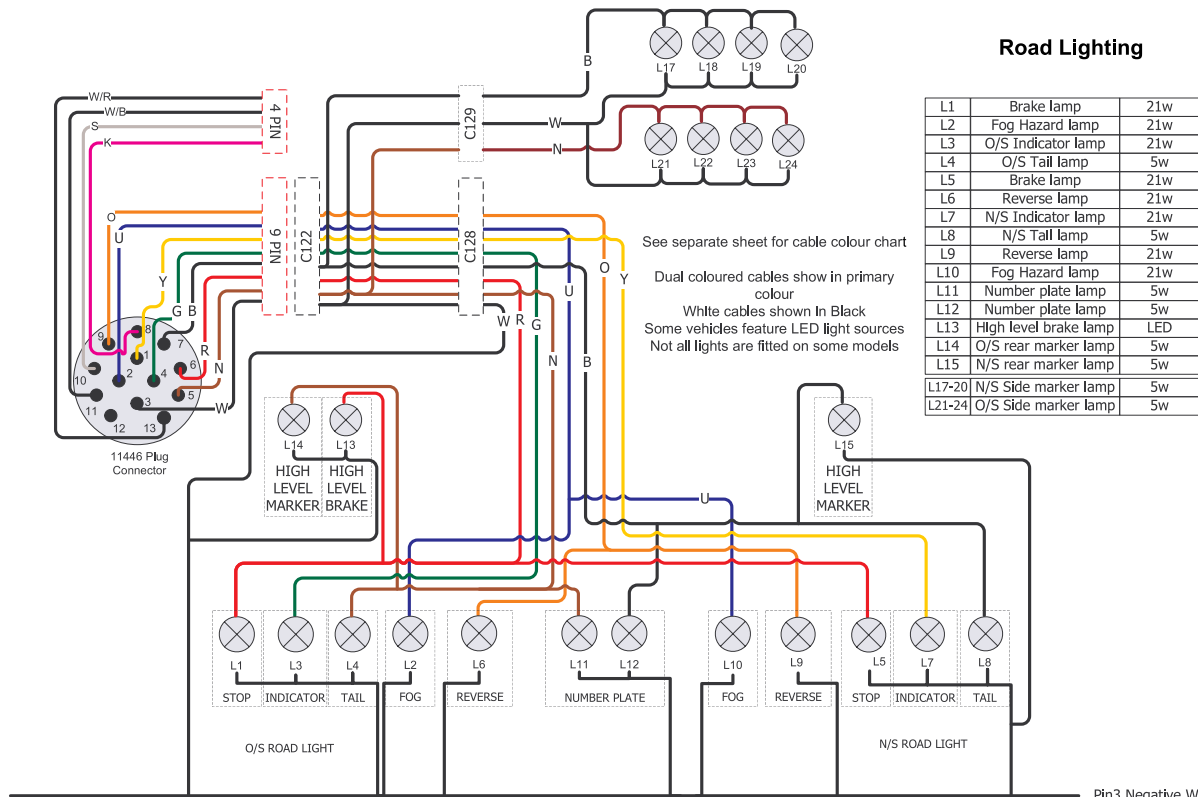

## Road Lighting

L1	Brake lamp	21w
L2	Fog Hazard lamp	21w
L3	O/S Indicator lamp	21w
L4	O/S Tail lamp	5w
L5	Brake lamp	21w
L6	Reverse lamp	21w
L7	N/S Indicator lamp	21w
L8	N/S Tail lamp	5w
L9	Reverse lamp	21w
L10	Fog Hazard lamp	21w
L11	Number plate lamp	5w
L12	Number plate lamp	5w
L13	High level brake lamp	LED
L14	O/S rear marker lamp	5w
L15	N/S rear marker lamp	5w
L17-20	N/S Side marker lamp	5w
L21-24	O/S Side marker lamp	5w

Pin3 Negative W

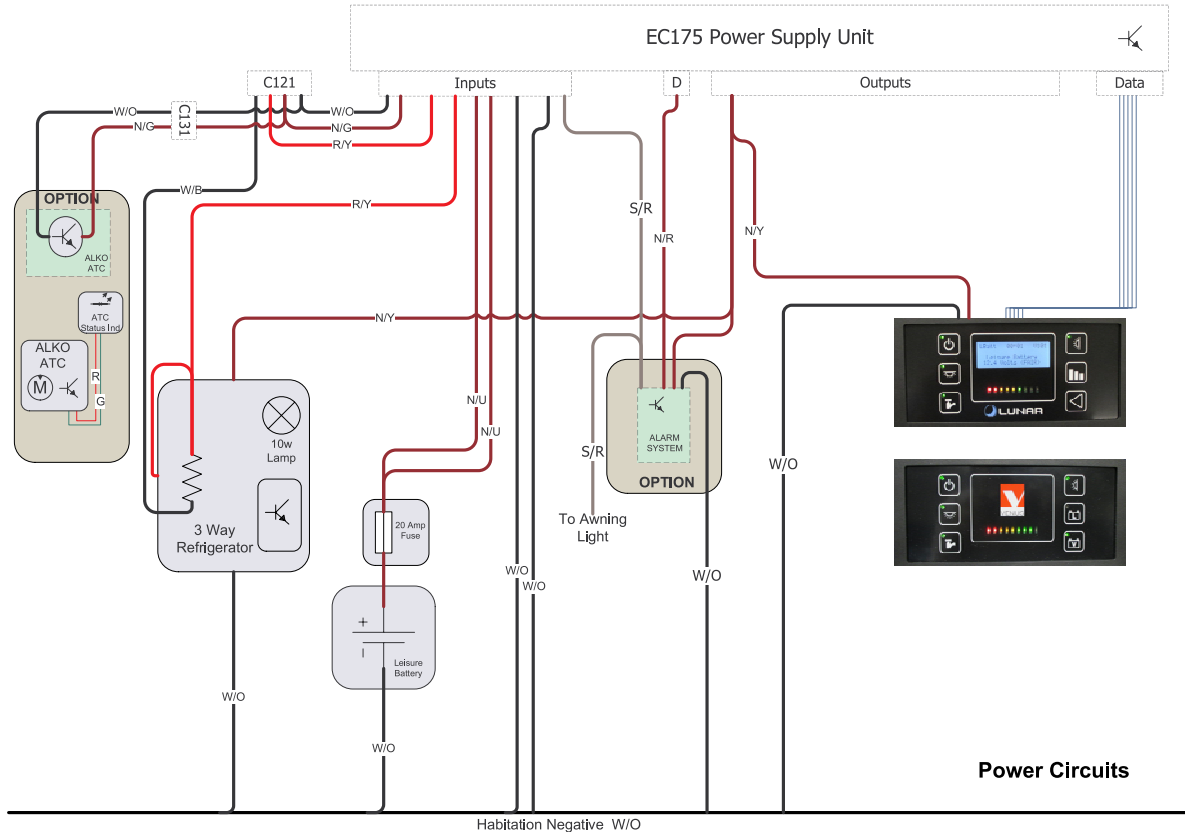

**Power Circuits**



# GENERAL DATA

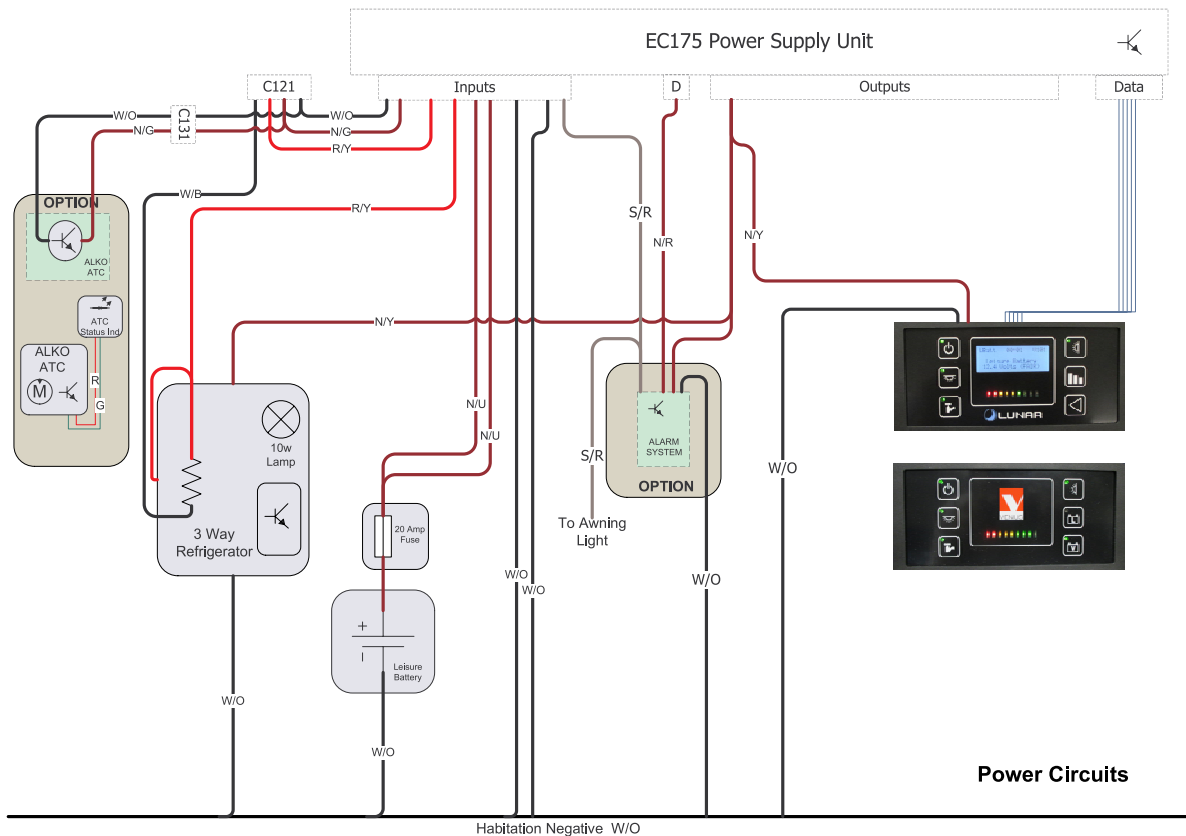

Power Circuits

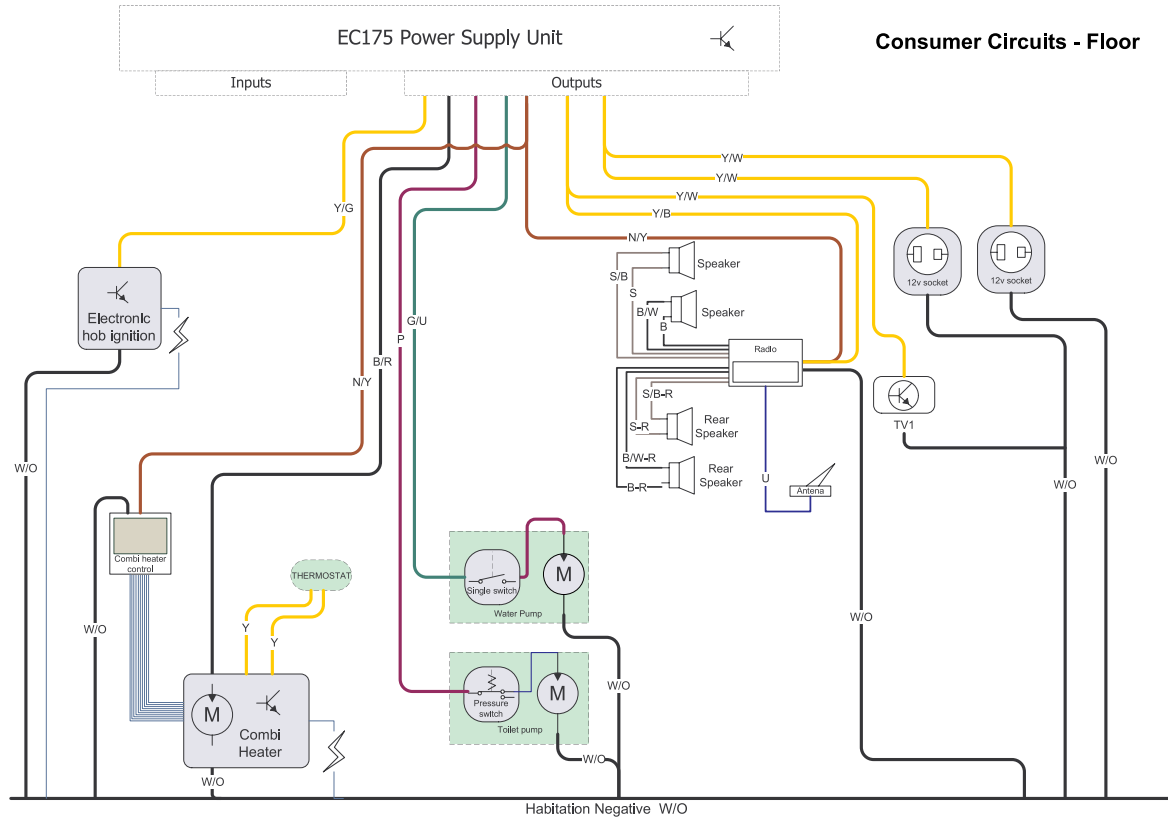



# GENERAL DATA

## EC175 Power Supply Unit

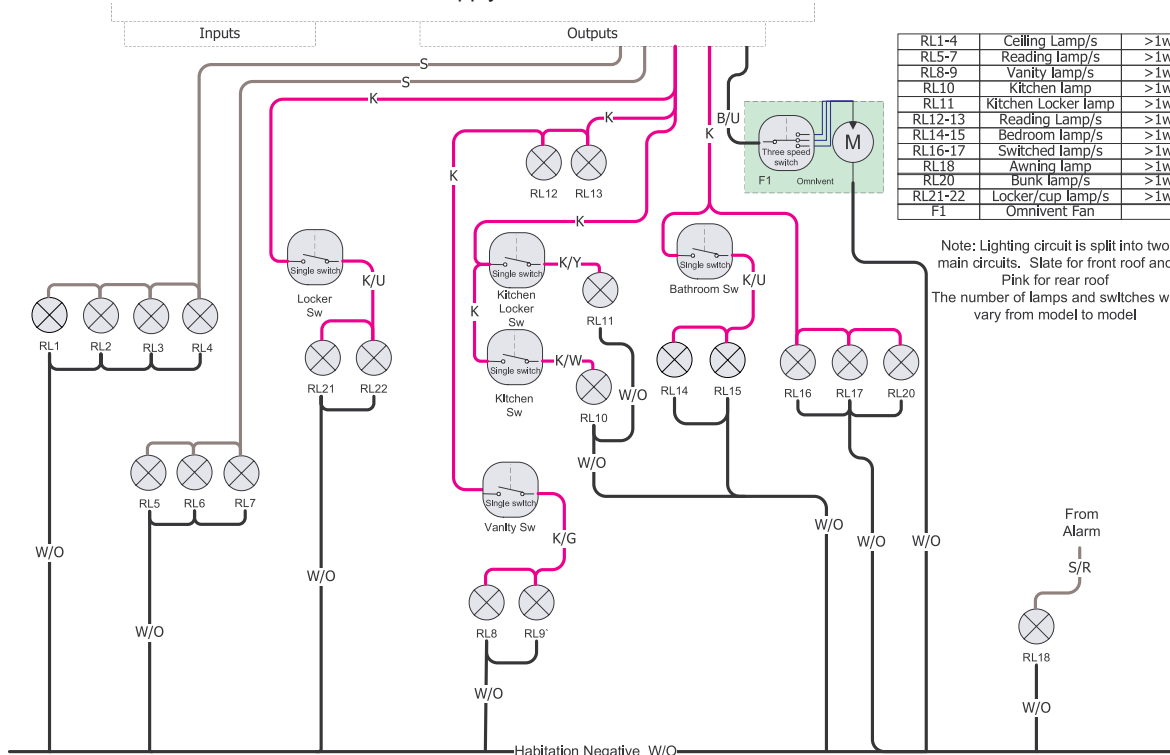

## Consumer Circuits - Roof

RL1-4	Ceiling Lamp/s	>1w
RL5-7	Reading lamp/s	>1w
RL8-9	Vanity lamp/s	>1w
RL10	Kitchen lamp	>1w
RL11	Kitchen Locker lamp	>1w
RL12-13	Reading Lamp/s	>1w
RL14-15	Bedroom lamp/s	>1w
RL16-17	Switched lamp/s	>1w
RL18	Awning lamp	>1w
RL20	Bunk lamp/s	>1w
RL21-22	Locker/cup lamp/s	>1w
F1	Omnivent Fan	>1w

Note: Lighting circuit is split into two main circuits. Slate for front roof and Pink for rear roof  
The number of lamps and switches will vary from model to model

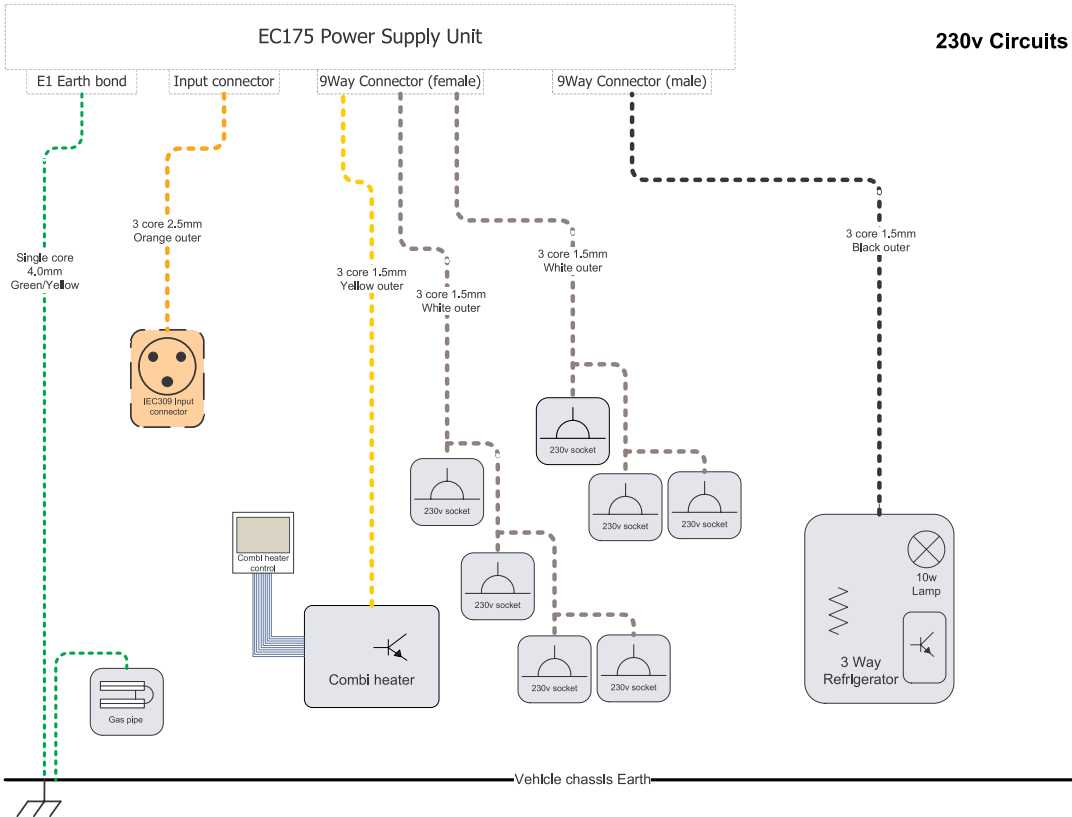



## GENERAL DATA



Y/U

Example

Yellow cable with Blue stripe

Cable Colour Chart

12v Cable Colours

<b>B</b>	BLACK
<b>N</b>	BROWN
<b>R</b>	RED
<b>O</b>	ORANGE
<b>Y</b>	YELLOW
<b>G</b>	GREEN
<b>U</b>	BLUE
<b>P</b>	PURPLE
<b>S</b>	SLATE GREY
<b>W</b>	WHITE
<b>K</b>	PINK

230v Cable Colours

<b>B</b>	BLACK
<b>N</b>	BROWN
<b>W</b>	WHITE
<b>O</b>	ORANGE
<b>Y</b>	YELLOW
<b>G</b>	GREEN
<b>U</b>	BLUE





## LIGHT BULB REPLACEMENT

Brake/side light .....	Twin 21W/5W, 12V
Front side light .....	5W, 12V
Side light (white/red) .....	5W, 12V
Indicator light .....	21W, 12V
Reversing light .....	21W, 12V
Fog light .....	21W, 12V
High level brake light .....	12V LED
Number plate light .....	5W, 12V
Mains Reading Light .....	10W, 12V Halogen
Ceiling Light .....	10W, 12V Halogen
Toilet ceiling light .....	10W, 12V Halogen
Awning Light .....	12V LED Strip (None replaceable bulb)
Spot light .....	10W, 12V Halogen
Front interior corner light .....	10W, 12V Halogen

**Note:** Where non replaceable bulb is stated this may refer to a LED strip or housed/encased bulb that cannot easily be accessed or replaced with a single bulb, the above is intended as a guide only, where replacements are required please refer to your dealer for advice on the best possible replacement procedure for the light fitting that requires replacing.

## SECURITY

Ensure that you lock all windows and doors when leaving your caravan. Fit a towbar hitch lock or a wheel clamp -consult your dealer on all safety and security recommendations.

Keep your gas cylinder locked when leaving your caravan.

Many devices are available to alarm your caravan. It is a good idea to mark your caravan in a secret place -this will help the police to identify it should it be stolen.

Caravans can be stolen from storage compounds, motorway service areas and even your own premises, so it is always wise to be vigilant at all times. Ask your dealer about details on all security aspects.



## GENERAL DATA

### LUNAR OWNERS CLUB

Now you are the owner of a Lunar caravan why not join the Lunar Owners Club.

This is an independent club run and organised by owners.

Lots of opportunities exist to make new friends at social gatherings and Rallies both Regional and National.

A leaflet regarding the Owners Club is within the wallet, if it is not please contact Lunar and a copy will be sent to you.

Alternatively for further information please visit the Lunars Owners Club website at: [www.lunarsownersclub.net](http://www.lunarsownersclub.net)

### OWNERS WARRANTY

All Lunar Caravans are supplied with a 6 year body shell warranty and a 3 year manufacturer's backed warranty from the date of purchase. The warranty is conditional on annual servicing being carried out within 60 days either side of the anniversary of the purchase date, except the third service which should be carried out prior to the third anniversary date of the final year.

#### Validating your warranty

Your Lunar warranty commences on the day your new caravan is purchased. It is important that as an owner you complete the "Validate your Warranty" section located on our website. This activates your Lunar warranty <http://www.lunarcaravans.com/validate-you-warranty>.

By registering your details we will be able to assist you more easily should you make a warranty claim.

Before you register please make a note of your caravan's 17 digit VIN number and you 3 digit Registration Security Number.

The VIN number, beginning SGL, can be found on the windows. The Registration Security Number can be found on the Model Label located inside your fridge or oven. The Model Label has a Serial Number or SER.NO and the last 3 digits of this number will form your Registration Security Number.

Please note that your oven and fridge will have different Serial Numbers to each other, but you can use the last three digits from either one to register your van.

Once your detail have been submitted you will be sent an email confirmation that you details and the above numbers have been successfully received.

#### Additional equipment

If additional equipment (other than those on the optional list of Lunar) is to be fitted you should check with your dealer beforehand. The warranty may be invalidated.

#### Vermin

Vermin can gain access via the smallest of holes. Lunar fit grills and grommets to prevent this but the nature of some caravan storage means it can happen with upsetting results. We advise setting a trap and/or poison and regular inspection

Vermin damage is not covered by warranty.



## CRiS

### Caravan Registration

This caravan has been security marked and recorded under the Caravan Registration and Identification Scheme that is recognised by the Caravan Industry.

Shortly after purchasing this caravan you should receive your Touring Caravan Registration Document. It will be sent by post to your home address.

Your Touring Caravan Registration Document will include a 17 character VIN (Vehicle Identification Number) shown in the top right hand corner. This 17 character will be permanently marked onto the caravan chassis.

To protect yourself and your touring caravan, never leave the Registration Document in the caravan. For security reasons keep it in a safe place.

If you sell the caravan please follow the instructions on the Touring Caravan Registration Document.

If you do not receive a Touring Caravan Registration Document, lose it, or any of the details recorded are incorrect, please contact: CRiS, Avonbridge House, Bath Road, Chippenham, Wiltshire, SN15 2BB or Tel: 0203 282 1000.

### VIN Chip Caravan Identification

The caravan's unique 17 character VIN will be incorporated into VIN Chip tamper evident labels; the master VIN Chip label is situated on the front near side window to aid police checking, another in the gas locker and a maximum of 10 placed on the inside of all windows (with the exception of opaque windows).

Three electronic RFID chips containing the individual identity of your caravan are concealed within the caravan and can only be read by using a specially programmed RFID scanner.

Your local police can obtain the use of a CRiS VIN Chip scanner by contacting CRiS on Tel: 0203 282 1000.



## GENERAL DATA

### CARAVAN WINTERIZATION GUIDE

If the caravan is to be stored for any length of time, the following procedure is advisable:

#### 1. Location

If possible avoid siting the caravan beneath trees or near dilapidated buildings, where strong winds may dislodge branches or slates that can damage the caravan. In exposed conditions ground anchors may be advisable. Be wary of low lying areas that may be prone to flooding.

#### 2. Covers

Large polythene or tarpaulin sheets should not, in the opinion of most experts, be used to 'seal' the caravan against the elements. Condensation and mould growth may be encouraged and any flapping material or guy ropes could scratch acrylic windows.

If you feel a cover is absolutely necessary because of where the caravan is parked, however, purchase one that is made of "breathable" material.

#### 3. Ventilation

Caravan vents should be left uncovered to provide adequate air circulation inside the caravan; however if in an exposed or salty location the vents on the side of the prevailing wind and/or the 'fridge vent may be closed off for the winter. If you have

regular access to the caravan, you could place some moisture absorbing crystals in cupboard corners to reduce the risk of condensation, but these will require fairly frequent changing.

#### 4. Interior

To prevent possible mould growth over the winter, clean and vacuum carpets, curtains and upholstery and if possible remove the soft furnishings and store in a warm, dry place (eg attic). If not possible to remove the cushions, store on edge away from the caravan walls, allowing air to circulate around them and cover with an old sheet to prevent fading in the sunlight.

Walls and ceilings should be wiped over with a mild anti-bacterial solution (eg Dettol) and can be polished afterwards if desired. Cupboards should be emptied, cleaned and vacuumed out. Small doors can be left ajar to assist ventilation, but larger doors should be closed or they may warp.

The refrigerator should be emptied, cleaned with a solution of bicarbonate of soda or anti-bacterial solution and the door left ajar.

The hob/oven should be thoroughly degreased and cleaned. If using one of the stronger oven-cleaners on the market be sure to allow plenty of ventilation whilst working. If necessary burner jets can be

brushed over with a stiff brush, and blockages cleared with a high-pressure air line. Never try to clear blocked jets with a piece of wire which can damage or enlarge jet holes.

Water heaters must be drained and care must be taken to remove any lurking pools of water or frost damage may result. If possible blow air through the heater to push any water droplets through. Leave drain taps and inlets open.

The water pipes can be flushed through with a proprietary sterilising agent and the waste pipes with a stronger disinfectant. Make sure the water pump is drained and remove the water filter. Fresh and waste water containers should be cleaned, drained and stored with caps loose or off. Leave all water inlets and outlets open, but they may be covered with a fine mesh material (eg stocking) to prevent entry of insects etc.

The toilet should be cleaned according to the manufacturer's instructions, using a suitable disinfectant for the holding tank. Rinse all sections thoroughly and store unsealed. Any rubber seals or diaphragms can be lubricated with olive oil to prolong life.

## 5. Battery

Unless powering an alarm system, the 12v battery should be removed, wiped over, the terminals cleaned and smeared with petroleum jelly. The electrolyte level should be checked and topped up with distilled water if necessary. Trickle charge from the mains until you obtain a reading of 12.6v on a voltmeter or 1.27 on a hydrometer. Store the battery in a cool, dry place and check the state every 6-8 weeks. Top up the charge as required.

Electric clocks, smoke detectors etc, if fitted, should have their internal battery removed. Battery powered burglar alarms may benefit from a new set of batteries for the winter.

## 6. Awning

The awning should be spread out on dry grass or concrete and brushed with a broom to remove any mud. If the canvas is stained try removing the marks with a stiff brush and plain water. If this fails pure soap flakes can be tried, which will mean re-proofing is necessary afterwards, but never use detergents. If stains are stubborn there are proprietary cleaners such as Fabsil Universal Cleaner, available from caravan accessory shops, or contact Grangers International Tel: 01773 521521. Any mildew spots can be treated with a weak solution of hydrogen peroxide – scrub into the affected area and allow to dry before re-proofing (spot test a

hidden area in case colour is affected). Such severe treatment will weaken the awning material so live with stains if you can! Clear windows can be cleaned with methylated spirits if water doesn't work, but nothing stronger. Examine seams and repair any broken stitching and replace perished rubber tensioners. Give the awning a good shake and pack it when completely dry, trying not to put too many creases in the window. Store in a dry, vermin free area.

Awning poles need little attention other than a wipe down with a damp cloth. Don't oil or grease them as this may get onto the canvas. Pegs can be cleaned and straightened and any badly damaged ones can be replaced ready for the next season.

## 7. Exterior

Your caravan is constructed through the use of several types of materials, paints and coatings in the course of manufacture. Side walls have strengthening inserts in areas which are painted or coated, such materials vary in their make up and over time react differently in opposing areas to atmospheric, chemical and UV influences.

In some instances this can result in a yellowing or matting of components and finishes to varying degrees. This UV or chemical yellowing in no way compromises the usability or performance of the product

and if desired, in most cases, can be restored by polishing with a compound such as T-Cut (always follow the manufacturers recommended guidelines). The caravan will also benefit with regular thorough cleans with a car wash wax type of shampoo.

Look over the rubber window seals and replace any that look perished. Coat serviceable rubbers with olive oil. If you have a damp meter check around the inside for any trouble spots and re-seal suspect joints. Any major damp penetration problems should be resolved before storage. Minor leaks might be cured using Captain Tolley's Creeping Crack Cure. Major leaks require complete renewal of the sealant; both products should be available from caravan accessory shops.

## 8. Chassis

The chassis should be brushed off, or if exposed to corrosive elements, eg road salt, thoroughly washed down. Any surface rust can be removed with a wire brush or sandpaper and the chassis and axle tube can be painted with a rust inhibitor, suitable paint (eg Hammerite) or Finnigan's Waxoyl. The coupling and all winding mechanisms should be degreased, examined for wear then re-greased.



## GENERAL DATA

---

### 9. LPG cylinders

LPG cylinders should be removed and stored in a cool, ventilated location. Some storage compounds will insist they are removed to comply with fire safety regulations. The regulator and/or pipe end can be covered with a stocking or similar to prevent the entry of debris or insects that can block the gas supply.

### 10. Electrics

13 pin, 12N and 12S plugs should be inspected and cleaned and the pins coated with vaseline. WD40 should not be used as it may 'melt' some plastics on contact. The plugs should be protected from the weather but not fully sealed in polythene which will encourage condensation. Road lights should be checked and any water ingress cured, full inspection and cleaning can be done now or left to the springtime service.

### 11. Axle stands

Ideally the caravan should be jacked up and supported on axle stands with the wheels clear of the ground. Wheels can be removed if desired and stored in a cool, dark place at normal inflation pressure. Inspect tyres carefully and make a note to renew any suspect ones before using the caravan again. The corner steadies should be lowered and rested on blocks if they do not

reach the ground. The handbrake should be left off and the wheels rotated from time to time to keep the bearings lubricated.

### 12. Security

Finally remove any valuables and documents from the caravan to make it secure; thieves do not hibernate for the winter!

Please note that neither Lunar Caravans Ltd nor The Caravan Club endorse any of the listed products and you should satisfy yourself as to their suitability. As always, check that the installation of an after-market accessory does not invalidate your warranty.

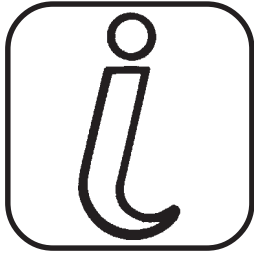

# Contents

Warranty .....	120
Annual Inspection .....	124
Annual Service Record .....	126
Change of Ownership .....	129



## WARRANTY

### Lunar Caravans Owners Warranty 2019

#### Introduction

Congratulations on becoming a Lunar owner. We trust your Lunar Caravan to provide a long and trouble free service. However, in the unlikely event that you do have a problem or a fault does arise, it is important that you understand the contents of the Lunar owner's warranty and follow the correct procedures to ensure that you receive the full benefit of this protection.

Your warranty commences on the day your new caravan is purchased and ends on the anniversary of that date in the 6th year. It is important that as an owner you complete the "Validate your Warranty" section located on our website. Please visit <http://www.lunarcaravans.com/validate-your-warranty>. If you experience any problems in validating your warranty or do not have access to a computer, please contact your dealership who can do this on your behalf.

Your warranty comprises of three key elements:

1. 1 year warranty
2. 3 year warranty
3. 6 year warranty

**Year 1 Warranty** - covers all original components, including permanently fitted equipment forming part of the original product specification. It covers all components arising from manufacturing defects, but not those which are the result of normal wear and tear.

**Years 2 and 3 Warranty** - Covers all original components listed below, including permanently fitted equipment forming part of the original product specification but not those which are the result of normal wear and tear or the cleaning and adjustment of any assemblies. Lunar will require proof of servicing which will be the fully detailed original service invoice. Failure to keep/ provide such records and information will invalidate the Lunar warranty.

**Heating system (Alde)** - control unit, switches, flame device failure, ignite (excluding ducting and fittings)

**Heating system (Truma)** - control unit, switches, flame device failure, ignite (excluding ducting and fittings)

**Cooker** - the cooker unit inc. burners, grill and flame failure device and ignitors

**Fridge** - door seal, gas ignite, flame failure device, 12 & 230V thermostat, 230V temperature control switch

**Water system:** water heater, water gauges, fresh water tank

**Cassette toilet** - complete toilet excluding seals, valves and glands

**Electrics** - battery charger, distribution unit, mains hook up and input connector

**Chassis** - all chassis members

**Towing mechanism** - all mechanical components fitted

**NB.** Appliances carry their own manufacturer warranty, the maximum of which is three years.

**Years 4, 5 and 6 Warranty** - Lunar Caravans are covered against water ingress and delamination of the floor for six (6) years. This applies to water ingress through any permanently sealed seam joints, not including the structural integrity of panels ie. crack or damage.

*Disclaimer: The contents of this Service book are as accurate as possible at the time of going to print. Lunar Caravans reserve the right to alter materials and specifications without prior notice.*





Below is a list of manufacturers who should be contacted direct by your dealer should any warranty issues arise.

## OEMS CARRYING DIRECT WARRANTY WORK & ADMINISTRATION

Company	Component	Contact	Warranty Term	Telephone No	Fax No	Email
Alde International	Heating System	Customer Care	36 months	01933 677765 Press 1	01933 674975	info@alde.co.uk
AL-KO	Chassis, Axle & Under Gear	Service Department	36 months	01926 818200		
Base Automotive	Radio/DVD	Customer Services	12 months	01772 886000		
Sargent Electrical Services Ltd	Power supply units, chargers control panels	Customer Support	36 months	01482 678981	01482 678987	support@sargentltd.co.uk
	Tracker	Customer Support	12 months	01482 678981	01482 678987	support@sargentltd.co.uk
Dometic	Fridges + Blinds	Service Department	36 months	0344 6260132		technical@dometic.co.uk
Grade UK	Status Antennas	Warranty Department	24 months	0115 9867151		
Fire Angel	Smoke Alarms & Carbon Dioxide Alarms	Technical Support Line	12 months	0800 1412561		technicalsupport@fireangel.co.uk
Thetford	Toilets Oven	Customer Services	24 months	01283 86020		
Truma	Water System Heating Systems	Customer Services	36 months	01709 766770		
Apelson	Microwave	Wendy Frost	12 months	01977 628109		service@apelson.co.uk



## WARRANTY

### Reporting a fault

In the event that your experience a fault with your Lunar Caravan, contact should always be with the dealer from which you purchased your caravan. Your dealer is with whom your Contract of Sale is with and ultimately who will be responsible for carrying out pre-delivery inspections and arranging warranty work which may be required together with annual servicing. Any Lunar approved dealer or AWS approved workshop can undertake any warranted work at their convenience or discretion but are not obliged to do so if the caravan was not purchased from them.

All Lunar Caravans are classed as towing vehicles, therefore all work under warranty requires the caravan to be delivered and collected from the selling dealer. This includes delivery/collection for initial assessment for the dealer to submit a warranty claim.

### Servicing

It is important that to maintain the validity of the Lunar warranty, your caravan has an annual service and damp check by an Approved workshop using genuine parts, recommended sealants and following Lunar procedures; failure to do so will invalidate your warranty. Your service handbook must be stamped accordingly and the original VAT invoice and damp report must be retained as proof that the annual service have been carried out in the accordance with the warranty terms and conditions

### Service intervals

In years 1, 3 and 6 the service must be completed no more than 60 days before or on the anniversary of the date of purchase and must not exceed that date.

In years 2, 4 and 5 the services must be completed no more than 60 days either side of the anniversary of the date of purchase. No service interval should exceed 14 months.

Should any faults be identified during service, temporary steps should be taken as preventative measures and in any event the customer must take all steps as reasonable to have the repairs completed temporarily or otherwise within 6 weeks of the service date. Failure to service the caravan within the specified time limits will invalidate the warranty.

### Mains Electrics

It is strongly recommended that your caravan mains electrics system is inspected by a NICEIC approved engineer every 3 years.

### Change of Ownership - Transfer of Warranty

The Lunar warranty may be transferred to a new owner if the caravan is sold on. This is providing the caravan has been regularly serviced by a Lunar or NCC Approved Workshop (AWS - Approved Workshop Scheme). The transfer can only be made within 28 days of the date subsequent ownership was taken and full documentary evidence that the vehicle has been serviced annually along with evidence of the sales receipt must be provided. An administration fee of £50 is required. A copy of the change of ownership/transfer of warranty form can be found at the back of the handbook.

Terms and Conditions, Exclusions and Liability

1. The warranty validation must be completed within 28 days of purchase
2. An annual service has been undertaken on the caravan by a Lunar or NCC approved workshop (AWS - Approved Workshop Scheme).
3. The first, third and sixth service must be carried out before the anniversary of the date of purchase.
4. A record of each service should be recorded and stamped in the "service record" section at the handbook.



5. No warranty work should be commenced under the terms of the warranty unless prior authorisation is obtained from Lunar caravans Ltd.
6. The warranty holder must notify the dealer of the alleged defect within 14 days of discovering it, with sufficient particulars including VIN number to enable the defect to be clearly identified.
7. Should any faults be identified during service, temporary steps should be taken as preventative measures and in any event the customer must take all steps as reasonable to have the repairs completed temporarily or otherwise within 6 weeks of the service date.
8. The manufacturer Vehicle Identification Number (VIN) of the caravan must not be removed or defaced.
9. The caravan must not have been used other than for recreational purposes i.e. living in or business purposes with usage not exceeding 3 months at any one time.
10. No liability will be accepted for alternative accommodation.
11. Repair or replacement of parts, components, seams or panels which are not part of the original construction of the caravan, or have been tampered with or undergone unauthorised modifications, or which have been repaired otherwise than by an Lunar or NCC Approved Workshop.
12. If the caravan has been subjected to any collision, impact or accident, repairs must be undertaken by a Lunar or NCC Approved Workshop.
13. The caravan shall only be towed by a private car or private 4x4 vehicle. It is not to be put out to hire or any other commercial use, nor used in any race, rally or other competitions.
14. Lunar Caravans reserves the right to inspect the caravan prior to commencement of repairs.
15. In the event of a dispute Lunar Caravans Ltd reserve the right to subject the caravan to an expert assessment and nominate a repairer.
16. No liability will be accepted for damage caused by neglect, intrusion, lack of servicing, over-heating, freezing or abuse, (e.g. Continued use after failure has become evident thus exacerbating the problem)
17. No liability will be accepted for the cost of transporting, towing, or moving from or to a place of repair or consequential cost relating to transportation. Be that a Lunar Caravans Ltd nominated repair or otherwise.
18. No liability will be accepted for consequential cost or lost, damage by forces of nature, damage by vermin, damage by mould or damage cause by modification.
19. Retailers/dealers have no authority to bind to make any undertaking on behalf of Lunar Caravans Ltd by any express or implied undertaking or representation.



# ANNUAL INSPECTION

## ANNUAL SERVICE CHECKLIST

In order to comply with the warranty, you must have your caravan serviced and inspected by an authorised appointed dealer covering the items listed every 12 months.

It is important that the service handbook is stamped on the appropriate page by the appointment dealer. Failure to do this will invalidate the warranty.

In the event of a claim, Lunar will require acceptable proof of servicing which will be the fully detailed, original VAT service invoice.

1. Water Ingress Test \_\_\_\_\_ 
  - 1.1 Roof / Walls /Rooflights \_\_\_\_\_
  - 1.2 Floor \_\_\_\_\_
  - 1.3 Windows \_\_\_\_\_
  - 1.4 Doors (entrance/service lockers and frames) \_\_\_\_\_
  - 1.5 Sealant check, reseal if signs of wear or breakdown \_\_\_\_\_
2. Lamination Test \_\_\_\_\_ 
  - 2.1 Sides \_\_\_\_\_
  - 2.2 Floor \_\_\_\_\_
3. Jockey wheel \_\_\_\_\_
4. Chassis and chassis to body security \_\_\_\_\_
6. Corner steadies \_\_\_\_\_
7. Tyres and tyre pressures \_\_\_\_\_
8. Wheel torque nut \_\_\_\_\_
9. Brake rods and linkages \_\_\_\_\_
10. Handbrake operation and performance \_\_\_\_\_
11. Suspension and shock absorbers (if fitted) \_\_\_\_\_
12. 12N and 12S 7 pin plug and cables \_\_\_\_\_



13. Road lights, wiring and reflectors \_\_\_\_\_
14. Internal lights and 12V DC system \_\_\_\_\_
15. Water heater - gas and 230V AC \_\_\_\_\_
16. Hob, grill and oven \_\_\_\_\_
17. Refrigerator 230V, 12V DC and gas \_\_\_\_\_
18. Gas system \_\_\_\_\_
19. Water pump, taps and water system \_\_\_\_\_
20. Mains 230V AC system \_\_\_\_\_
21. Windows and fittings \_\_\_\_\_
22. Smoke alarm \_\_\_\_\_
23. Carbon monoxide alarm \_\_\_\_\_
24. Rooflights \_\_\_\_\_
25. Furniture hinges/stays \_\_\_\_\_
26. Exterior locks and hinges \_\_\_\_\_
27. Grab handle security \_\_\_\_\_
28. All internal vents \_\_\_\_\_
29. Oil seals \_\_\_\_\_
30. Blinds/flyscreens \_\_\_\_\_
31. Blown air heating and gas fire heater \_\_\_\_\_



# ANNUAL SERVICE RECORD

CARAVAN MODEL \_\_\_\_\_ YEAR \_\_\_\_\_

CHASSIS (VIN) NUMBER \_\_\_\_\_

<p><b>1st INSPECTION</b></p> <p>DATE:</p> <p>DEALER'S STAMP</p> <p>We certify that an annual inspection has been carried out in accordance with the Service Checklist.</p>	<p><b>2nd INSPECTION</b></p> <p>DATE:</p> <p>DEALER'S STAMP</p> <p>We certify that an annual inspection has been carried out in accordance with the Service Checklist.</p>	<p><b>3rd INSPECTION</b></p> <p>DATE:</p> <p>DEALER'S STAMP</p> <p>We certify that an annual inspection has been carried out in accordance with the Service Checklist.</p>
<p><b>4th INSPECTION</b></p> <p>DATE:</p> <p>DEALER'S STAMP</p> <p>We certify that an annual inspection has been carried out in accordance with the Service Checklist.</p>	<p><b>5th INSPECTION</b></p> <p>DATE:</p> <p>DEALER'S STAMP</p> <p>We certify that an annual inspection has been carried out in accordance with the Service Checklist.</p>	<p><b>6th INSPECTION</b></p> <p>DATE:</p> <p>DEALER'S STAMP</p>



If you sell your caravan and the new owner wishes to benefit from any unexpired warranty, please notify us of any change of ownership by completing the change of ownership form on the next page.

An administration charge of £50 is also applied and cheques should be made payable to Lunar Caravans Limited and full documentary evidence that the caravan has been annually serviced be enclosed. The change of ownership form must be completed within a month of change of legal ownership and all documentation should be sent to:

Lunar Caravans Limited  
After Sales Department  
Sherdley Road  
Lostock Hall  
Preston  
PR5 5JF





# CHANGE OF OWNERSHIP



## NOTIFICATION OF CHANGE OF OWNERSHIP

PURCHASE DATE		PURCHASED FROM (DEALER NAME IF APPLICABLE)	
---------------	--	---	--

### CARAVAN DETAILS

Model	
Vehicle Identification Number	

### CURRENT OWNER

Name	
Address	
Post Code	
Telephone Number	
Date of Ownership	

### NEW OWNER

Name	
Address	
Post Code	
Telephone Number	
Date of Purchase	

### PLEASE FORWARD THIS FORM, WITH A COPY OF YOUR SALES RECEIPT TO:

Lunar Caravans Limited, After Sales Department, Sherdley Road, Lostock Hall, Preston, PR5 5JF.

From time to time our Marketing Department may use the information recorded on our database to inform customers of new products and updates. If you wish to opt out from this, please tick

I have read and understand the terms and conditions of the Lunar warranty, including the servicing requirements as applicable to this vehicle.





## NOTIFICATION OF CHANGE OF OWNERSHIP

PURCHASE DATE		PURCHASED FROM (DEALER NAME IF APPLICABLE)	
---------------	--	---	--

### CARAVAN DETAILS

Model	
Vehicle Identification Number	

### CURRENT OWNER

Name	
Address	
Post Code	
Telephone Number	
Date of Ownership	

### NEW OWNER

Name	
Address	
Post Code	
Telephone Number	
Date of Purchase	

**PLEASE FORWARD THIS FORM, WITH A COPY OF YOUR SALES RECEIPT TO:**

Lunar Caravans Limited, After Sales Department, Sherdley Road, Lostock Hall, Preston, PR5 5JF.

From time to time our Marketing Department may use the information recorded on our database to inform customers of new products and updates. If you wish to opt out from this, please tick

I have read and understand the terms and conditions of the Lunar warranty, including the servicing requirements as applicable to this vehicle.



# CHANGE OF OWNERSHIP



## NOTIFICATION OF CHANGE OF OWNERSHIP

PURCHASE DATE		PURCHASED FROM (DEALER NAME IF APPLICABLE)	
---------------	--	---	--

### CARAVAN DETAILS

Model	
Vehicle Identification Number	

### CURRENT OWNER

Name	
Address	
Post Code	
Telephone Number	
Date of Ownership	

### NEW OWNER

Name	
Address	
Post Code	
Telephone Number	
Date of Purchase	

### PLEASE FORWARD THIS FORM, WITH A COPY OF YOUR SALES RECEIPT TO:

Lunar Caravans Limited, After Sales Department, Sherdley Road, Lostock Hall, Preston, PR5 5JF.

From time to time our Marketing Department may use the information recorded on our database to inform customers of new products and updates. If you wish to opt out from this, please tick

I have read and understand the terms and conditions of the Lunar warranty, including the servicing requirements as applicable to this vehicle.





## NOTIFICATION OF CHANGE OF OWNERSHIP

PURCHASE DATE		PURCHASED FROM (DEALER NAME IF APPLICABLE)	
---------------	--	---	--

### CARAVAN DETAILS

Model	
Vehicle Identification Number	

### CURRENT OWNER

Name	
Address	
Post Code	
Telephone Number	
Date of Ownership	

### NEW OWNER

Name	
Address	
Post Code	
Telephone Number	
Date of Purchase	

**PLEASE FORWARD THIS FORM, WITH A COPY OF YOUR SALES RECEIPT TO:**

Lunar Caravans Limited, After Sales Department, Sherdley Road, Lostock Hall, Preston, PR5 5JF.

From time to time our Marketing Department may use the information recorded on our database to inform customers of new products and updates. If you wish to opt out from this, please tick

I have read and understand the terms and conditions of the Lunar warranty, including the servicing requirements as applicable to this vehicle.





<b>A</b>		<b>G</b>		<b>S</b>	
Arrival on Site .....	28	Gas .....	42	Security .....	34
Levelling the caravan .....	28	Gas Bottles .....	42	Datachip Security Card .....	34
Siting/Unhitching .....	28	Gas Safety Advice .....	44	Smoke Alarm .....	32
Awning Fixing Points .....	88	Precautions .....	44	Speed Limits .....	26
		Types of Gas .....	43	Stabiliser, AKS2004 .....	12
<b>B</b>		General Data .....	113	Stability .....	9
Battery .....	62	Lunar Owner's Club .....	114	Stabilisers .....	9
Blinds .....	93	Security .....	113	Sterilising .....	38
Bulb Replacement .....	113				
<b>C</b>		<b>H</b>		<b>T</b>	
Caravan Handling .....	26	Heater .....	67	Toilet	
Caravan Towing Code .....	4			Cassette Toilet C-260 CWE .....	84
Carbon Monoxide Alarm .....	33	<b>J</b>		Truma Combi Boiler .....	66
Chassis & Undergear		Jacking Points .....	27	Tyres .....	22, 104
General Notes on Maintenance .....	103			General Recommendations .....	104
<b>D</b>		<b>L</b>		Tyres & Pressures .....	104
Distribution of Weight .....	8	Lighting .....	92		
<b>E</b>		<b>M</b>		<b>W</b>	
Electrics .....	46	Mirrors .....	23	Warranty	
13 pin wiring diagram .....	24	Motorway Driving .....	26	Owner's Warranty .....	114
230V Mains Electric Equipment				Water System	
Usage .....	46	<b>N</b>		Helpful Hints .....	41
Instructions for Electricity Supply .....	46	Noseweight .....	6	Pressure Switch .....	41
		Number Plate .....	23	Setting Up the Water System .....	40
<b>F</b>		<b>P</b>		Wheel Changing .....	27
Fire Action .....	32	Power Control System .....	50	Wheel Lock .....	16
Fire Extinguisher .....	33	Pre-load Checklist .....	8	Wheels	
Fire Precautions .....	32	Pre-tow Checklist .....	10	Torque .....	22
Flyscreens .....	93			Winterization Guide .....	116
Fuses .....	58	<b>R</b>			
		Refrigerators .....	71		
		Dometic Model RMS 8500 .....	71		
		Reversing .....	26		
		Road lighting .....	24		



## NOTES

---

Publication Designed and Produced by Preset Graphics Ltd  
Tel: 01332 549278. Fax: 01332 549279. E-mail: [Presetgraphics@btconnect.com](mailto:Presetgraphics@btconnect.com)  
Ref: 21664 © All Rights Reserved