

CONTENTS

TOWING CODE



PREPARING FOR THE ROAD



ON THE ROAD



FIRE & SAFETY



SERVICES



ELECTRICS



FITTED EQUIPMENT



AL-KO CHASSIS & TYRES



GENERAL DATA



INTRODUCTION

INTRODUCTION

Lunar Caravans welcomes you as you join the ranks of owners of Alaria Caravans. We hope you will enjoy your caravan and this handbook tells you how to look after it so that it may give you years of pleasure and enjoyment.

Remember that it is a vehicle and thus calls for a small amount of regular maintenance.

You are requested to contact your dealer on all enquiries in order to ensure satisfaction. You will only experience delays if you bypass the normal channels.

Your Alaria Caravan has been European Commission Whole Vehicle Type approved via LuxControl and has also been inspected by the National Caravan Council (NCC) to ensure your new caravan is compliant and safe to use.

Your caravan has been built and approved to EN1645 which applies to a large number of features such as:

- sizes of beds
- escape factor i.e. windows and exterior door
- materials
- design and construction

- insulation is grade 3 classified which is able to achieve an average temperature difference of 35 degrees centigrade between interior and exterior when the exterior is -15 degrees centigrade
- electrical equipment, both 12 volt and 230 volt
- chassis
- undergear
- drawbar
- jockey wheel
- wheels and tyres
- installation of gas
- ventilation
- awnings and channel
- fire notices
- handbook

Touring caravans are designated by their model year which runs from 1 September to 31 August. A new year model can only be registered by CRIS from 1st September onwards.

This caravan has been security marked and recorded under the Caravan Registration and Identifications Scheme that is organised by the Caravan Industry.

Please see Cris, General Data section on how your caravan can be uniquely identified.

To protect yourself and your touring caravan, never leave the Registration Document in the caravan. For security reasons keep it in a safe place.

Disclaimer: The contents of this Handbook book are as accurate as possible at the time of going to print. Lunar Caravans reserve the right to alter materials and specifications without prior notice.



TOWING CODE

Scope of Code	4
Caravan Terms	4
Weights	4
Towing Vehicle Terms	4
Measurement of Noseweight	6



TOWING CODE

THE CARAVAN TOWING CODE

Industry Payload Standard for UK touring Caravans

This standard has been prepared by the National Caravan Council and formulated with input from Industry Experts. The standard applies to UK specification Touring Caravans and will apply for the NCC certification from 2011 onwards model year Touring Caravans.

From the 2012 model year onwards, the method of calculating the Mass in Running Order (MRO) and user payload figures are in line with European Vehicle Directives and conform to requirements for European Whole Vehicle Type Approval EWWTA, 2007/46/EC (The Framework Directive) and the directives referenced therein.

Other Notable Weights/Capacities

- 1) 9kg of water in the water heater.
- 2) 2kg of water in the toilet holding tank (this is the maximum recommended by Thetford).
- 3) The weight of the spare wheel is 17.5kg.

DEFINITIONS

Maximum Technically Permissible Laden Mass (MTPLM)

The fully laden mass of the caravan in the manufacturer's standard specification which is stated in the manufacturer publications by the manufacturer for tow car matching. This mass takes into account the specific operating conditions including factors such as the strength of the materials, load capacity of the tyres etc, and can be found on a plate affixed to the caravan, usually near the entrance door.

Please note: The MTPLM is the maximum weight that the caravan can be loaded to, this mass must NOT be exceeded. However most models can have the MTPLM upgraded in capacity; this must be approved by Lunar Caravans Ltd via the dealership. Please contact your dealership for further details.

Mass In Running Order (MIRO) or (MRO)

This is the weight of the caravan as it leaves our factory (inclusive of the electrical hook-up cable at 6kg and the winding handle at 1kg) plus the following:

8kg gas bottle allowance.

Note: The MRO is calculated with the water tanks empty, any water in the tanks during travel must be accounted for in the user payload. It is also advisable to empty such tanks prior to transit.

User Payload (UP)

The difference between the MIRO and MTPLM (excluding potential MTPLM upgrade). The user payload allows for items common to all occupants, such as food, cutlery, pots, pans, clothing, footwear, bedding, sports equipment etc. The user payload also includes an allowance for the auxiliary battery.

The UP is calculated by the following formula:

$$10L + 10N + 50.$$

L is the body length of the caravan in meters.

N is the number of berths.

50 is for normal equipment carried in the caravan, a sample list is given below.

TV	3kg
Kettle	0.5kg
Bed linen	6kg
Crockery	5kg
Saucepans	3kg
Wastemaster	6kg
Aquaroll (empty)	5kg
Waste bin	1kg
Cutlery	2kg
Toilet fluid etc	2.5kg
Battery	16kg



Optional Equipment Payload (OEP)

Items made available by the manufacturer over and above the standard specification for the caravan in addition to the user payload.

Personal Effects Payload (PEP)

A mass specified for the items which a user can choose to carry in a caravan and which are not included as an essential habitation equipment or optional equipment.

Optional Item	Additional Weight
R/C Alarm/Awning Light	1 kg
AL-KO Secure wheel locks (per lock)	2 kg
AI-KO ATC Trailer Control	2 kg
Air Conditioning	30 kg
Whale 40L Underslung water tank	47 kg

Please note: Any options fitted by retailer will reduce the overall payload available to the customer.

REGULATORY AND SAFETY ADVICE

WARNING: UNDER NO CIRCUMSTANCES SHOULD THE MAXIMUM TECHNICALLY PERMISSIBLE LADEN MASS (MTPLM) BE EXCEEDED. PLEASE TAKE CARE TO ENSURE THAT YOU HAVE ALLOWED FOR MASSES OF ALL ITEMS YOU INTEND TO CARRY IN THE CARAVAN e.g. Optional equipment and personal effects such as clothing, food, pets, bicycles, sailboards, sports equipment etc.

THE MASS OF THE CARAVAN IN RUNNING ORDER (MIRO) CONTAINS PROVISION FOR THE MASSES OF LIQUIDS, GAS ETC. PART OF THIS PROVISION CAN ALSO BE UTILIZED AS ADDITIONAL PAYLOAD IF FOR EXAMPLE YOU WISH TO TRAVEL WITH NO GAS CYLINDERS.

THE CARAVAN AND TOWING VEHICLE RATIO

This can be determined by calculation and is equal to:

$$\frac{\text{actual laden weight of caravan}}{\text{kerb weight of towing vehicle}} \times 100\%$$

THE **LAW** REQUIRES THAT CARAVANS & THEIR TOWING VEHICLES & THE LOADS THEY CARRY MUST BE IN SUCH A CONDITION THAT NO DANGER OR NUISANCE IS CAUSED.

(Regulation 100 of the Road and Vehicles [Construction and Use] Regulations 1986).

IMPORTANT NOTICE:

Your caravan has been designed and manufactured for towing behind normal road cars. Additional care should be taken when towing with a 4x4 due to the 'off-road' nature of the suspension. Caravans are not suitable for towing behind commercial vehicles.

POWER TO WEIGHT RATIO:

No hard and fast rules can be stated but, here is a general guide.

- (a) Conventional petrol engines with a capacity up to approximately 1500 cc should be adequate for towing a caravan weighing around 85% of the kerb weight of the towing vehicle.



TOWING CODE

- (b) Above 1500 cc such engines should manage a caravan weighing up to 100% of the kerb weight of the towing vehicle and still give adequate performance.

Note: The towing vehicle manufacturer's limit is, in some cases, less than the kerb weight.

Vehicles with automatic transmission may need an oil cooler to be fitted or the SAE rating of the gearbox oil increased when towing. The advice of the vehicle manufacturer should be sought.

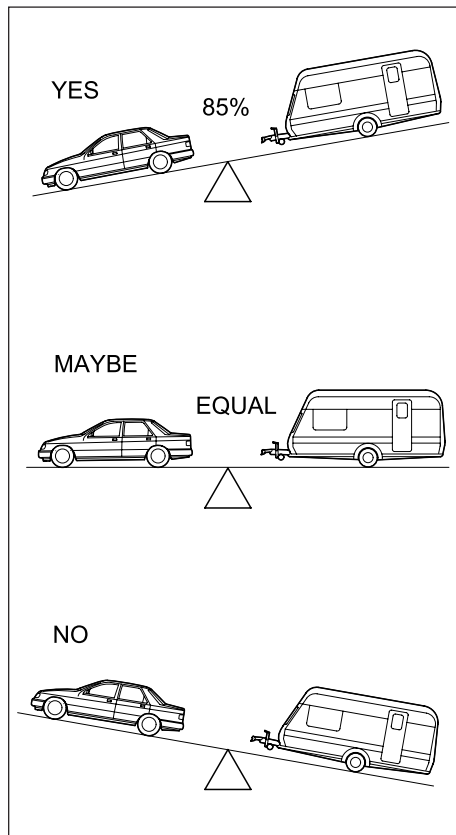

MEASUREMENT OF NOSEWEIGHT

Towing noseweight should be a minimum of 50kg and heavier for twin axle models. This may be measured using a proprietary brand of noseweight indicator. Such equipment is obtainable at your Alaria Caravan Dealer.

Another simple method is to use bathroom scales under the coupling head with a piece of wood fitted between the coupling head and the scales, of such length that the caravan floor is horizontal with the jockey wheel raised.

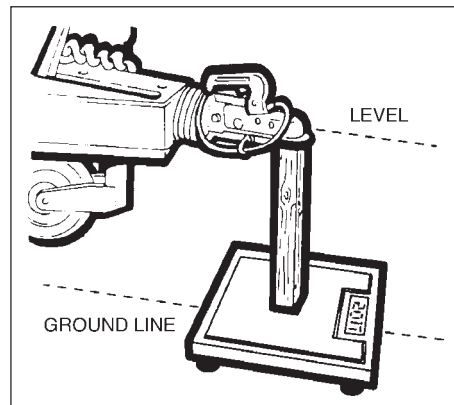



PREPARING FOR THE ROAD

Checklist	8
Loading and Distribution	8
Stability	9
Pre-Tow Checklist	10
Stabiliser	12
Wheel Lock	16
Breakaway Cable	20



PREPARING FOR THE ROAD

PRE-LOAD CHECKLIST

CAUTION: Never enter the caravan without first lowering the four corner steadies with the brace provided.

CHECK THAT:

- loose articles are stowed securely. Do not stow tins, bottles or heavy items in overhead lockers prior to towing.
- all lockers and cupboard doors are closed and secured.
- all bunks are secure.
- all rooflights are closed and secured.
- main table is stored in its transit position.
- fridge is on 12v operation and door lock is set.
- all windows are fully closed and latched. Never tow with windows on nightsetting. Leave all curtains and blinds open to aid rear visibility.
- gas cylinders are correctly positioned, secured and turned off.
- battery is secure.
- wheelnuts for tightness.
- tyre pressures and condition of tyres.

LOADING AND DISTRIBUTION OF WEIGHT IN THE CARAVAN

Do not exceed recommended maximum loading for your caravan.

1. Load evenly right to left.
2. Do not load items at the extreme rear

since this can lead to instability due to the 'pendulum effect'.

3. Load remainder to give a suitable noseweight at the towing coupling.
4. Please ensure that your noseweight falls in accordance with the towing vehicle's towball weight limit and doesn't exceed 100kg.
5. Distribute items evenly over the axle and as low as possible to optimize road holding and achieve the best possible braking effect.
6. Do not stow tins, bottles or heavy items in overhead lockers when towing.
7. Loose articles should be stowed securely to avoid movement and possible damage.
8. Ensure that all lockers and cupboard doors are closed and secured.
9. Secure all bunks (if appropriate).
10. Store the main dining table in its transit position.

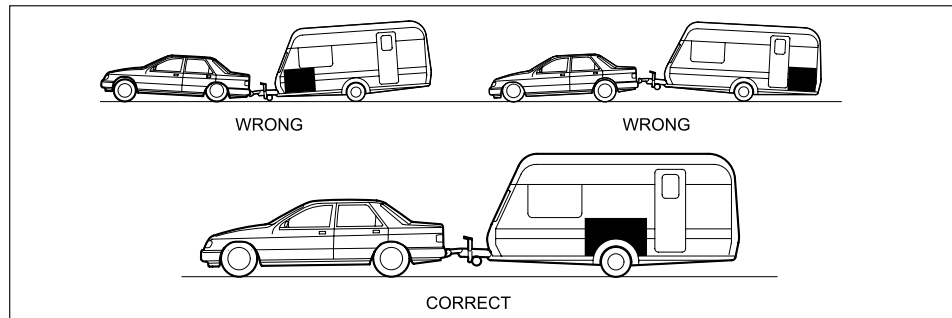
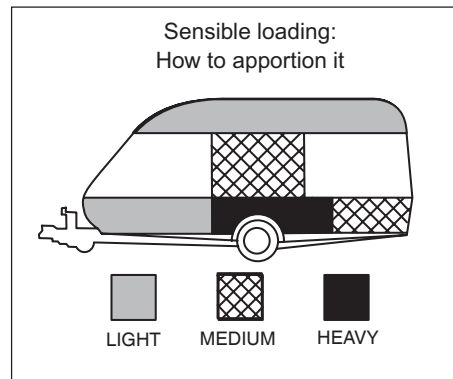

Note: Do not load car boot heavily.



STABILITY

The most common causes of poor stability include:

- (a) Incorrect tyre pressures on car or caravan.
- (b) Worn springs or loose spring fixings on the towing vehicle.
- (c) Towing vehicle shock absorbers too soft.
- (d) Insufficient noseweight.
- (e) Nose of caravan is towing too high.
- (f) Incorrect loading

Stabilisers. There are many proprietary brands of stabiliser available. Your Alaria dealer will be pleased to advise you of the most suitable. They are an aid to stability and should not be considered as a cure for a stability problem.

Note: It is expressly forbidden by the chassis manufacturer for holes to be drilled into the 'A' frame to accommodate a stabiliser bracket. A clamp must be used. Similarly, holes should not be drilled into the coupling head.

Towing vehicle's rear suspension

It is important that the towing vehicle's rear suspension is not deflected excessively by the noseweight on the tow ball. If it is excessive the steering and stability will be affected.

The greater the towing vehicle's tail overhang (the distance between the rear axle and the tow ball) the greater the effect the noseweight will have on the towing vehicle's rear suspension.

After trying out the caravan it may be found that stiffening of the rear suspension is necessary — but note that this may give the towing vehicle a firmer ride when not towing.

There are a number of suspension aids available and advice should be sought on which to use and how to fit.

It is important to ensure that the caravan is towed either level or slightly nose down.

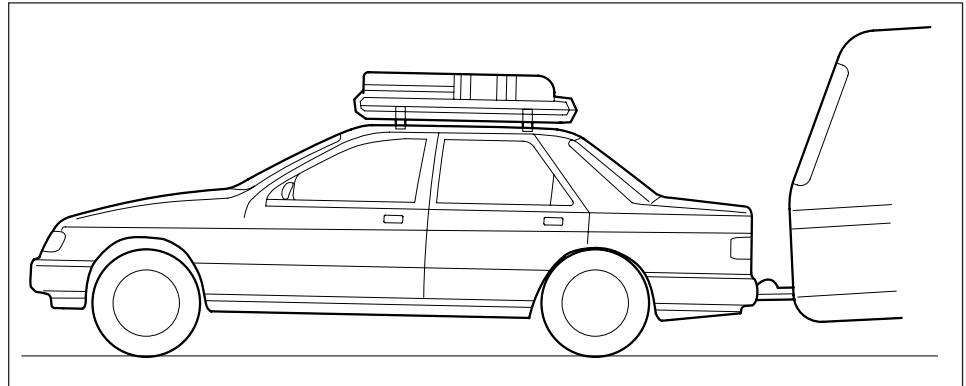

Illustration of excessive deflection of vehicle's rear suspension



PREPARING FOR THE ROAD

PRE-TOW CHECKLIST

1. Check that the hitch is securely coupled onto the towball and connect the breakaway cable. Your hitch height should be around 440mm (17") to the centre of the towball when the towing vehicle and caravan are coupled and laden.
2. The Jockey wheel should be raised and tightly clamped or removed completely if desired.
3. Corner steadies must be wound up fully.
4. Plug in the electrical connection to the car, keeping the cable clear of the road and check the operation of lights.
5. Release the handbrake. "Failure to ensure that the handbrake is completely off, can result in overheating of the brakes and failure of the bearings".
6. Check tyre pressure with cold tyres (see specification). Wheel bolt torque settings (see chart on page 11).
7. Adjust the tyre pressures of your tow car to the manufacturers recommendations for full loads.
8. Engage the stabiliser, if fitted.
9. Fit towing mirrors to your car.

Where access to an internet connection is available please refer to the manufacturer's full operating instructions: www.al-ko.co.uk/pages/original-2.html

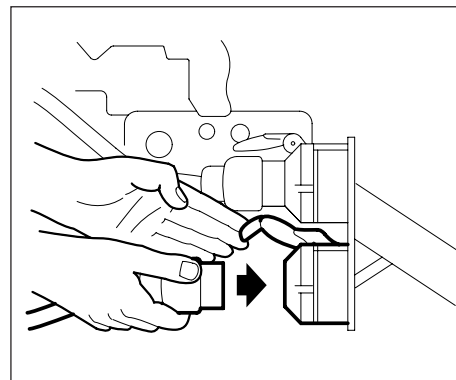
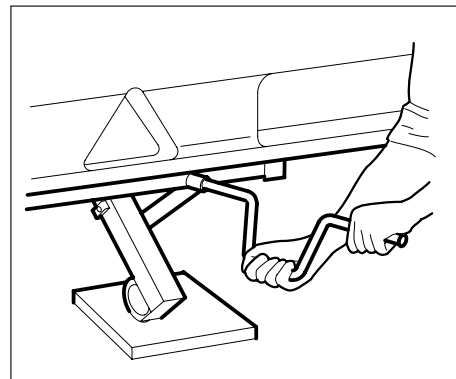
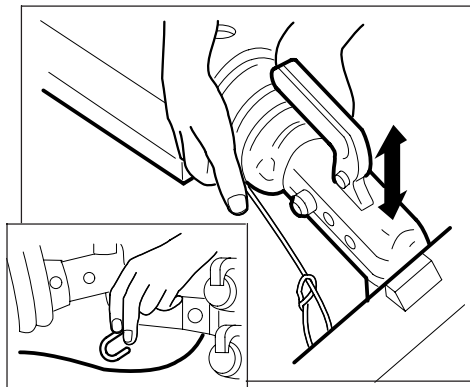



Wheel/Tyre combinations



Assembly 1 - Alaria	
Torque Setting / Bolt Spec	95Nm / M12 x 1.5 (26mm thread) Tensile Strength 10.9, 60 degree conical fixing, 19mm hexagon bolt head.
Tyre Pressure	See Model
Tyre Size	175/65 R14 86T Champiro Eco XL TL
Wheel Description	550X14 5/112 ET30 Black Polish



PREPARING FOR THE ROAD

AKS STABILISER (where fitted)

This model of stabiliser has 4 special friction pads, which suppress both snaking and pitching. It is essential that the tow ball is kept completely clean as contaminated pads will reduce its effectiveness.

Operating instructions

- Using the coupling handle, put the AKS on to the towball. Push the black handle down and check the green indicator button is showing (Fig. 1).
- Press the black stabilising lever down. The AKS is now ready for the road (Fig. 2).

Safety indicators

If the green indicator is visible then you know you have correctly coupled your AKS to your towing vehicle (Fig. 3).

Wear Indicator

For Coupling mechanism and front/rear friction pads. (Fig. 4)

- Wear of the coupling ball and mechanism can be easily monitored. If the green section is visible (when coupled to your towball) then the front/rear friction pads, coupling ball and mechanism are in order.
- If the red lower section obscures the green section then you need to check these parts immediately.

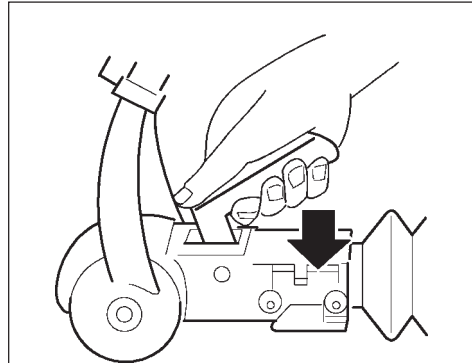

Fig. 1

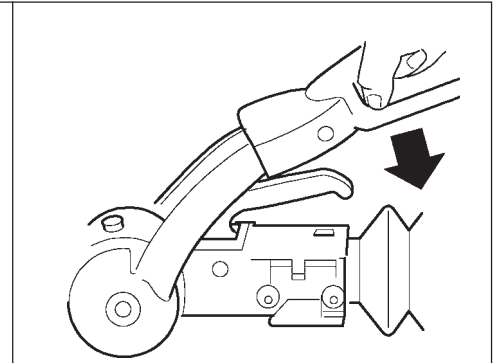

Fig. 2

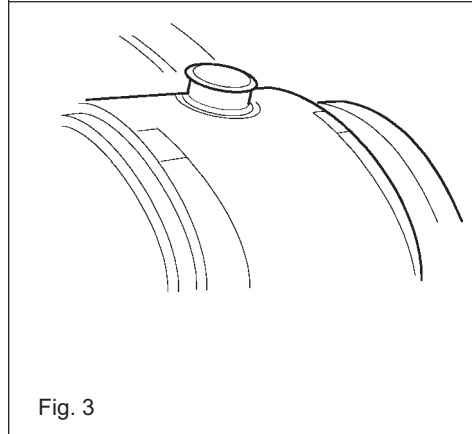

Fig. 3

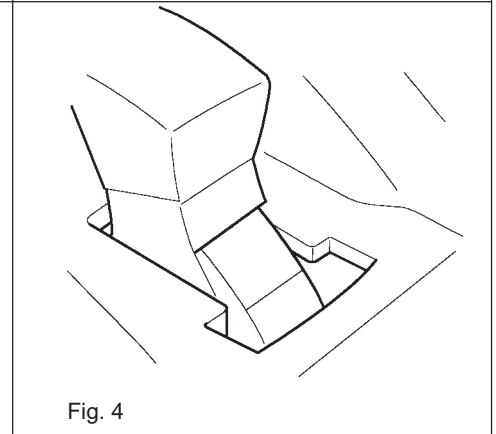

Fig. 4



OPERATING INSTRUCTIONS FOR AKS 3004 STABILISER

Checking the efficiency of the left/right friction pads

1. Check that the stabiliser is correctly coupled by ensuring the coupling handle is fully down and the red indicator button is in the raised position.
2. Push the stabiliser handle down until resistance is felt (ie. the friction pads are in contact with the ball but not yet under pressure (Fig 6/Item 1).
3. Check the position of the arrowhead on the arm of the stabiliser. If it lines up with the two green lines then the friction pads are still as new (Fig 6/A).
4. If the arrowhead lines up with the two red lines then the friction pads are worn and should be replaced immediately (Fig 6/B).

Note: When the stabiliser handle is correctly applied, the arrowhead should line up with the black line marked 2 (Fig 6/C).

Note: The friction pads do not require any form of lubrication and should be cleaned with a fine emery paper prior to every journey. It is not necessary to adjust the friction pads.

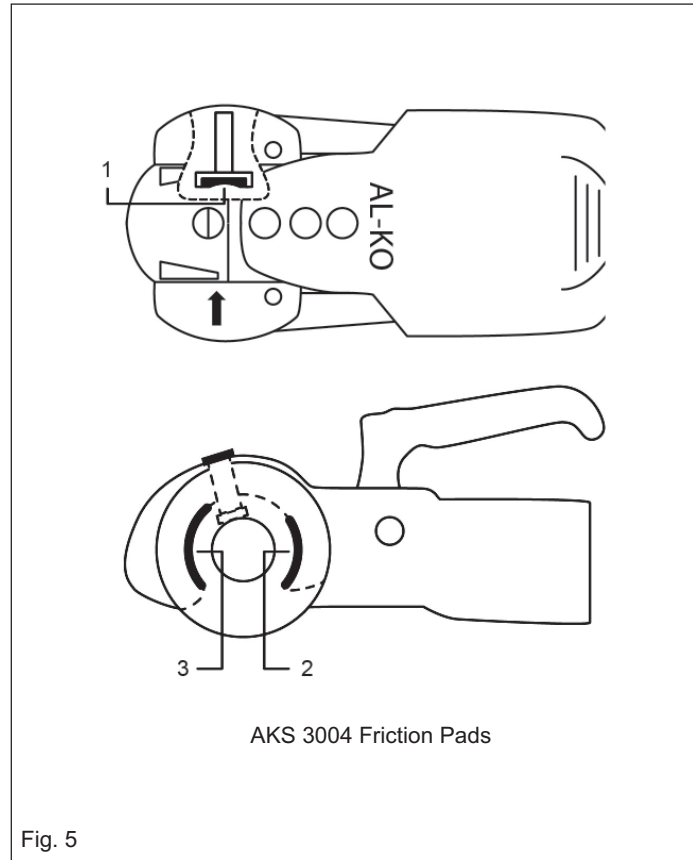
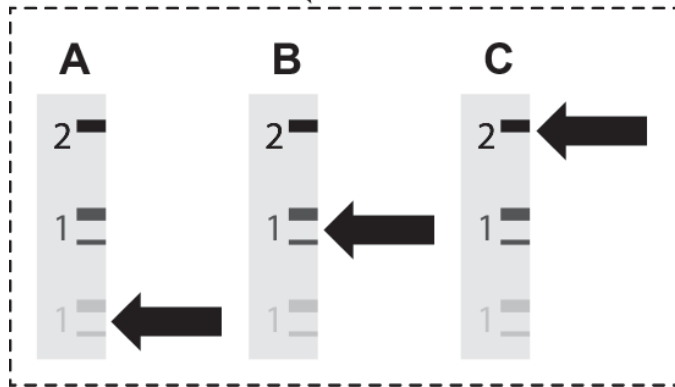
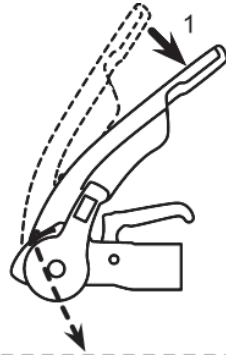

Fig. 5



PREPARING FOR THE ROAD



Checking Left/Right Friction Pads

Fig. 6



Friction Pads Replacement

- Unscrew the 2 screws which are under the soft dock by using the special torx tool (UK version only). (Fig. 7)
- Remove screw from back plate. (Fig. 8)
- Remove friction pads. (Fig. 9)

Loading Capacity

The AKS can be utilised to tow vehicles up to a gross weight of 3000kg and a maximum nose load of 100kg.

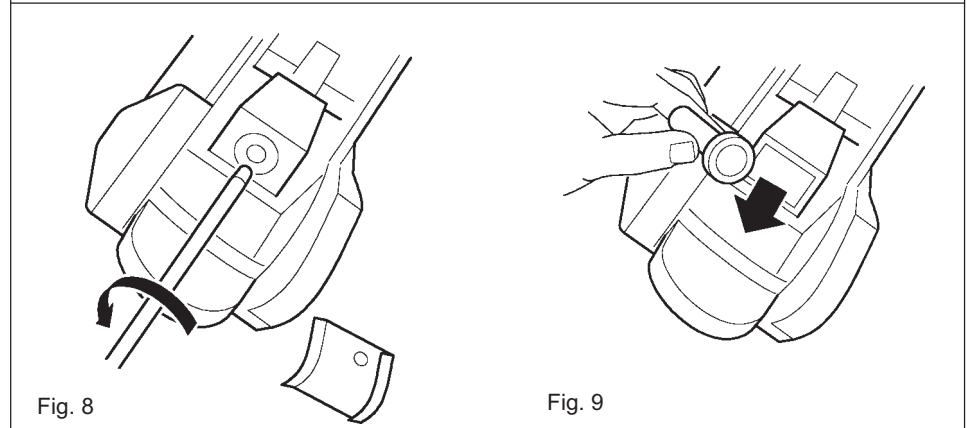
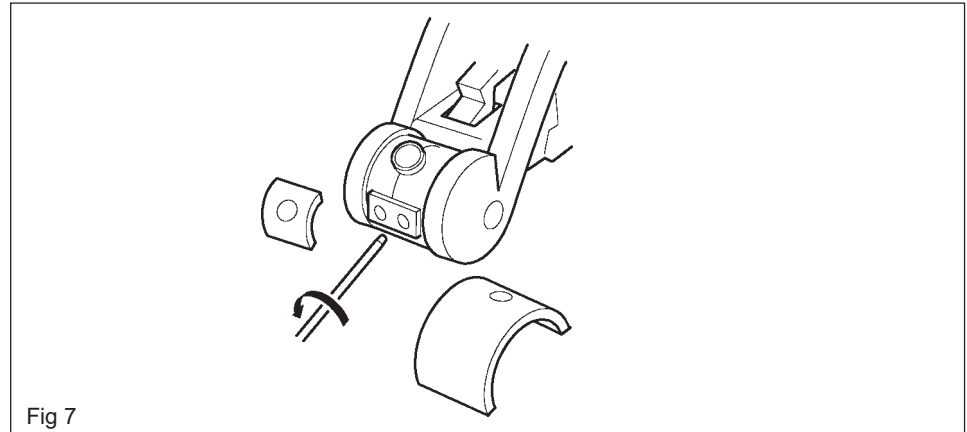



PREPARING FOR THE ROAD

AL-KO SECURE WHEEL LOCK

You must register your key, should you fail to do this you will not be able to order a spare key or obtain lost or stolen keys.

This is how it works:

- On the Al-Ko Secure registration card you will find an exclusive security number.
- Please register your key by telephoning 0870 7576788 or 0044 1926 818500.
- You will be required to provide the chassis number of the caravan.
- You will need to provide us with a password and supply answers to three security questions.
- Make a note of your password and keep it in a safe place.
- Also keep your registration card safe.
- Take your registration card with you when you are travelling with the caravan.
- Always keep your registration card separate from the lock.

Safety Information

- Always secure the caravan against movement (chock the wheels, couple to towing vehicle).
- Never leave Secure parts (key, locking bolt, registration card) in the caravan.
- Always remove Al-Ko Secure before moving the caravan.
- After any attempt at theft has been made on a locked Al-Ko Secure, the caravan must be inspected in an Al-Ko Approved Service Workshop.
- Always keep the key in a safe place.
- Keep the lock set and registration card separate from the keys.
- The lock parts and key do not have a registration number, therefore keep the registration card in a safe place.
- Caravans with twin axles have two locks, keep each lock set in a separate place. The sets are not interchangeable!

Note: Read the operating instructions and act in accordance with them. Keep the operating instructions for general use. Follow the safety instructions as well as the warning information.



ASSEMBLY

We recommend the use of a side-lift jack for easier fitting of Al-Ko Secure when used on a tandem axle caravan. (Order No. Al-Ko Jack Set 1389235).

- Align the wheel so that the receiver can be seen in the centre of the rim opening. DO NOT use the rim opening in which the tyre valve is fitted. (Fig. 1)
- Unscrew the plastic cap from the receiver and store in the tool kit box. (When Al-Ko Secure is not in use, always screw the plastic cap in place). (Fig. 2)
- Insert the locking bolt into the rim specific insert. (Fig. 3)
- Insert the locking bolt socket key. (Fig. 4)
- Line up the locking bolts and assembly with the receiver. (Fig. 5)
- Tighten the locking bolt socket using the wheel spanner provided (or torque wrench as shown) to wheel torque. (Fig. 6)
- Remove the locking bolt socket key. (Fig. 7)
- Insert barrel lock. (Fig. 8)
- Hold the lock fast and lock. (Fig. 9)
- The Al-Ko Secure is now fitted. (Fig. 10)

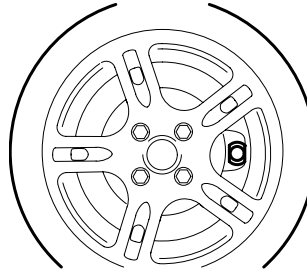

Fig. 1

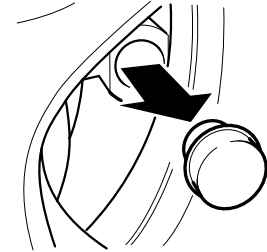

Fig. 2

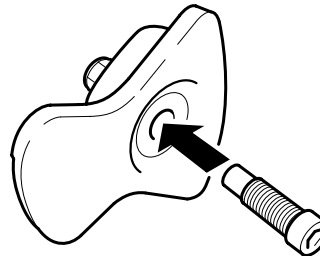

Fig. 3

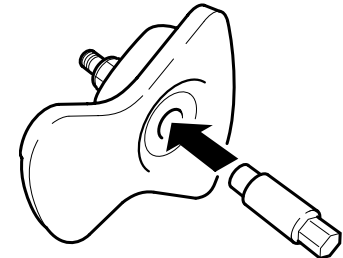

Fig. 4



PREPARING FOR THE ROAD

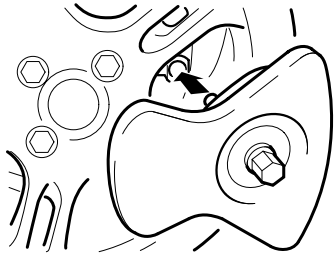

Fig. 5

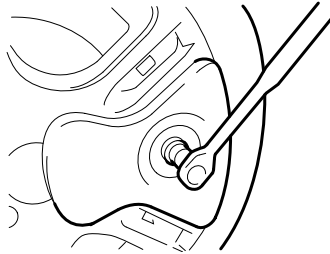

Fig. 6

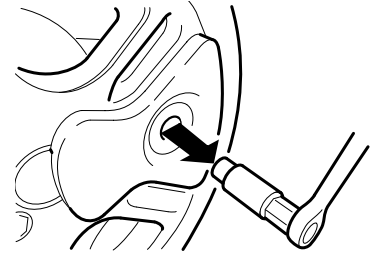

Fig. 7

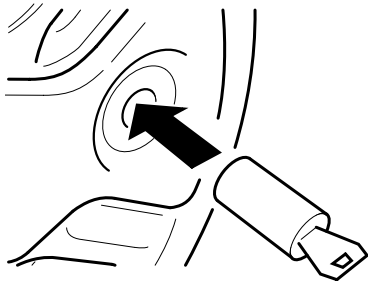

Fig. 8



Fig. 9

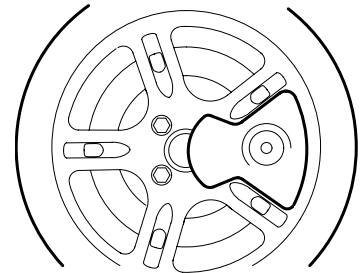

Fig. 10



TWIN AXLE CARAVANS

Fit the front lock first by aligning the wheel so the receiver can be seen in the centre of the rim opening. Chock front wheel and opposite wheel. Jack the caravan (preferably using the Al-Ko side lift jack) until the rear wheel is clear of the ground. Fit the second lock by aligning the wheel as described previously

Note: Lost components phone 0044121 5050400.

In the event of attempted theft report to police and your insurance company.



PREPARING FOR THE ROAD

CORRECT ATTACHMENT OF BREAKAWAY CABLES Braked Trailers (up to 3500kg GVW)

Where a designated attachment point is provided on the towbar:

Either:

- a) Pass the cable through the attachment point and clip it back on itself (Fig 1.)

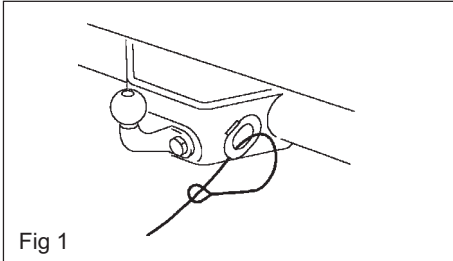

Fig 1

Or:

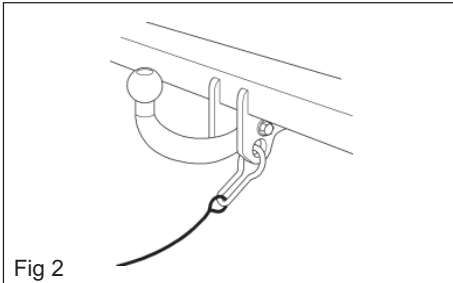

Fig 2

- b) Attach the clip directly to the designated point (Fig. 2). This alternative must be specifically permitted by the trailer manufacturer since the clip may not be sufficiently strong for use in this way.

Where no designated attachment point has been provided on the towbar:

Fixed ball - Loop the cable around the neck of the towball. If you fit the cable like this, use a single loop only. (See Figs. 3 and 4).

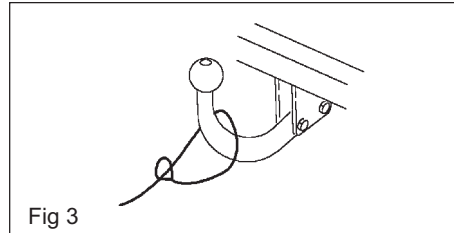

Fig 3

Detachable ball - You must seek guidance on procedure from the towbar manufacturer or supplier.

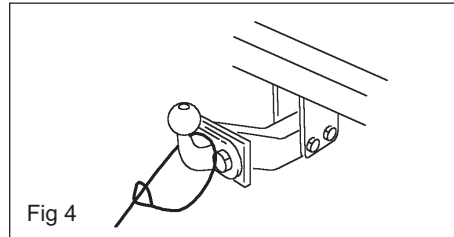

Fig 4

Other means of attachment:

In some instances it may be possible to attach the cable assembly:

Either:

- a) to a permanent part of the towbar structure, as long as this meets the approval of the towbar manufacturer/supplier,

Or:

- b) to an accessory sold for the specific purpose of breakaway cable attachment.

Correct procedure for use:

- Regularly check the cable and clip for damage. If in doubt, contact your dealer or your service agent.
- Make sure the cable runs as straight as possible and goes through a cable guide underneath the trailer coupling.
- Determine whether or not the towbar has a designated attachment point (i.e. a part specifically designed by its manufacturer for a breakaway cable).



When the breakaway cable is attached, check to ensure:

- a) that the cable cannot snag in use on the trailer coupling head, jockey wheel, or any accessory, e.g. a stabiliser, bumper shield, cycle carrier, etc.
- b) that there is sufficient slack in the cable to allow the towing vehicle and trailer to articulate fully without the cable ever becoming taut and applying the brakes.

NOTE: For peace of mind you might wish to check the state of the cable by positioning the trailer and towing vehicle at extreme angles before setting off.

- c) that it is not so slack that it can drag on the ground. If left loose, the cable may scrape along the ground and be weakened so that it subsequently fails to do its job. The cable may also be caught on an obstacle when in motion thus engaging the trailer brakes prematurely.

Having followed this advice, should you feel that a satisfactory coupling arrangement cannot be achieved, consult your trailer or towbar supplier or service agent.

This is the Law

UK Law requires that all trailers with brakes built on or after 1st October 1982 (e.g. caravans, horse boxes, flat bed car trailers etc.) are fitted with a safety device to provide protection in the unlikely event of the separation of the main coupling while in motion. A device referred to as a "breakaway cable" fulfills this requirement and when fitted to a trailer its use is mandatory.

Trailer and/or towbar manufacturers should supply advice on the correct use of these cables. In the absence of such information, the following guidance should be noted.

Purpose of a Breakaway Cable

To apply a trailer's brakes if it becomes separated from its towing vehicle. Having done this, the cable assembly is designed to part, allowing the trailer to come to a halt away from the towing vehicle.

Construction

Usually a thin steel cable, possibly plastic coated and fitted with a means of attachment for connection to the towing vehicle.

Operation

In the event of the main coupling of the trailer separating from the towing vehicle, the cable should be able to pull tight, without any hindrance, engaging the trailer's brakes.

Note: The breakaway cable should never become taut during normal use.

Please see document for full details.
www.thencc.org.uk/downloads/breakawaycable.pdf



PREPARING FOR THE ROAD

WHEELS

Check wheel nut torques regularly and particularly before a long trip for extra safety.

This service is available at all tyre service depots (inform them of the torque settings)

Please see chart on page 11 for torque settings.

- Check wheel/tyres for signs of deterioration or damage.

WARNING: After a wheel has been refitted, always recheck the torque after 20-30 miles use or 20-30 minutes travelling. Even if properly torqued up, it is occasionally possible for fixings to loosen should the wheel "bed in" on the hub.

TYRES

All tyres used on Alaria caravans, when inflated to the pressures recommended, are adequate for speeds up to 130 kph at the maximum specified laden weight of all models.

Note: Maximum permitted speed in the U.K. is 60 mph and in the interests of road safety speeds above this are not recommended.

Tyre tread

A caravan is subject to the same criteria applied to car tyres, namely; a minimum of 1.6 mm tread pattern depth throughout.

Tyre pressures

Caravan and towing vehicle tyres must be at the pressures recommended for towing or heavy loading. The pressures can be found in the towing vehicle handbook and under the caravan specification in the service handbook.

Note: Pressures should only be checked when the tyres are cold, not after a journey or if the vehicle has been standing in the sun.

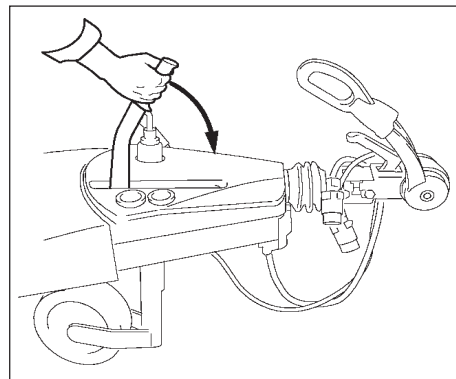

To release the handbrake, push it forward and down using your body weight.

Note: "Failure to ensure that the caravan handbrake is completely off, can result in overheating of the brakes and failure of the bearings".



Ground Clearance

Care has to be taken to prevent grounding of the caravan when traversing ramps and ground obstacles. If necessary ground clearance can be increased by removing the jockey wheel when travelling.

Number Plate

A trailer must carry a rear number plate bearing the number of the towing vehicle and be illuminated at night. The number plate should conform to the same size and colour regulations as for cars. A reflective black and yellow plate may be used on a trailer towed by a vehicle with non-reflective plates and vice-versa.

Manoeuvring

When pushing or pulling the caravan always use the grab handles correctly, do not snatch them and never push body panels, metal or glass reinforced plastics, as this can cause serious damage to the bodywork or mastic seals.

Mirrors

The driver of the towing vehicle must have an adequate view of the rear.

If there is no rear view through the caravan it is essential that additional exterior towing mirrors are fitted.

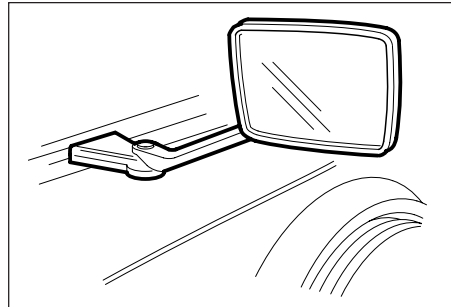

CAUTION: Any rear view mirror must not project more than 200mm outside:

- the width of the caravan when being towed.
- the width of the towing vehicle when driven solo.

Note: Any rear view mirror fitted shall be 'e' marked and cover the field of view as stipulated by type approved requirements (Regulation 33 of the Road Vehicles [Construction and Use] Regulation 1986).



PREPARING FOR THE ROAD

Road lighting

For your information the wiring diagram of the 13 pin connector is shown. These should be checked regularly and if in any doubt a qualified electrician consulted.

Passengers

Passengers are forbidden to ride in a caravan with the exception of authorized test personnel.

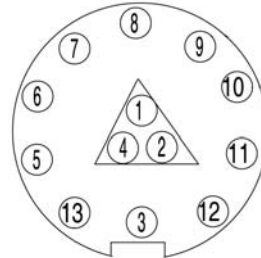

PIN No	COLOUR	DESCRIPTION
1	YELLOW	LEFT IND
2	BLUE	FOG
3	WHITE	NEG FOR ROAD LIGHTS
4	GREEN	RIGHT IND
5	BROWN	RIGHT SIDE LIGHTS
6	RED	STOP
7	BLACK	LEFT SIDE LIGHTS
8	ORANGE	REVERSE
9	BLUE/BROWN	CAR +VE
10	RED/BROWN	FRIDGE +VE
11	GREEN/WHITE	FRIDGE -VE
12	EMPTY	
13	BLUE/WHITE	CAR -VE

13 pin plug wiring diagram



ON THE ROAD

- Speed Limits 26
- Pulling Off 26
- Caravan Handling 26
- Motorway Driving 26
- Reversing 26
- Changing a Wheel 27
- Jacking Points 27
- Stopping on a Hill 28
- Arrival on Site 28
- The E&P Hydraulics Levelsysteem 28



ON THE ROAD

SPEED LIMITS

Normal road towing: 50mph

Motorways (including dual carriageways): 60mph

PULLING OFF

Let the clutch in smoothly.

Allow more engine speed to produce the power to move the additional weight of the caravan.

Avoid wear and tear on clutch and transmission by taking extra care.

Change gears smoothly.

Try not to jerk the clutch.

CARAVAN HANDLING

Allow for caravan being wider than car.

Do not bump kerb with caravan wheels.

When passing other vehicles allow more than the normal clearance for driving solo.

Allow longer to get up speed to pass.

Allow for the vehicle being twice its normal length.

Do not suddenly swing out.

Carry out all manoeuvres as smoothly as possible.

Use nearside wing mirror to check caravan has cleared when overtaking.

Never let a 'tail' of traffic build up behind you. Always pull in to let others past.

MOTORWAY DRIVING

1. Caravans may not be towed in the outside lane of a three or four lane motorway. (Reg. 12(2) of the Motorway Traffic [England and Wales] Regulations 1982).
2. Reduce Speed:
 - i) In high or cross winds.
 - ii) Downhill.
 - iii) In poor visibility
3. High sided vehicles cause air buffeting so extra care must be taken when passing or being passed. As much space as possible should be given.

REVERSING

Proficiency at reversing can only be achieved with practice and should be first attempted in a large open area.

Your caravan is fitted with an automatic reversing mechanism which allows you to reverse without the need to make any adjustments. **After reversing, the caravan should be drawn forward at least 1 metre to restore the brake shoes to their normal position before applying the hand brake.**

Note: Reversing uphill will be difficult if either wheel brake or brake linkage is overadjusted. You need to ensure that the brakes have been disengaged before reversing uphill.

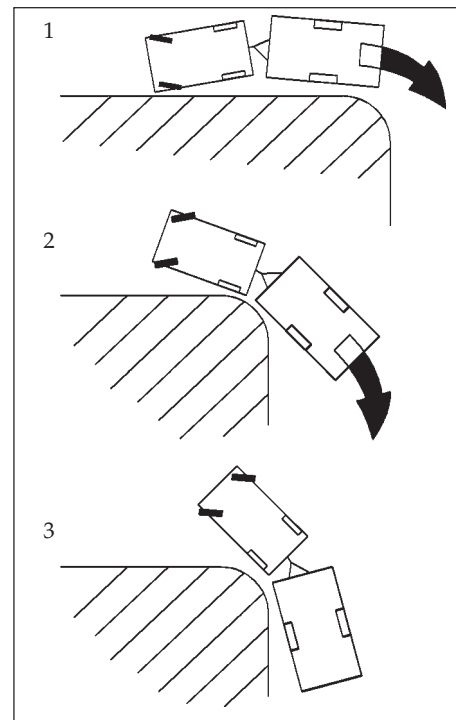

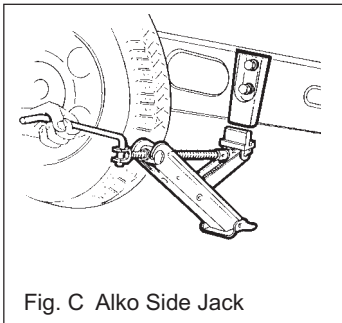
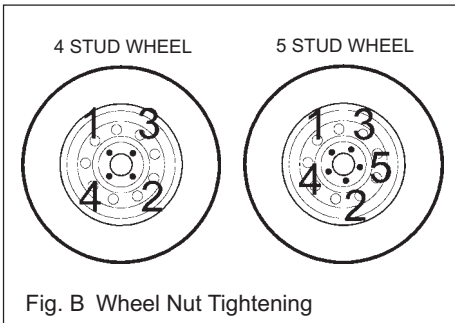
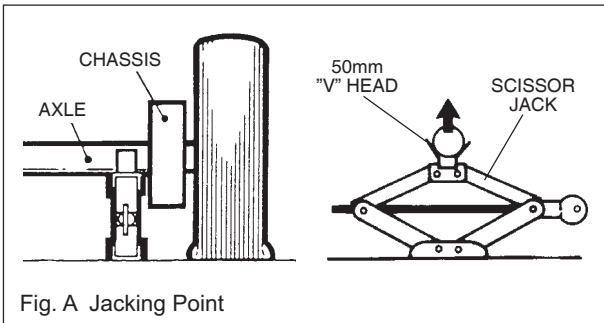

CHANGING A WHEEL

1. Leave caravan hitched to towing vehicle and ensure handbrake is applied.
2. Lower corner steadies (as safety measure) on the side that the wheel is being changed to stabilise the caravan.
3. Use wheel brace to slacken off wheel nuts on the wheel to be changed.
4. Position jack under the axle at the appropriate jacking point (see fig. A).
5. Jack up the caravan until the wheel for removal is just off the ground.
6. Remove the wheel bolts, wheel trims and remove the wheel.
7. Fit spare wheel and reverse the above procedure.

See Preparing for the Road Page 11 for torque settings.

Note: When changing a wheel ensure:

- a) that the correct wheel fixings are used.
- b) that there are clean, dry mating surfaces and clean, dry bolt/nut area.

NB: Special nuts are supplied with alloy wheels and these can be used where a steel wheel is used as a temporary spare.

IMPORTANT

When a wheel has been removed and replaced the torque of the wheel nuts should be re-checked after approximately 15 miles of running.

JACKING POINTS

It is recommended that the jack is located in the correct position i.e. on the axle tube inside the chassis member (Fig. A). The reinforced axle mounting plate can be used as an alternative but the chassis-member itself **MUST NEVER** be used as a jacking point.

Alko Side Jack

The Alko chassis is provided with the facility to fit an Alko side jack which can be fitted as an optional extra (Fig. C).



STOPPING ON A HILL

Pulling off again can sometimes present a problem. The easy solution is:

- (i) Carry a good sized wedge shaped piece of wood with a rope or light chain attached.
- (ii) Attach the other end of the rope to the nearside rear grab handle.
- (iii) Place the wood behind the nearside caravan wheel.
- (iv) Carefully reverse the car slightly back down the hill, the caravan will stop against the wedge and turn.
- (v) Drive forward since this attempt to move up the hill will now not involve pulling the full weight of the caravan until the car has gained some traction.

Ramps

Take care to prevent fouling when traversing ramps or other ground obstacles.

ARRIVAL ON SITE

Note: Check and observe site regulations.

1. Selecting a pitch.

Do not pitch in such a position that your outfit will obstruct others coming in.

Try to choose an area which is dry, reasonably level and preferably with a hard base.

If you have no alternative but to pitch on a slope ensure that, for when you leave, you are facing down the slope.

It is good practice to chock the wheels of the caravan when parked on a slope even though the caravan brakes are applied.

THE E&P HYDRAULICS LEVELSYSTEM

Operation

The E&P hydraulics levelling system is an electrically/hydraulically driven system.

A hydraulic pump is powered by a 12V direct current motor, which will pump hydraulic oil through a system of hydraulic hoses, two hydraulic axle-supports and four hydraulic corner-supports. This with the aim of stabilising and levelling the caravan. Mounted to this pump are the oil reservoir, the valve block and solenoid (magnetic) valves.

The E&P hydraulics level system is electronically controlled by an operating system or so called main unit, which is mounted on a central location in the caravan.

The level system can be operated either fully automatically or manually by means of a built-in control panel and/or (optional) remote control. In most frequent cases the control panel is mounted in the sidewall at the entrance of the caravan.

The jacks have the bearing and levelling capacity your caravan requires. Each axle supports has a 180 mm stainless steel foot plate on a flexible pivot guaranteeing the greatest firmness possible on any surface.

Using the hydraulic levelsystem

The levelling system is only to be used for creating a stable and horizontal position for the caravan.



With the electronic spirit level, the caravan is adjusted horizontally over its complete width with the aid of the two axle supports and the suspension lifted for corresponding stability. Then the caravan is adjusted horizontally in the longitudinal direction with the aid of the four corner supports. The whole caravan will be stabilised with the help of a pressure button on the control panel or on the (optional) remote control.

Specific characteristics of the hydraulic levelsystem

- Automatically extending the jacks from a retracted position.
- Automatically retracting the jacks from an extended position.
- Automatically or manually levelling the jacks.

Operating instructions

Before taking into service, the following points must be observed:

- The noseweight (A) may not exceed the max. 150 kg.
- Make sure that the ground is sufficiently even and that there are no holes and/or other obstructions present.
- Place the caravan on a firm footing, otherwise the axle supports may sink into the ground.

Note: It is important that when you use the system the caravan is standing facing slightly downhill (B).

- Never use the system when there is anything attached to the caravan, such as an awning or a canopy.
- Never use the levelsystem in automatic mode when the caravan is attached to the vehicle

The following safety precautions must be observed when positioning the caravan.

- Apply the caravan handbrake securely.
- Make sure that when the system is being operated, no-one is present in the vicinity of the caravan.
- Do not use any additional supports underneath the axle and corner supports.
- Place no blocks during either manual or automatic levelling.
- Make sure that when levelling is being carried out, on-one is in the caravan.
- An acoustic signal will be sounded during the levelling process.
- The levelling program can be stopped at any time by pressing the ON/OFF button on the control panel or (optional) remote control.

WARNING: Before driving off, check to make sure that all supports have been withdrawn.

Safety warnings

Not observing the following warnings may lead to damages to the caravan and/or serious physical injuries.

- Using the E&P hydraulics levelling system for other purposes than supporting the caravan is officially forbidden according the E&P Hydraulics Limited warranty.
- This product is exclusively developed as a levelling system and may not be used for other work under the caravan such as changing the tyres.

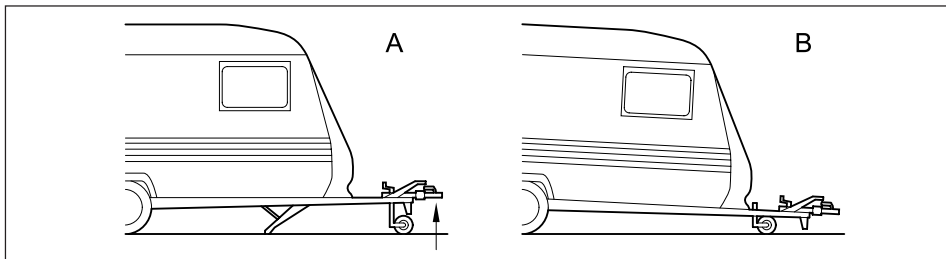



ON THE ROAD

- When the system is operating, all persons and animals should keep their distance.
- Body parts (e.g. hands and eyes) should never come into contact with released fluids. Oil leaving the hydraulic levelling system may be under high pressure and could cause serious injuries to the skin. Consult a doctor immediately in case of accidents.
- The caravan should be parked on a solid, level and non-slippery surface. The parking location must be free of holes of waste and surrounding objects.
- If the caravan is parked on very soft soil, you must place a support plate under each jack in order to distribute the weight.
- Check if the installation of the hydraulic levelling system is performed by a skilled mechanic with sufficient practical experience and technical E&P hydraulics training.
- In case of repairs/malfunctions to the hydraulic levelling system: know what you are doing. Never try to repair it yourself, but consult your installer or dealer.
- Fully read this user manual, before using the hydraulic levelling system.
- After deploying the hydraulic levelling system ALWAYS make an inspection tour around the caravan. Just to be sure the caravan stands stable (all hydraulic jacks are on the ground).

Control functions

Functions on the control panel

The diagram below shows the appearance of the control panel. By using the control panel (or remote control) you can operate the hydraulic levelling system.

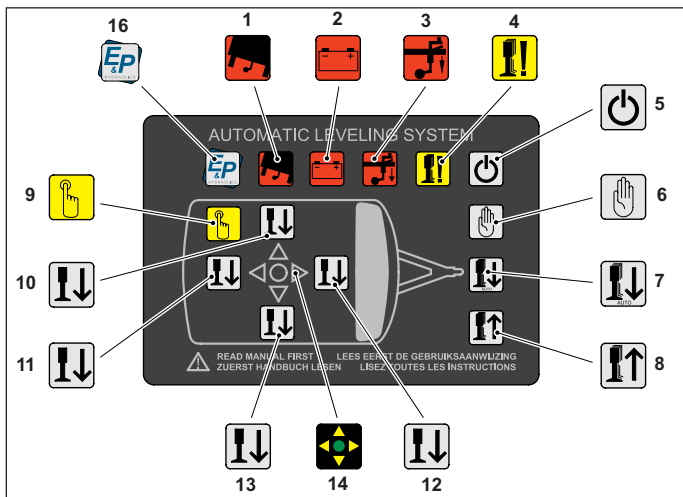

Function declaration:

- | | |
|--------------------------------------|---------------------------|
| (1) LED: Slope too steep | (9) LED: Manual mode |
| (2) LED: Battery low voltage | (10) Button: Left side |
| (3) LED: Withdraw front wheel | (11) Button: Rear side |
| (4) LED: Jacks not (fully) retracted | (12) Button: Front side |
| (5) Button: ON/OFF | (13) Button: Right side |
| (6) Button: Manual mode | (14) LED: Level indicator |
| (7) Button: Automatic mode | (16) LED: E&P logo |
| (8) Button: Retract all Jacks | |



Functions

The diagram below shows the appearance of the remote control. By using the remote control you can operate the hydraulic levelsystem.

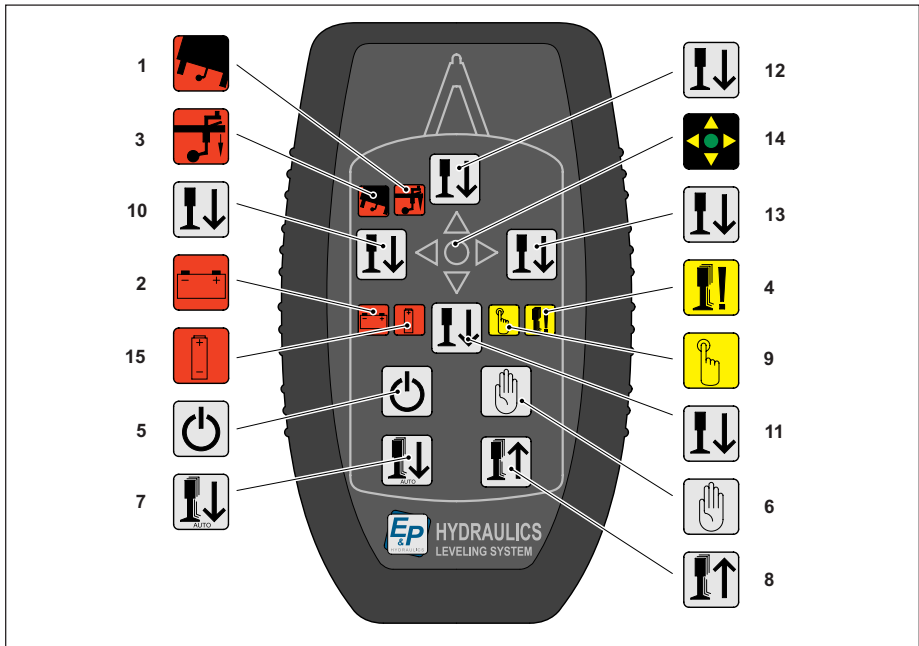









Function declaration:

- | | |
|--------------------------------------|---------------------------|
| (1) LED: Slope too steep | (9) LED: Manual mode |
| (2) LED: Battery low voltage | (10) Button: Left side |
| (3) LED: Withdraw front wheel | (11) Button: Rear side |
| (4) LED: Jacks not (fully) retracted | (12) Button: Front side |
| (5) Button: ON/OFF | (13) Button: Right side |
| (6) Button: Manual mode | (14) LED: Level indicator |
| (7) Button: Automatic mode | (15) LED: E&P logo |
| (8) Button: Retract all Jacks | |







ON THE ROAD

Extensive function declaration

- | | | | |
|------|--|------------------------------------|---|
| (1) |  | SLOPE TOO STEEP | In this position the caravan cannot be levelled (the surface is not even enough) If necessary switch over to manual mode. |
| (2) |  | BATTERY LOW VOLTAGE | The battery is empty or the voltage is too low to be able to work safely. |
| (3) |  | WITHDRAW FRONT WHEEL | The caravan is too high at the front, withdraw the front wheel and the LED will go out. |
| (4) |  | JACKS NOT (fully) RETRACTED | One or more jacks are extended or not fully retracted. |
| (9) |  | MANUAL MODE | Indicates that the caravan can now be brought to the correct level manually. |
| (14) |  | LEVEL (zero point) | Indicates that the caravan can now be brought to the correct level. |
| (15) |  | BATTERY 9V VOLTAGE | The battery voltage of the remote control is too low (only present on the remote control) |
| (16) |  | E&P LOGO | Indicates that the levelsystem is switched on (only present on the remote control) |

BUTTONS

- | | | | |
|------|--|--------------------------|---|
| (5) |  | ON/OFF | Switches the levelsystem on or off. |
| (6) |  | MANUAL MODE | Switches the levelsystem into manual mode for levelling the caravan. |
| (7) |  | AUTOMATIC MODE | Switches the levelsystem into automatic mode for levelling the caravan. |
| (8) |  | RETRACT ALL JACKS | Automatically retracts all jacks. |
| (10) | | LEFT SIDE | Controls retracting and extending the left jacks. |
| (11) | | REAR SIDE | Controls retracting and extending the rear jacks. |
| (12) |  | FRONT SIDE | Controls retracting and extending the front jacks. |
| (13) | | RIGHT SIDE | Controls retracting and extending the right jacks. |









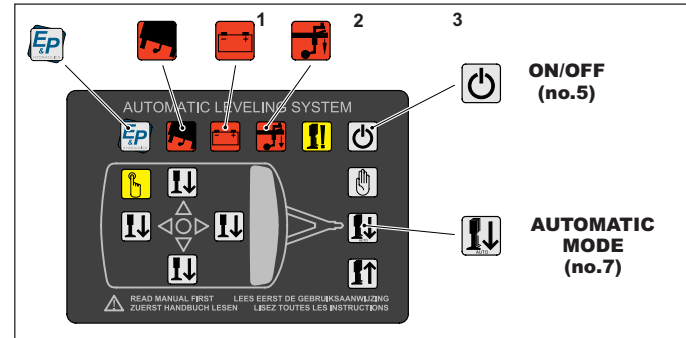

Operating the levelsystem

Automatic levelling

Procedure for automatic deployment/extension of the axle and corner supports.



-  **Step 1** Press 1x on the button ON/OFF (no.5) to switch the levelsystem ON.
-  The E&P-logo LED lights up, indicating that the levelsystem is switched on.
 -  When there is insufficient or no battery voltage, the indicator LED “LOW VOLTAGE” (no.2) lights up.
 -  In automatic levelling, the caravan must be tilted a few degrees forwards. The system will indicate whether you have positioned the caravan level enough. If you have not, the indicator LED “FRONT WHEEL” (no.3) lights up and the system cannot be started automatically. The front wheel must be wound down.
 -  When the caravan leans too steeply, the indicator LED “SLOPE TOO STEEP” (no.1) lights up.
REMARK: When the caravan stands too skewed, the caravan cannot be automatically levelled. You now have two options: Stop the levelling procedure and place the caravan on a flatter surface and start again with automatic levelling procedure. Or go further with manual levelling procedure.
-  **Step 2** Press 1x on the button “AUTOMATIC MODE” (no.7) to start the automatic levelling procedure.
-  When the levelling procedure is complete, the indicator LED “LEVEL” (no.14) lights up GREEN.
REMARK: Depending on the angle of the terrain and type of caravan, the automatic levelling procedure takes about 1 minute.
-  **Step 3** Press 1x on the button “ON/OFF” (no.5) to switch the levelsystem OFF.



ON THE ROAD

Manual levelling

In below the procedure for manual deployment/extension of the axle and corner supports.

The manual levelling function is mainly used when automatic levelling is not possible due to a large tilt of the caravan. With the help of this feature it is also possible to change the position of the caravan; think of your sleeping comfort. Most people prefer to sleep with their head up slightly. Depending on the orientation of the caravan with this feature you can manually adjust the angle where necessary.

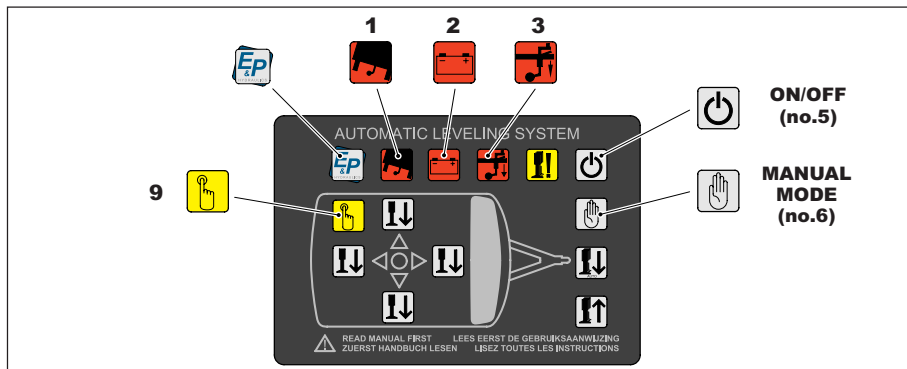

Step 1 Press 1x on the button ON/OFF (no.5) to switch the levelsystem ON.

The E&P-logo LED lights up, indicating that the levelsystem is switched on.

When there is insufficient or no battery voltage, the indicator LED “LOW VOLTAGE” (no.2) lights up.

In manual levelling, the caravan must be tilted a few degrees forwards. The system will indicate whether you have positioned the caravan level enough. If you have not, the indicator LED “FRONT WHEEL” (no.3) lights up.

Step 2 Press 1x on the button “MANUAL MODE” (no.6).

The indicator LED “MANUAL MODE” (no.9) lights up, indicating the manual levelling procedure may begin.

When the caravan leans too steeply, the indicator LED “SLOPE TOO STEEP” (no.1) lights up, although this LED lights up, you are able to level. On the side where the caravan is low, fill the space under the axle support (footplate) with some boards to compensate the difference in height. This will avoid the risk it is not possible to level the caravan due to a too large difference in height. In case of too large height difference the hydraulic jacks may come to the end of their stroke.



Step 3 In most common cases, there lights up one ORANGE arrow on the control panel (no.14) which indicates on which side the caravan has to be lifted.

Before lifting this side, FIRST lower the other axle-support till it touches the ground.

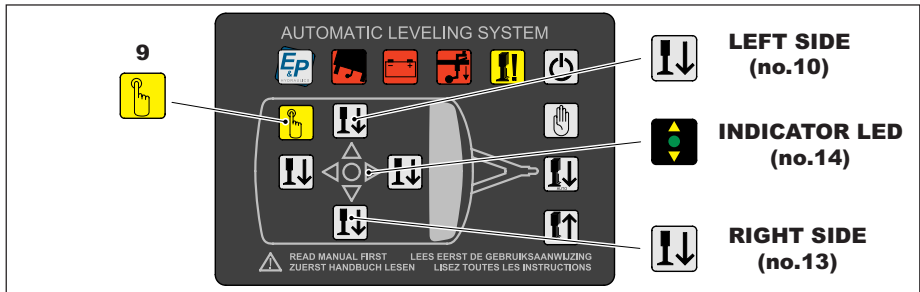

Then the other axle support can be extended by holding button “LEFT SIDE” (no.10) or “RIGHT SIDE” (no.13) pressed down. The levelling procedure automatically stops when the caravan is levelled in the left right direction. The ORANGE arrow level LED (no.14) goes out.



-  **Step 4** Press the button “FRONT SIDE” (no.12) and hold it pressed down till the ORANGE arrow level LED (no.14) goes out, extending of the front corner supports stops by itself when the caravan is levelled in the front to rear direction.
-  **Step 5** Press the button “REAR SIDE” (no.11) until the corner supports at the rear side are touching the ground.
Attention: The level system does NOT stop automatically.
-  **Step 6** Press 1x on the button “ON/OFF” (no.5) to switch the levelsystem OFF.

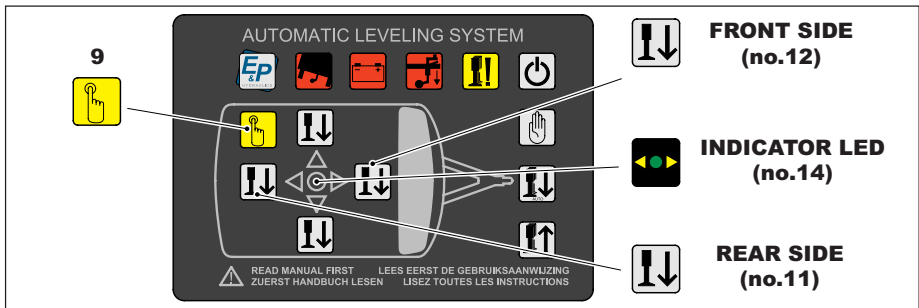



ON THE ROAD

Retracting the jacks

Follow the procedure below to retract the axle and corner supports.



Step 1

Press 1x on the button "ON/OFF" (no.5) to switch the levelsystem ON.



The "E&P-logo" LED lights up, indicating that the levelsystem is switched on.



Step 2

Press 1x on the button "RETRACT ALL JACKS" (no.8) once.



The indicator LED "JACKS NOT FULLY RETRACTED" (no.4) goes out when all jacks have been fully retracted.



Step 3

Press 1x on the button "ON/OFF" (no.5) to switch the levelsystem OFF.

IMPORTANT: Before departure ensure all supports have been retracted.

Extra functions

Calibration (setting the zero point)

The calibration procedure described below has already been carried out at your dealer/installer.

You don't have to perform this procedure by yourself. E&P Hydraulics has decided to include this chapter as an extra in this manual in case of failure and/or service & repair matters.

Consider setting the zero point** as a condition to make it possible to level the caravan automatically and/or manually. When this operation, for some reason, has not been done or has been carried out incorrectly, it is not possible to level the caravan.

**The zero point is the point (level) at which the hydraulic levelling system (in an automatic cycle) returns.

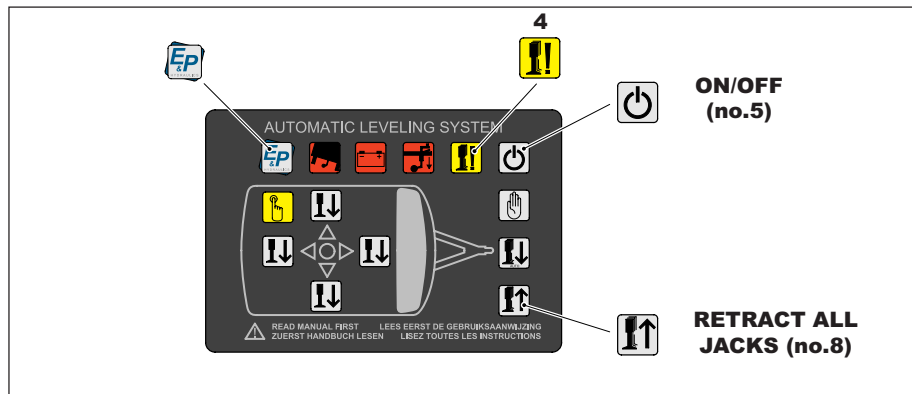



Start: Manual levelling

Before automatic levelling can be activated, you must set the zero point. For setting the zero point, you must FIRST perform the manual levelling procedure.

REMARK: Do this by placing a spirit level in the centre of the caravan.

ATTENTION! Never put the rear brackets first to the ground. This in case creating too much load on the caravan.

Setting the zero point

Step 1 Press **1x** on the button “ON/OFF” (no.5) to switch OFF the levelling system after manual levelling.

Step 2 Press **1x** on the button “ON/OFF” (no.5) to switch the levelling system ON.

Step 3 Press **5x** on the button “FRONT SIDE” (no.12)

Step 4 Press **5x** on the button “REAR SIDE” (no.11)
All LED's on the control panel light up. (the vehicle stands in zero mode)

Step 5 Press **3x** on the button “RETRACT ALL JACKS” (no.8)
The zero point is programmed.

Step 6 Press **1x** on the button “ON/OFF” (no.5) to switch the levelling system OFF.

Remote control (optional)

Preface

The procedure described below has already been carried out at your dealer/installer.

Consider programming (setting) the remote control as a condition to make it possible to level the caravan automatically and/or manually. When this operation, for some reason, has not been done or has been carried out incorrectly, it is not possible to level the caravan with the remote control.

Antenna

Check if there is an antenna connection on the operating system (see below). If this is not the case, the remote control CANNOT communicate with the hydraulic levelling system. In principle, the antenna connector and the antenna are always present when you purchase the levelling system including a remote control unit.

If you purchased the remote control at a later stage, then you should remember that this antenna connection on the operating system (main unit) could be missing.

The presence of the antenna is dependent on the acquisition period of the levelling system. After 2013, all operating systems have this antenna connector. In this case, the dealer/installer can directly connect the antenna to the operating system (the antenna is supplied with the remote control)



ON THE ROAD

Operating system including the antenna connection

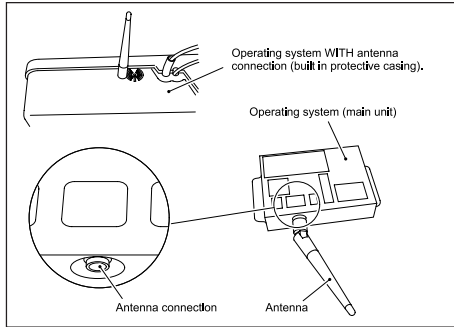

Battery

Remove the battery cover on the rear side of the remote control by firmly pressing the cover and then sliding out. Insert the 9V battery carefully reassemble the battery cover (in most common cases the battery is already fitted).

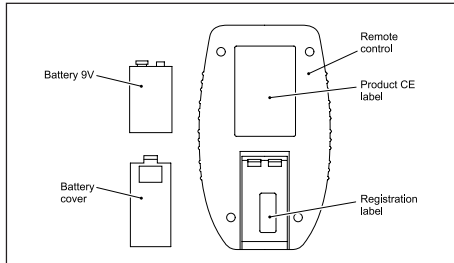

Programming the remote control

Step 1 In order to pair the remote control to the system, remove the fuse (30 Amp) out of the cable assembly from the hydraulic levelsystem.

Step 2 Press the buttons "AUTOMATIC MODE" (no.7) and "RETRACT ALL JACKS" (no.8) simultaneously.

When done, the Indicator LED (no.14) with the surrounding 4 arrows starts blinking GREEN/ORANGE rapidly. This means the remote control is looking for its receiver, mounted within the operating system.

Step 3 Reconnect the fuse to the system.

- The pairing process should be made within a certain time (approx. 20 sec)
- The remote control turns off automatically.
- When the Indicator LED (no.14) goes off, the pairing process is complete.

Putting the remote control into use

After programming the remote control you now have the possibility to operate the levelsystem with the remote control.

Step 1 Switch the remote control ON by pressing button "ON/OFF" (no.5) for at least 1 second. Now the GREEN LED will light up by flashing. As long as you see this LED flashing, the remote control is searching for contact with the operating system. When contact is made the flashing stops.

The illumination of one or two ORANGE arrows on the indicator LED (no.14) central on the control panel shows the position of the caravan.

In the unlikely event that the caravan is already level, then the indicator LED (no.14) lights up GREEN.



Which device takes command

The device which is switched on first (remote control or control panel) takes the command to control the system, until that device is switched off. If you would like to switch from one control device to another, you need to switch off the power from the device that was in operation first.

REMARK 1: In the event of switching over from the remote control to the control panel: you have to wait a little time, to give the system enough time to switch off contact between the remote control and the operating system.

REMARK 2: It may be that the operating system is built in such a way that receiving a signal between the remote control and the operating system works poorly or even not at all (caused by caravan construction materials e.g. steel, wood, plastics etc).

In this case there is a possibility to move the antenna away from the operating system by means of an optional extension cable (length max. 2 metres, available from E&P Hydraulics).

Battery Indicator

When the battery level indicator LED (no.15) lights RED, the device does not stop working immediately. After this signal it is possible to use the remote control approx. another 4 times. Make sure there is a spare battery in the caravan.

Emergency pump

Introduction

The optional Emergency Hand pump allows the levelsystem to be operated manually, in the (emergency) event the system is defective, or (more likely) because there is not enough battery voltage present.

This possibility is offered by E&P Hydraulic for situations where, for whatever reason, the levelsystem does not withdraw its support jacks and is therefore preventing you from driving, or moving the caravan.

We call it an "emergency situation" because in practice the time of withdrawing the hydraulic jack is, most often, also the time of a (planned) departure. By not automatically withdrawing the support jacks you can no longer move, with adverse consequences.

Therefore, E&P Hydraulics offers you the possibility to integrate an emergency hand pump, for the levelsystem. As the name implies, it is a pump operated by hand that controls (the withdrawal of) all jacks. This means that the time of your departure, transport or movement can be guaranteed.

The emergency hand pump is mounted under the caravan in such a way that it is accessible from the side.P

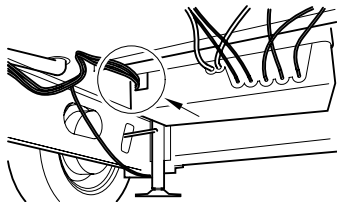

Protective pump housing with the connections to the emergency pump.

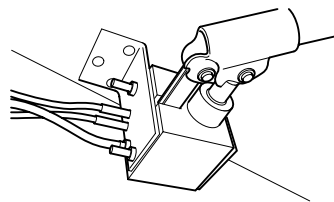

Emergency hand pump



ON THE ROAD

Putting the Emergency pump into use

When actually using the emergency hand pump operation, proceed as follows:

- Step 1** Using the allen key, turn the gold hexagon bolt on the emergency hand pump clockwise to the right (open position).
- Step 2** Place the metal tube (handle) into the black holder on the emergency hand pump assembly.
Pump (back and forth) with the metal tube until all hydraulic jacks are withdrawn.
(all jacks will be withdrawn at the same time)
- The moment you feel pressure (resistance) building up during this movement is the sign the jacks are fully withdrawn.
- Step 3** Remove the metal tube from the holder.
- Step 4** Using the allen key, turn the gold hexagon bolt on the emergency hand pump assembly carefully to the left until it locks (closed position).

Attention: carefully turn the lock (closed) position.

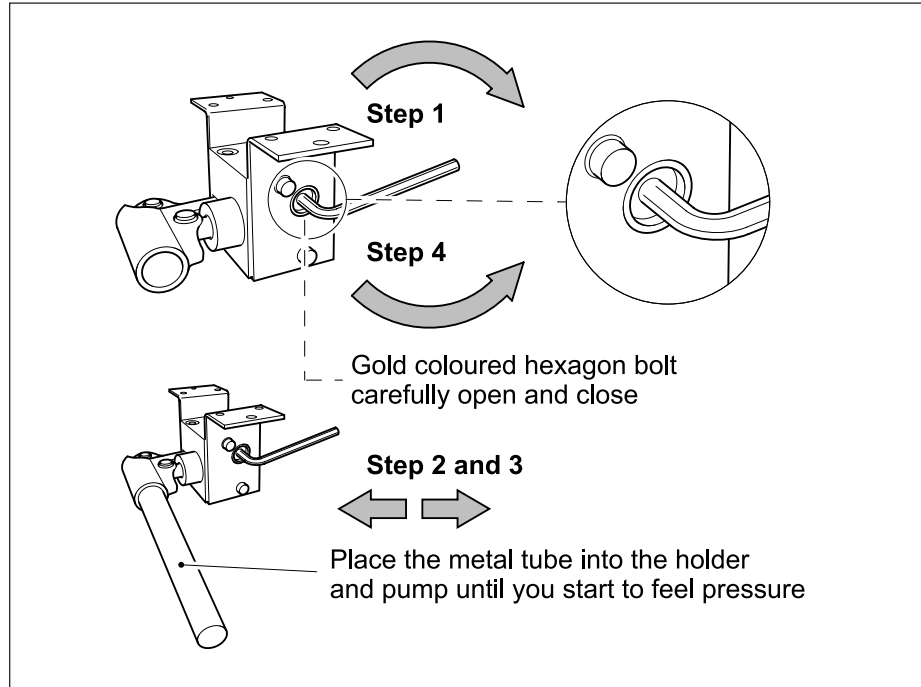

Schematic diagram of the hydraulic levelsystem

Below the schematic view/diagram of the E&P Hydraulics levelsystem.

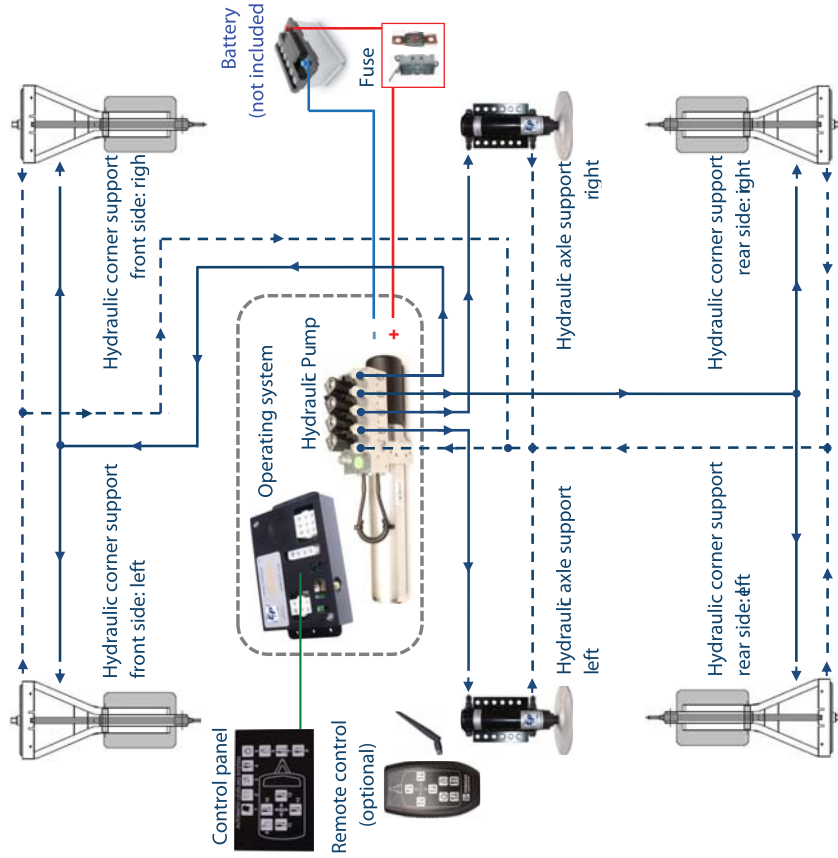



Remarks and recommendations

Below is an overview concerning remarks and recommendations (tips) of the hydraulic levelling system:

- After 4 minutes of no operation, the system will switch off automatically.
 - The automatic levelling cycle can only be started after all jacks have been retracted. If the jacks are not retracted when the automatic cycle starts, the system will do this automatically. So it is not possible to make short adjustments to the jacks; the system will always first completely retract its jacks.
 - At a low battery voltage, the system will automatically switch off.
 - Jacks are extended and you accidentally drive off: the system will immediately give an alarm and the jacks are automatically retracted as soon as the handbrake is disengaged. In case of vehicles with a pneumatic brake installation, this takes place when the engine is started.
 - All normal functions of the system are switched off in error mode.
- The jacks always operate 2 at a time at 1 side. The left side, right side, front side and rear side. Only when retracting do they operate all 4 at the same time.
 - During winter conditions (e.g. in snow and ice) put something (e.g. a piece of carpet) under the jacks to avoid sliding.
 - Manual operation is mainly recommended for uneven surfaces.
 - In manual operation, all four jacks should always be extended before levelling starts.
 - The system cannot handle all angles, the limit values differ per caravan.
 - If the system makes a slope angle that is too big and no longer responds to requests for automatic levelling, we recommend bringing the vehicle as close as possible to the zero point in manual mode.



Troubleshooting

In case of an error message, check the caravan stands are not too high at the front (front wheel must be withdrawn), whether the battery has sufficient voltage, whether the oil level is correct, whether there is any damage to the jacks, and check all the cables.

If this does not lead to a solution for the fault, the fault could be located in the drive units. As the drive unit does not have any repairable parts, you should contact your E&P Hydraulics dealer/installer.

Under normal circumstances, all LED's are off and the unit will only respond by pressing the button "ON/OFF" (no.5) switching the levelsystem on.

Problem	Possible Causes	Solution(s)
The system fails to start	Battery voltage low.	Recharge the battery, Charger is defective or there is no voltage being supplied.
The red battery lamp lights up. When the red battery lamp lights continuously, the installation is switched off for 4 minutes.		
The support jacks do not extend towards the ground when the pump is running.	Oil level too low or no oil in the system. The pump is not working correctly. There is no or bad electronic connection.	Check for any oil-leaks Repair or exchange. Check cables for loss of voltage.
The system does not work automatically, lamp front wheel lights up. **NOTHING works, even no LED signal.	Caravan stands too high on the front side. Possible cause: the battery is fully out of order (<5V).	Withdrawn the front wheel

IMPORTANT: For all other reports and/or malfunctioning of the system, please contact your dealer/installer.



Maintenance

The E&P Hydraulics levelsystem does not have parts that need to be maintained periodically. When parts have been taken apart, the warranty will become invalid. If necessary, parts could be substituted, repaired and/or exchanged (warranty).

WARNING: In control/service work secure the caravan by placing suitable stands under the caravan. By not doing this you create a real danger of personal injury or serious accident.

Preventative Controls

- Periodically checking the hydraulic oil level. (ONLY by dealer/installer)
 - The hydraulic oil (type: Pentosin CHF 11S) preventative replace after approx.. 36 months.
- Periodically check the electronic cables and connections.
- Periodically check the hydraulic jacks.
 - Remove dirt, sand, mud and other contamination that settles during use, it may obstruct the operation of the hydraulic levelling system.
 - If the jacks remain extended for a longer period of time, the exposed legs must be protected by weekly spraying them with a silicon lubricant. Do this every 2 or 3 days, if the caravan is located in a salty environment.

- In winter (slippery) conditions we advise you to take additional safety and precautionary measures. Especially because your safety during operation of the system. For optimal performance under extreme conditions (-30 degrees) we recommend the use of a special hydraulic oil for low temperatures (consult an authorized dealer).

Furthermore, during the winter period we have to deal with situations in which de-icing salt will tack to the outside of the system.

Preventative maintenance should be:

- Good cleaning of the jacks.
- Clean the stainless steel cylinder (piston rod) and spray with a silicone lubricant.
- Remove dirt from the stainless steel foot plate (especially at the bottom, this is the area your caravan stands on)
- Try to put the caravan in a location as clean and flat as possible.
- Place a piece of rubber (e.g. piece of carpet) between the frozen (slippery) surface and the footplate.
- Before leaving make an additional check round the caravan, if necessary remove snow and ice from the jacks, then you are free to withdraw the jacks.

Warranty

Repairs to the caravan must be performed by dealers recognized by E&P Hydraulics. For systems which are not (or cannot be) changed, installed or repaired by a recognized E&P Hydraulics dealer, the warranty cannot be used.

E&P Hydraulics gives guarantees for parts of its hydraulic levelsystem against faults in material and manufacturing for a period of 24 months starting from the date of purchase. If an E&P Hydraulics product was checked by an official E&P Hydraulics dealer and a fault in material or manufacturing was discovered within the aforementioned period, E&P Hydraulics is able to choose the following actions:

- Repairing or replacing the faulty part for free in E&P Hydraulics factory or another location determined by E&P Hydraulics.
- Sending a mechanic to the location where the caravan is at that moment, in order to repair or replace the product/part on site.
- Writing out a credit note for the defective product/part.



All warranty claims require a product test and approval by (a dealer of) E&P Hydraulics. All repairs must be approved by E&P Hydraulics before the work starts. There can be no exceptions to this procedure. Immediately contact E&P Hydraulics directly before trying to perform a repair or change to your E&P Hydraulics product. Claims for alleged damages to products are only allowed if E&P Hydraulics has had the opportunity to check the claim.

The warranty becomes invalid when:

If the buyer modifies the system, or if the buyer makes settings independently. In case of abuse or negligence, overloading, damage through accident, incorrect loading or incorrect weight distribution, damage through improper use or improper maintenance, connection to wrong parts or repair attempts by other persons than the acknowledged E&P Hydraulics dealer/installer.

This warranty does not apply to physical damage, damage as a result of force majeure, in case of commercial use or adaptation of the product or for products that are sold as a special offer and/or 'with defects'.

This warranty will become invalid if the product's identification criteria, which were attached in the factory, are changed or removed.



**FIRE
&
SAFETY**

- In Case of Fire 48
- Smoke Alarm 48
- Carbon Monoxide Alarm 49
- Fire Extinguisher 49
- Children 49
- Ventilation 50
- Security 50
- Theft 50



FIRE & SAFETY

FIRE ACTION

1. GET EVERYONE OUT
2. TURN OFF GAS VALVE
3. RAISE THE ALARM AND CALL THE FIRE BRIGADE
4. DISCONNECT THE MAINS ELECTRICITY SUPPLY
5. TACKLE THE FIRE IF SAFE TO DO SO
6. MAKE YOURSELF FAMILIAR WITH THE INSTRUCTIONS ON YOUR FIRE EXTINGUISHER AND THE FIRE PRECAUTION ARRANGEMENTS ON THE SITE
7. CHECK FIRE EXTINGUISHERS REGULARLY
8. CHECK GAS PIPING AND MAINS ELECTRIC WIRING ANNUALLY

If you suspect a gas leak - never use a naked flame to search - always use soapy liquid or - better still - call your caravan dealer.

Important

With any extinguisher, never use it on a pan of fat - this is very dangerous - always use a fire blanket.

To tackle a pan fire: First of all, if possible try to turn off the gas. Make sure you are aware of the position of the gas isolating taps - usually placed in the sink unit cupboard.

Never throw a flaming pan outside, keep your hands away from the flames and smother the flame.

Try to remain calm.

Do not throw the blanket on the fire but place over the pan paying particular attention to the handle.

Fire Precautions

Make sure you are aware of the operation and location of escape windows and doors.

It is advisable to carry a fire extinguisher (a dry powder is recommended) positioned as near to the exterior door as possible.

A fire blanket approved to BS 6575 is also advisable positioned as near to the cooking area as possible.

Check the fire regulations on arrival at sites. Do not leave pans on the stove unattended. Do not leave matches within easy reach of small children.

Never leave small children alone in the caravan.

Do not smoke in bed.

Do not block up ventilators.

SMOKE ALARM

The Code of Practice requires that a smoke alarm is fitted in your caravan. Every new manufactured caravan has a smoke alarm fitted as standard equipment.

Connecting the battery

Your alarm requires one 9 volt battery to power the smoke detector portion of the unit. Under normal use, the battery powering the smoke detector should last approximately one year. See label inside smoke alarm lid for suitable batteries.

With a pencil, write the date of battery installation on the inside of the cover to remind you when to replace the battery.

Lift battery from battery holder and snap battery connectors to battery. They fit together only one way.

Gently push battery into battery holder.

To close the cover match up snap-in hinges and gently press together until base and cover snap together.

IMPORTANT: When the battery is first connected the alarm may sound for 2-3 seconds.

THIS IS NORMAL.

It means the battery is connected correctly.

Replacing the battery

Test the alarm for correct operation using the test button whenever the battery is replaced.

When battery power is low and replacement is necessary, the alarm will 'beep' about once per minute for at least 30 days. The battery must then be replaced. Replace battery if the



alarm does not sound when the test button is pressed. For maximum reliability, replace battery at least once a year.

Testing the Smoke Alarm

It is recommended that you test the smoke alarm once a week to be sure the unit is working. It will also help you and your family to become familiar with the sound of the alarm.

When you press the test button it simulates the effect of smoke during a real fire. So, there is no need to test the alarm with smoke.

Press and hold the test button until the alarm sounds (it may take up to 10 seconds). The alarm will stop sounding shortly after the button is released.

Cleaning the Smoke Alarm

Clean the smoke alarm regularly. Use a soft bristle brush or the brush attachment of your vacuum cleaner to remove dust from the sides and cover slots where the smoke enters. Keep cover closed while cleaning. Do not vacuum or brush inside the smoke alarm. To clean the cover, remove it completely and use only mild soap and water. Dry cover thoroughly before replacing it.

WARNING: Do not paint the Smoke Alarm.

Other than the maintenance and cleaning described above, no other customer servicing of this product is required.

CARBON MONOXIDE ALARM

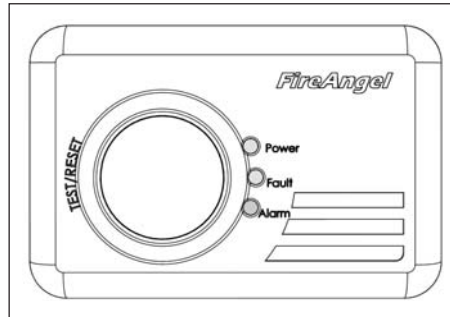

Your carbon monoxide alarm is located on the underside of the offside or nearside locker. Under normal operating conditions the power pack will last for the lifetime of the product (7 years). Batteries for this product are non replaceable.

It is recommended that the alarm is tested weekly by pressing the test/reset button.

LED Indicators

Power. In normal operation the LED will regularly flash green.

Fault. If a fault is found in the sensor and circuitry or the power pack becomes low then the detector will emit a single chirp once per minute and the fault LED will flash yellow once per minute for 30 days.

Alarm. When sufficient carbon monoxide is detected a loud audible signal will be emitted and the alarm LED will flash red once every second. When alarm is tested the LED will illuminate red.

FIRE EXTINGUISHER

It is recommended that a 1kg (2lb) minimum capacity dry powder fire extinguisher be carried inside your caravan at all times. (NCC recommend types marked 5A34B).

When using a dry powder extinguisher it is suggested that the caravan be evacuated until the powder has settled, to avoid inhalation.

A fat pan fire should not have a fire extinguisher aimed at it. It should be smothered with a fire blanket.

Children

Do not leave children alone in the caravan in any event. Keep potentially dangerous items out of reach, as at home e.g. matches, drugs etc.

Bunks

Where fitted, the foldaway bunk has been tested to 70kg (11 stones) and has a recommended limit of 57kgs (9 stones). Safety features are included but care should always be taken, particularly if the child is under 3 years of age. Bunks are not suitable



FIRE & SAFETY

for children under 6 years old without supervision.

Solid (fixed) bunks have a recommended limit of 75kg (12 stones).

Ventilation

All caravans comply with British Standards EN1645. The ventilation points on your caravan are fixed points of ventilation which are stated by the British Standards. Ventilation is provided at floor and ceiling level and care should be taken to ensure these remain clear of debris by regular cleaning.

Under no circumstances must these vents be blocked or obstructed.

It is advised that fixed ventilation points are checked and cleaned (if necessary) on a regular basis.

Additional night time ventilation is obtained by releasing the window catches and placing them in the second groove on the frame catch.

You must maintain adequate spacing of combustible materials from sources of heat (eg heater)

Do not use independent gas appliances inside the caravan.

We advise that the user instructions for the fitted appliances are studied in addition to the information in this handbook.

Petrol/Diesel Fumes

The fitting of a tail pipe to your car exhaust will reduce the possibility of fumes entering your caravan through the front fixed ventilation points.

SECURITY

Caravan theft

The theft of a caravan can occur in the most unlikely circumstances; from a motorway service area, even from an owner's driveway.

Secure all windows and doors when your caravan is unoccupied even if only for a short length of time.

Please see General Data for CRIS information.

Additional security

Consider fitting any device which might deter or prevent intrusion by thieves.

A hitch lock cover helps to prevent towing of the caravan.

A wheel lock prevents towing of the caravan and removal of the wheel.

Customers are advised to identify their caravan with a method for subsequent identification if other forms of identification have been altered or removed.

Datachip Security Card

Each model has a datachip security card concealed within the body of the caravan, showing the VIN.



SERVICES

Water	52
Gas	59
Electricity	64



SERVICES

WATER SYSTEM

An underfloor water tank with an approximate capacity of 40 litres of fresh water is fitted as standard equipment. Water levels are displayed by a series of LED's on the control panel. The tank has its own in-built pump and filling of the tank via the external pump supplied, which is operated by a switch on the control panel.

Full switching operation for the pumps can be found under the control panels.

Due to weight and stability we recommend that the tank is drained prior to towing.

DO NOT ALLOW ANY OF THE PUMPS TO BE ACTIVATED WHEN NO WATER IS PRESENT AS THIS WILL DAMAGE THE PUMP.

The tank is fitted with an overflow and a drain cock.

Do not use bleach or detergents for cleaning the system but rather a formulation from your chemists normally used by home brewers.

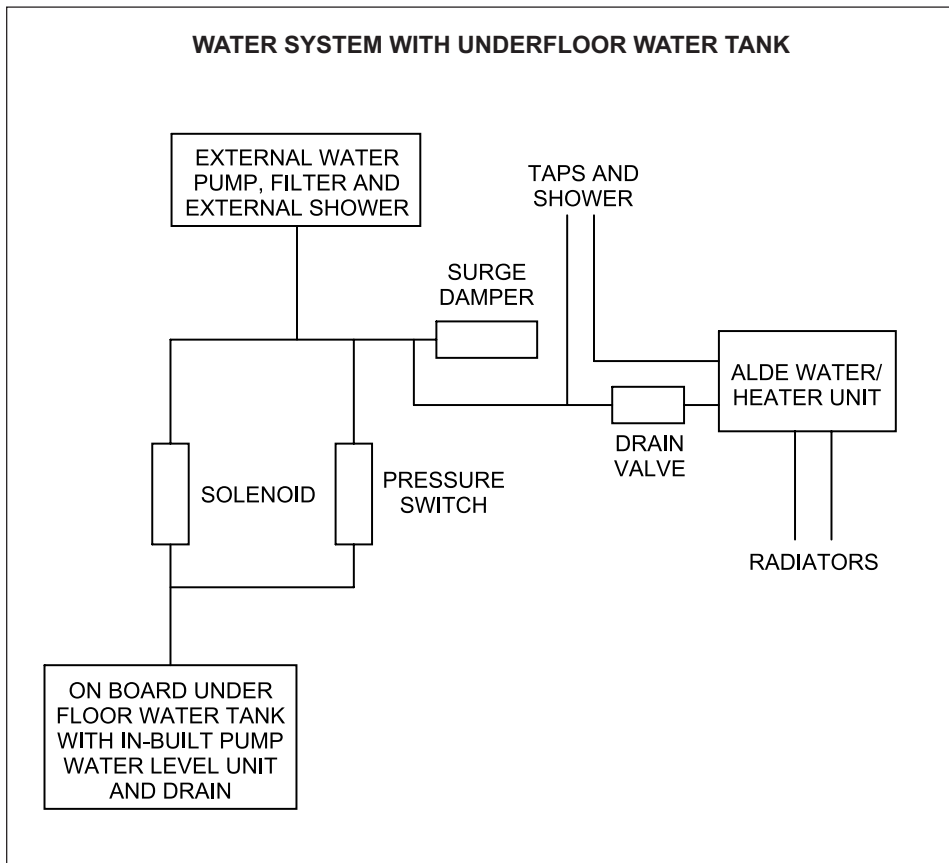



Whale Surge Damper

The surge damper prevents water hammer and also reduces switch hunting on and off.

The surge damper is a completely sealed unit and requires no servicing, however, as with Whale water systems, the complete system should be drained in the winter.

The Filter

The filter attaches directly to the pump and incorporates a non- return valve designed to prevent dirt and grit from entering the pump valves as this will cause pump failure. The filter is fitted during installation to protect the pump.

Pressure Switch

The pressure switch is operated by the opening and closing of the taps/shower. When a tap is opened the pressure in the system is altered which activates the pressure switch supplying power to the selected pump.

Solenoid

The solenoid is an electrically operated valve controlling the water flow from internal and external pumps.

Maintenance

Poor pump performance may be an indication that the filter has become blocked by debris. The filter is easily removed for inspection and cleaning:

- Remove circlip and unscrew filter from pump.
- Pull two halves of filter apart to expose the strainer mesh.
- Remove any debris and replace strainer mesh in position.
- Ensure the rubber seal is correctly seated in the groove on the outlet side of the strainer before pushing the two halves firmly together.
- Attach to the pump and replace the circlip.
- See arrow on pump housing for flow direction.

Care of your Submersible Pump

Care should be taken to ensure that the pump is not allowed to run dry for appreciable periods. Whilst the design will allow some dry running, such as when the tank requires refilling, the pump life will be appreciably lengthened if care is taken to minimise dry running.



SERVICES

Aquaflow Caravan Filler

There is a special filler fitted for use with the Submersible Pump which not only provides a recessed, locking filler cap for water input, but also a polarised power take-off point complete with input plug.

The Water System

A submersible pump is used for pumping water from an external container into the inboard tank of the caravan.

To Operate The System

First ensure that the drain tap on the inboard tank is closed. Place the pump inside your filled container. Place the hose into the filler cap on the side of the caravan. Plug in the 12 volt plug into the socket on the filler cap. When the water container is empty unplug the 12 volt -do not allow the pump to run dry.

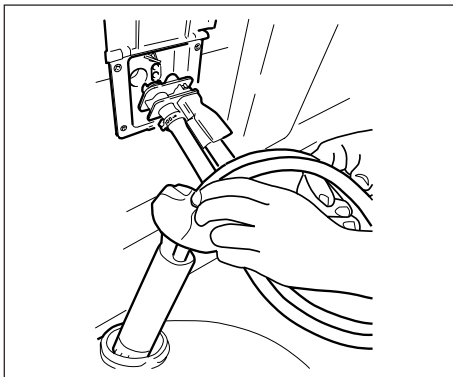

WATER PUMP

The separate plug-in pump assembly consists of a Crystal Maxi pump, hose and plug. The plug provides connection of both water supply to the caravan and 12V dc electric power to the pump. A dust cover is fitted to the connecting dual hose to prevent contaminants falling into the water container.

The Crystal Maxi pump is a completely sealed unit designed for intermittent use. It is NOT self-priming and therefore to ensure proper performance, the pump MUST ALWAYS be fully submersed in water BEFORE plugging into the wall socket.



Initial connection to fresh water supply

1. Fill the fresh water container and place it alongside the wall socket located in the offside external wall of the caravan.
2. Ensure the pump isolator switch at the control panel inside the caravan is switched off.
3. Open the 'hot' kitchen tap. Ensure all other taps are closed.
4. Place the pump into the water container outside the caravan, taking care to ensure the pump reaches the bottom of the container.
5. Lift the lid of the wall socket and fit the pump assembly plug into the socket. Ensure it is pressed in fully.
6. Adjust the dust cover to fit over the opening in the water container to keep contaminants out.
7. Switch on the pump isolator switch at the control panel inside the caravan.
8. Wait until water flows freely from the 'hot' kitchen tap. Allow to flow for a few more seconds to ensure release of any trapped air in the water system, then turn the tap off.

Repeat the same procedure with the 'cold' kitchen tap.

If the system has been drained, the above procedure **MUST** be repeated **EVERY** time the water container is filled.

Switch on the pump isolator at the control panel.

Once it has been properly connected, and a tap is turned on, the pump is activated automatically by a pressure switch.

Fault Finding

1. *Pump runs very noisy but does not pump water.* Likely to occur after water container has been refilled. Pump is air locked. *Cure:* unplug from socket allowing pump to flood, and reconnect by plugging in again. The correct sequence when refilling the container is to unplug, replace pump in container, then reconnect.
2. *Pump fails to deliver water.* The most likely cause will be air in the system. To remedy this, switch off the pump and shake the pump assembly in the water. Then switch on again. Alternatively, make sure the assembly is positioned fully into the housing.
3. *Pump does not run at all.* If not due to blown fuse or faulty connections, then most likely cause is excessive continuous running. *Cure:* replace pump.

Never allow the pump to run dry.

Never allow the pump to run continuously for more than 15 minutes.

Note: When refilling the water container, the pump assembly may be left plugged into the wall socket so that the pump can be kept off the ground by inserting the hose into the groove on the underside of the plug. But, the pump assembly **MUST** be unplugged **BEFORE** replacing the pump into the refilled water container.

STERILISING

When cleaning the water system at the start or the end of the season, it is advisable to use the sterilising fluid, e.g. Milton 2, Chempro SDP or similar. It is recommended that for this operation you use any empty filter body as the fluid reduces the effectiveness of a new filter.

Flush the system thoroughly to remove the effective fluid traces.

After sterilising the system at the start of the season it is recommended that a new filter cartridge is fitted.

NOTES

- Never allow the pump to run dry. Always ensure that the pump is submerged in the water or the life of the pump will be reduced.
- Before winter storage, the water system must be completely drained.
- Clean the water system at the start and end of the season with sterilising fluid (see notes under sterilising).



SERVICES

Water System Winterisation

Caravans may be in use all year round, but when not in use, even for short periods, this procedure should be followed. One night of freezing temperatures is all that is required for expensive permanent damage to water system components.

- a. The whole system must be drained.
- b. Open kitchen taps. Lever taps should be lifted in central position, leave taps open permanently after system drain down.
- c. Open bathroom and shower taps (including shower on/off control rose) and leave open permanently after system drain down.
- d. Shake the shower head to remove the water held there and in the hose. At this point it is recommended to remove the shower head from the hose. Even the smallest amount of frozen water can result in the shower head cracking.
- e. Remove cold water drain plug (if fitted), normally located under the caravan near to the water inlet socket.
- f. If possible remove any remaining water from system plumbing at water inlet sockets and in between in-line pressure switch plumbing.
- g. Disconnect cartridge or in-line filters from plumbing.
- h. Submersible pumps should be shaken out and stored in a dry place.

- i. Drain the external shower bridge connection (including models without external shower) on the Ultraflow housing by inserting the shower connection or open the valve by means of a tool to push on the black rubber pad of the valve.

Cleaning the Water System and Portable Water Tanks

The water systems, and in particular storage tanks, in caravans are susceptible to contamination by bacteria if care is not taken with their use and cleaning. The symptoms caused by bacterial contamination are not purely limited to gastro-intestinal diseases, but may also manifest themselves as ear, nose, throat, eye or skin infections. It is therefore important that you carry out the following procedure prior to using the caravan each time, even if you boil or filter all water you use for drinking.

Water Containers

1. All water remaining in the container should be disposed of so that the container is empty.
2. The outside of the container should be thoroughly cleansed and washed down to remove any dirt, dust or other contaminants. Water at a suitably hot temperature containing an appropriate detergent is recommended for this purpose.

3. Water should be placed in the container, swirled around, then emptied out.
4. The container should then be totally filled with water containing an appropriate disinfectant/sterilant solution and allowed to stand for the recommended contact time (e.g. Milton for 15 minutes).
5. The solution should be emptied from the container.
6. The opening of the container should be cleaned thoroughly with an appropriate pre-prepared wipe impregnated with a disinfectant/sterilant.
7. The container should be inverted whilst stored overnight (if possible).
8. The container must be filled with mains water only and mains water only should be used for the above cleaning procedure.
9. On no account should garden hoses be used to fill water tanks.

Water Systems

1. Drain down the system. (Open all taps to allow air in, enabling the system to drain quickly.)
2. Remove any water filters fitted, and replace with a short length of hose or empty filter cartridge (this will ensure the filter is not affected by the disinfectant/sterilant solution).



3. Fill the system by using the pump with a disinfectant/sterilant solution. (Check that the solution at full strength appears at all taps/showers). Allow to stand for the recommended period of time.
4. Drain the system down using the water systems internal flip switch located under the front off-side bed.
5. Thoroughly clean the outside of all taps/connectors with a cloth soaked in the disinfectant/sterilant.
6. Flush the system through with clean drinking water until no traces of disinfectant/sterilant can be detected at any tap.
7. Replace the filter.

Suitable sterilising chemicals are available from your caravan dealer, accessory shop, chemists or home-brew shops. It is not, however, recommended to use bleach or sodium metabisulphite.

Setting Up the Water System

1. Replace/close all drain valves.
2. Replace shower heads and tap spouts.
3. Close all taps.
4. Refit old filters:
 - a. Check all plumbing connections.
 - b. It is recommended at this point to sterilise your water container and flush the system through with sterilising fluid.

Note: Frost damage cannot be claimed under warranty.



SERVICES

PRESSURE SWITCH

Operation

The pressure switch detects the opening or closing of any tap in the system and switches the pump on or off accordingly. It is located near the water heater.

To prime if fitted with a submersible pump:

1. Trapped air in the submersible pump will not allow the pump to prime. Air can be released by gently shaking the pump under water while the pump is in the water tank but is switched off.
2. If an external submersible pump is used, place the pump in the water before connecting to the side of the van.

At normal flow rates the pump should operate continuously - but at low rates the pressure switch will cycle on and off to maintain back pressure in the pipework.

Adjusting the pressure switch:

If the battery voltage is not constant, cycling may occur. This can be minimised by adjusting the switch's diaphragm sensitivity as follows:

1. With the system properly primed, close all taps and showers.

2. Leave the power supply turned on.
3. Tighten the adjusting screw (clockwise). The pump should now be running.
4. Partly open one cold tap to allow water to flow at about 1 pint per 15 seconds.
5. Now slowly loosen the adjusting screw until the switch starts to click. The switch will then be properly adjusted.

Helpful Hints

- a) If the pump will not run:
 - Pump could be faulty or a wire disconnected.
 - Check that the pump isolating switch is turned on.
- b) If the pump cycles on/off:
 - Battery voltage may be too low (at or below 10.5 Volts). Adjust switch (see text) and/or recharge battery.
 - Check for air or water leaks in taps and piping. Re-adjust pressure switch.
 - Non-return valve may be held open by grit.
- c) If a pump motor runs steadily and will not stop:
 - Battery voltage may be too low (at or below 10.5 volts)

- Check all connections in the pipe-work.
- Remove the adjusting screw, if motor still runs, pump is probably air locked. Turn off the isolator switch and reprime the pump (see text).

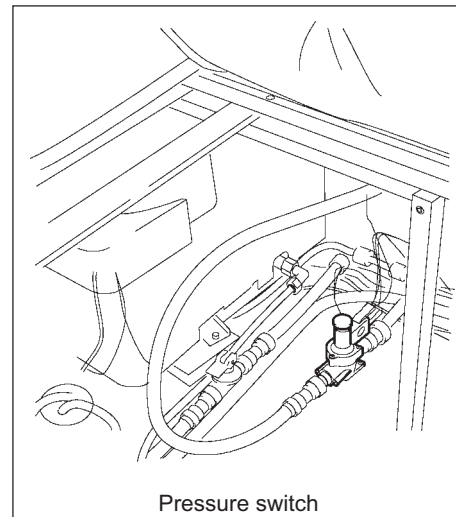

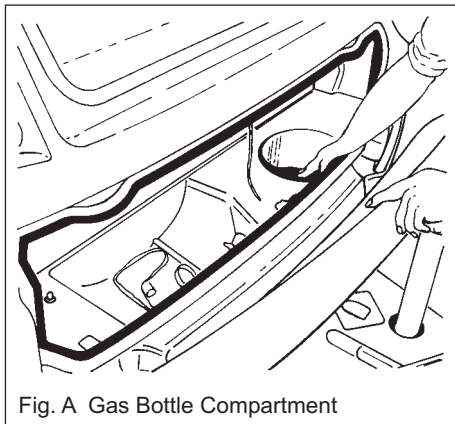

Fig. A Gas Bottle Compartment

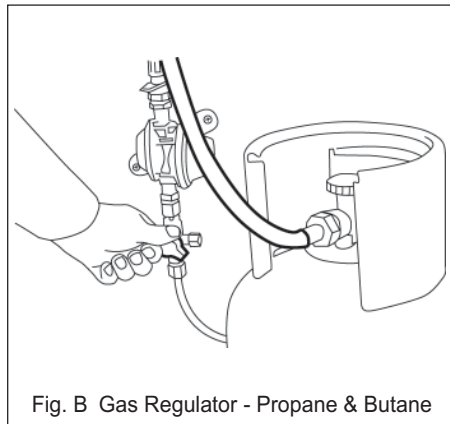

Fig. B Gas Regulator - Propane & Butane

GAS

GENERAL INFORMATION

Gas Bottles

Bottled Liquefied Petroleum Gas (LPG) is the most convenient portable source of fuel for your caravan.

Make sure that heating and cooking appliances and the gas cylinders are switched off before you move the caravan.

Regularly check flexible gas hose, joints and connections for tightness. Finally make sure that each gas appliance is working efficiently to the recommendations of the appliance manufacturers.

In all cases the cylinder contents are in liquid form under pressure from the gas above it, and the pressure is only dependent on the type of L.P.G. and its temperature.

When gas is supplied the pressure in the cylinder is slightly reduced and liquid "boils" off to restore the balance. This action cools the liquid and the cylinder, and condensation or even frost may sometimes be observed on the outside of the cylinder. The cylinder, when in use, is always cooler than the surrounding air so allow plenty of circulation in cool weather and do not cover the cylinder with a "cozy" in the winter.

Butane works satisfactorily at temperatures down to 2° C. Propane should be used for temperatures below this, therefore for all year round caravanners, Propane is of greater use.

There are different sizes of bottles available and it is better to consult your dealer for advice. Gas cannot be supplied from the bottle without an approved regulator.

Hoses connected from regulator to the caravan supply should be made from Neoprene and comply with EN1949. Hoses have a limited life and should be inspected regularly.

The gas cylinders have a recess in the gas bottle compartment into which the cylinders should be restrained by means of the straps provided.

If cylinders are used outwith this compartment you must ensure 1) they are adequately supported b) ventilation is not blocked c) damage will not be caused to fixtures and fittings.

Never use a gas cylinder on its side - always stand cylinders upright - keep them in the gas locker provided (Fig. A).

Please note that the Gas Locker Box is not a watertight compartment.



SERVICES

If you should suspect a gas leak turn off the gas at the bottle and ventilate the caravan by opening the door and windows. Do not operate anything electrical and remove everyone from the caravan until the gas has dispersed. It is part of your annual service to inspect all gas pipes and appliances.

Changing a Gas Cylinder

Before commencing to change a gas cylinder ensure that the valve on the cylinder is turned fully off. Turn off all gas operated appliances.

Remove the gas hose from gas cylinder.

Before refitting a gas cylinder, ensure that all gas operated appliances are turned off – particularly after winterisation. Ensure all connections are secure.

The regulator

Your caravan is fitted with a regulator (capacity 1.5kg/hr) as standard equipment (Fig. B). This is located in front gas bottle locker. The gas regulator has a working pressure of 30mbar and is suitable for both propane and butane liquefied petroleum gas.

Note: Regulator valves should always be in the 'OFF' position when towing.

The 30mbar bulkhead mounted regulator fitted to the caravan requires a 'pigtail' connector for use with UK LPG cylinders, see your dealer for details.

To effect a safe connection with a European cylinder, you will need to obtain a 'pigtail' connector appropriate to the cylinders available in the country you are visiting.

DO NOT use the conventional cylinder-mounted 28mbar/37mbar regulators as the gas pressure is not compatible with the appliances installed in your new caravan/motorhome.

Hoses

Inspect flexible hose(s) regularly for deterioration and renew, as necessary, with approved type. In any case not later than the expiration date marked on the hose. LPG hoses should be routinely replaced at

intervals not exceeding 5 years or as recommended in manufacturers' instructions. Any hoses that show signs of splitting, wear or damage should be replaced irrespective of age.

If the gas supply hose is to be left disconnected for an extended period ensure the open end is protected against the entry of dirt or insects.

Duo Control Regulator

The DuoControl is a safety gas pressure regulation system with automatic changeover for connecting to two gas cylinders for caravans and motorhomes (**Fig C**).

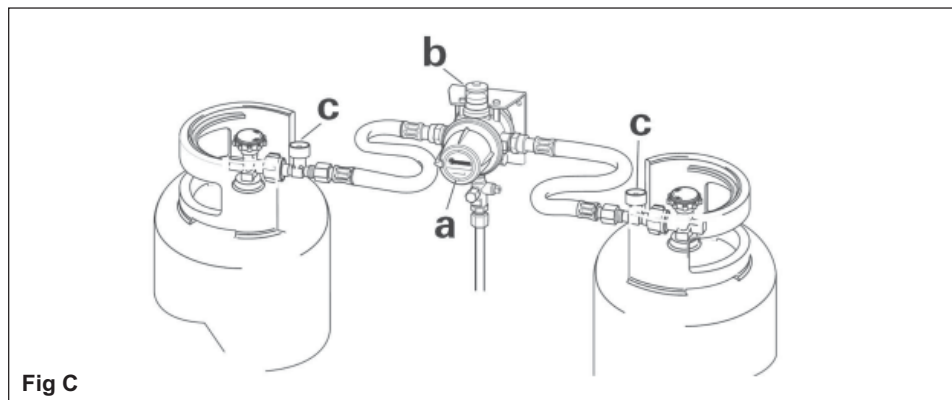

Fig C



Operation

Use the control knob (a) to manually select which cylinder will be operating and which will be held in reserve.

The mica window (b) indicates the status of the operating cylinder:

green = Gas from the operating cylinder.

red = Gas from the reserve cylinder.

- Open gas remote switch if present.
- For example, turn control knob (a) to the left until it stops (left connection is operating cylinder).
- Connect gas cylinders and make sure all hose connections are in good condition.
- Open the valves on both gas cylinders.
- If fitted, press SBS (c) on high pressure hose.
- The display in the mica window will turn green.

Changeover

As soon as the pressure in the operating cylinder falls below 0.6 bar, the DuoControl regulator automatically switches over and begins taking gas from the second gas cylinder. The display in the mica window turns red.

In extreme cold or when a large amount of gas is consumed from the cylinder over a long period of time, the gas pressure may fall below 0.6 bar even though there is still some gas left in the cylinder. This may result in gas being taken from both gas cylinders simultaneously.

If needed, you can change the position of the control knob at any time. Always turn control knob (a) as far to the left or right as it will go (an intermediate position will cause gas to be removed from both gas cylinders simultaneously).

Changing the LPG Cylinder

DuoControl enables replacement of an empty cylinder without interrupting the operation of devices currently consuming the gas. Non-return valves integrated into the inlet connecting piece prevent gas from escaping when only one gas cylinder is attached for a short time.

Please refer to your manual for more information on the DuoControl regulator.

TYPES OF GAS

Butane

Butane is supplied in the U.K. in blue bottles.

Butane is suitable for use at temperatures down to 2°C, but will not work below that temperature.

Propane

Propane is supplied in red bottles which have a left-hand threaded connector.

Propane will work at temperatures as low as -40°C and is therefore suitable for winter caravanning.

Make sure that heating and cooking appliances are turned off, and also the regulator at the gas cylinders before travelling.

Never allow modification of LPG systems and appliances except by qualified persons.



SERVICES

GAS SAFETY ADVICE

Facts about LPG

LPG is not poisonous.

Bi-products are harmless.

There is danger if all air and oxygen were excluded. (Ventilation holes must be kept clear at all times).

LPG has been given a smell by the manufacturers in order to identify leaks.

Awning Spaces LPG Appliance Exhaust

There is no danger of pollution of an enclosed awning space by the LPG exhaust from a refrigerator venting into it.

Space heaters may produce sufficient exhaust to pollute the awning space, if it is totally enclosed, from a general comfort, smell and hygiene point of view. In the extreme case there could be a build up of carbon dioxide to a dangerous level.

Caravan owners are advised to allow some fresh air circulation in the awning space when such appliances are in use.

PRECAUTIONS

- a) Never look for a leak with a match. Always use a soap solution or its equivalent when testing connections. Do not operate any electrical apparatus whatsoever, especially light switches. If the leak is not obvious, the caravan should be evacuated and qualified personnel consulted.
- b) Avoid naked lights when connecting or changing a cylinder.
- c) Check the flexible hose frequently.
- d) The gas is heavier than air and therefore sinks to the lowest point.
- e) Keep bottle gas containers outside (and protected against frost). If they must be kept inside make sure they are well away from heat.

Ventilation

Fresh air circulation should be allowed below the caravan when appliances are in use and when flues terminate below the floor to allow free evacuation of the products of combustion. At least three sides of the underfloor space should always be kept open and unobstructed especially by snow. Do not make any additional openings in the floor.

Fixed ventilation openings are sited under gas appliances in various locations in your tourer.

WARNING

Under no circumstances should fixed ventilation openings or gas appliance flues be obstructed in any manner as this could lead to a build up of dangerous carbon monoxide. Gas drop holes under appliances should also be kept clear at all times. Grilles and flues should be kept clean and free from dust.

All ventilation complies with BS EN1645 and vents should not be obstructed in any manner as this could lead to insufficient fresh air. In this case the confined atmosphere becomes depleted of oxygen which leads to the formation of the highly poisonous gas 'carbon monoxide'. Carbon Monoxide is odourless, colourless and tasteless and will rapidly cause unconsciousness and death with little or no warning prior to collapse. THERE IS NO DANGER WHEN ADEQUATE VENTILATION IS PROVIDED.



Roof-mounted Flue installations

All flue installations should be inspected once a year throughout their length for corrosion. Flues should be replaced if any sign of perforation is found. Ensure that the replacement is of an approved type.

CONNECTION

Ensure that the gas regulator is correctly connected to the gas cylinder in gas bottle compartment and that the hose is tight. Before turning on the gas supply, ensure that all gas operated equipment in the caravan is turned off.

Safety Hints

It is advisable to TURN OFF THE MAIN VALVE on the gas container when the caravan is left unattended for a period or is on tow, except where continuous operation appliances (such as a refrigerator) are in use. AVOID NAKED LIGHTS when connecting or changing a container. Make sure all appliances are turned off.

Space Heating Appliances

Space heating appliances are to be completely extinguished before the caravan is moved and are not to be used when the caravan is in motion. Portable heaters should not be used.

Manifold Locations

Heater and Water Heater manifold located underneath front O/S bed towards bulkhead.

Cooker and Fridge manifold located within compartment below cooker.

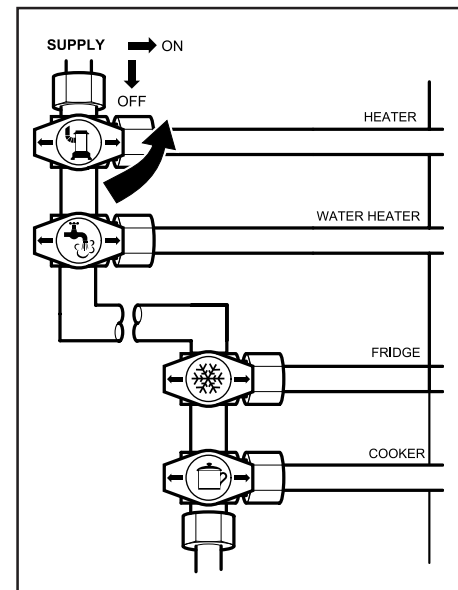



SERVICES

MAINS ELECTRICS

230V Mains Electric Equipment Usage

For your convenience and pleasure this touring caravan is fitted with a 230V mains electrical installation.

Please note: It is possible that all of the 230V mains electrical equipment may not be able to be operated simultaneously. A typical UK caravan park mains hook up point provides a maximum output of 16 amps, although 10 amps is more common and on some continental sites the available output may be as low as 5 amps. If your loading exceeds the site supply it may trip the park's circuit breaker. Please check the available mains output with your site operator.

The following items need to be added together if used simultaneously.

230V mains equipment typical consumption figures:

Fridge	0.5 amps
Charger	1.0 amps
Water heater (max)	5.7 amps
Blown air heaters	4.8 amps
Colour TV	2.5 amps
Microwave	3.5 amps
Air conditioning	4.0 amps
Truma Ultraheat (max)	8.3 amps
Kettle	3.2 amps
Alde central heating	10.0 amps

The mains wiring in Lunar caravans manufactured in the UK complies with the IEE Wiring Regulations, 17th edition, and is safe for the use in the UK. In the UK the on/off switching is always positioned in the live wire. Therefore when the switch is off the current is dead.

Correct polarity of the site supply should always be obtained by the use of a non-reversible plug and socket for connecting the cable to the caravan inlet.

Reverse polarity on overseas use: A plug in polarity tester is used to determine if the polarity is reversed, if so and the site connector is of the two pin type with the two metal strips for the earth, then the plug may be unplugged and inserted the other way round which will then reverse the polarity.

Unfortunately the overseas practice is not always to discriminate between live and neutral wires and the plugs are not necessarily non-reversible. They can be inserted the wrong way round. Consequently when switches are turned off the circuits are not dead. People may touch connections thinking that they are safe and they may still receive a shock.

A residual current device is already fitted to your Alaria Caravan. If a fault occurs and anyone makes indirect contact with a live lead the breaker should trip before a dangerous voltage is apparent.

It is essential that you understand the workings of each electrical circuit. Check supply cable terminals are firm and secure.

Check supply cables for wear and damage. Do not attempt modifications to the caravan electrical installation to accommodate a double supply.

INSTRUCTIONS FOR ELECTRICITY SUPPLY

On Arrival at Caravan Site

1. Before connecting the caravan installation to the mains supply, check that:
 - (a) the main supply is suitable for your installation and appliances, i.e. 230 volts AC, frequency 50 Hertz.
 - (b) your installation will be properly earthed. Never accept a supply from a socket outlet or plug having only two pins, or from a lighting outlet.
 - (c) any residual current device (earth leakage circuit breaker) in the mains supply to the caravan has been tested within the last month. In case of doubt, consult the site owner or his agent.



Note: Always disconnect the electrical connector between the towing vehicle and the caravan before connecting an LV (low voltage) supply to the caravan and before charging the caravan battery by any other means.

2. Ensure that your caravan mains isolating switch (RCD) is in the off position. The MCB's are the breakers for the individual circuits.
3. Remove any cover from the electricity inlet provided on the caravan, and insert the connector of the supply flexible cable.
4. Remove any cover from the socket outlet provided at the site supply point, and connect the plug (at the other end of the supply flexible cable) to this. Switch on the main switch at the site supply point.

IN CASE OF DIFFICULTY CONSULT AN APPROVED ELECTRICAL INSTALLATION CONTRACTOR (WHO MAY BE THE LOCAL ELECTRICITY COMPANY). IT IS DANGEROUS TO ATTEMPT MODIFICATIONS AND ADDITIONS YOURSELF, LAMPHOLDER PLUGS (BAYONET-CAP ADAPTORS) SHOULD NOT IN ANY CIRCUMSTANCES BE USED.

On Leaving the Caravan Site

5. Reverse the procedure described in Paragraphs 3 and 4 above.

IT IS IMPORTANT THAT THE MAIN SWITCH AT THE SITE SUPPLY POINT SHOULD BE SWITCHED OFF, THE SUPPLY FLEXIBLE CABLE DISCONNECTED, AND ANY COVER REPLACED ON THE SOCKET OUTLET AT THE SITE SUPPLY POINT. IT IS DANGEROUS TO LEAVE THE SUPPLY SOCKET OR SUPPLY FLEXIBLE CABLE LIVE.

Periodically

6. Preferably not less than once a year, the caravan electrical installation should be inspected and tested and a report on its condition obtained as prescribed in the Regulations for Electrical Installations published by the Institute of Electrical Engineers.

Never allow modification of electrical systems or appliances except by qualified persons.

Outlet sockets located within the tourer should only be used with a dedicated appliance and not an independent unit.

No appliance shall be used outside when connected to an internal socket.

YOUR CARAVAN IS NOW SUPPLIED WITH 25 METRES OF MAINS CABLE TO COMPLY WITH BS EN1645.

FLEXIBLE WIRING

LIVE	BROWN
NEUTRAL	BLUE
EARTH	GREEN & YELLOW

FIXED WIRING

LIVE	BROWN
NEUTRAL	BLUE
EARTH	GREEN & YELLOW

BBQ Point Information

Models equipped with an external barbecue point can be used to power any gas appliance suitable for the gas used in the caravan, at the working pressure shown on the label in the barbecue outlet box. Please note when using the outlet that the fitted regulator will allow a maximum of 1.5kg per hour of gas to be taken from the gas bottle. Therefore the consumption of gas from both appliances within the caravan and appliance connected to the barbecue point cannot exceed a total of 1.5kg at one time. If you are in any doubt please consult your dealer for advice.





SERVICES

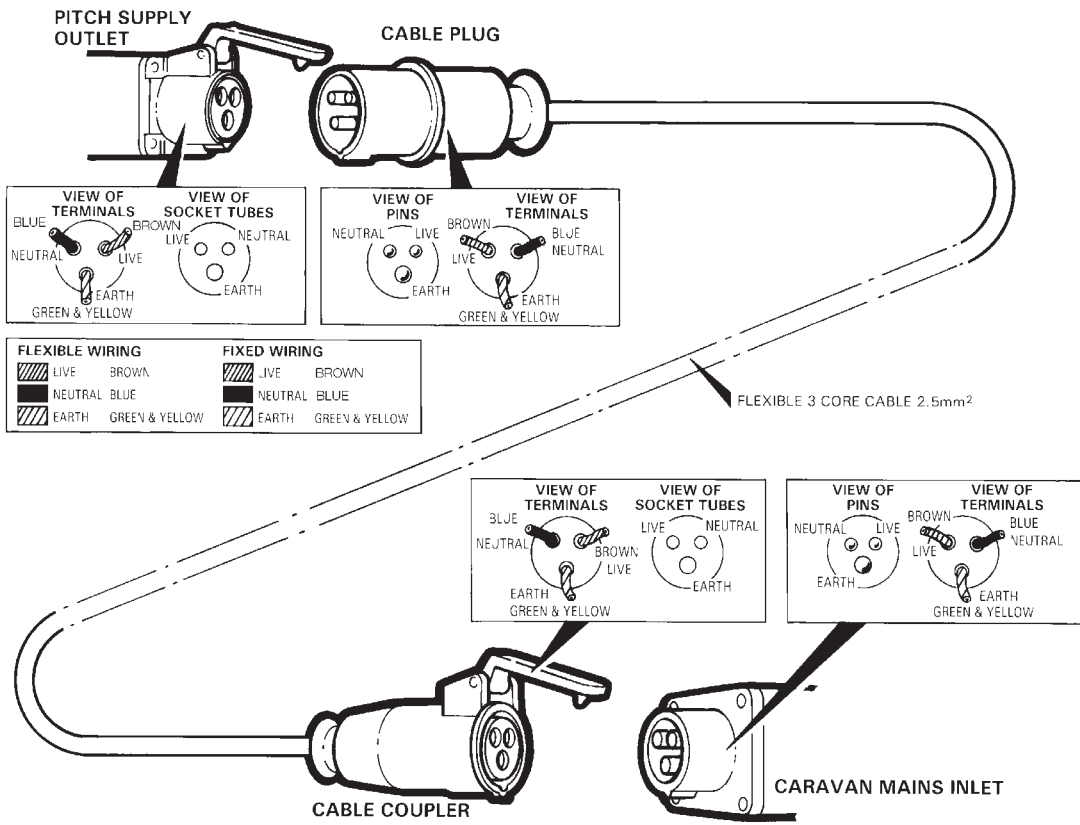

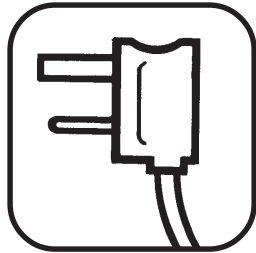

ELECTRICS

Power Control System	68
Battery	74
Fuses	78
Technical Data	85



ELECTRICS

EC500 POWER CONTROL SYSTEM

1 INTRODUCTION

This section of the handbook will guide you through the operation of the electrical system.

Further technical details are contained later in this document or in the supporting technical manual available from www.sargentltd.co.uk

For the safe operation of all electrical equipment within your Leisure Vehicle it is important that you read and fully understand these instructions. If you are unsure of any point please contact your dealer / distributor for advice before use.

The system has a number of key components that you will need to be familiar with before attempting to use the system, these are:

- **The EC500 series Power Supply Unit (PSU)** - a combined mains 230V / 12V consumer unit and controller located in the front bed box.
- **The EC480 series Control Panel (CP)** - a remotely located user control panel used to turn circuits on and off and to display battery and water tank information.

- **The PX-300 Battery Charger / Power Converter** – A separate, air cooled 300 Watt multi-stage power converter unit that charges the batteries and provides 12V DC power.

- **The C44 Road Light Fuse Box** - This small unit is located near the PSU. The unit houses fuses for the road lighting circuits and supplies from the tow vehicle and also has connectors for the optional alarm system and Automatic Trailer Control (ATC) unit.

2 USING THE SYSTEM

The PSU is located in the front offside bed box.

2.1 EC500 Power Supply Unit - Component Layout

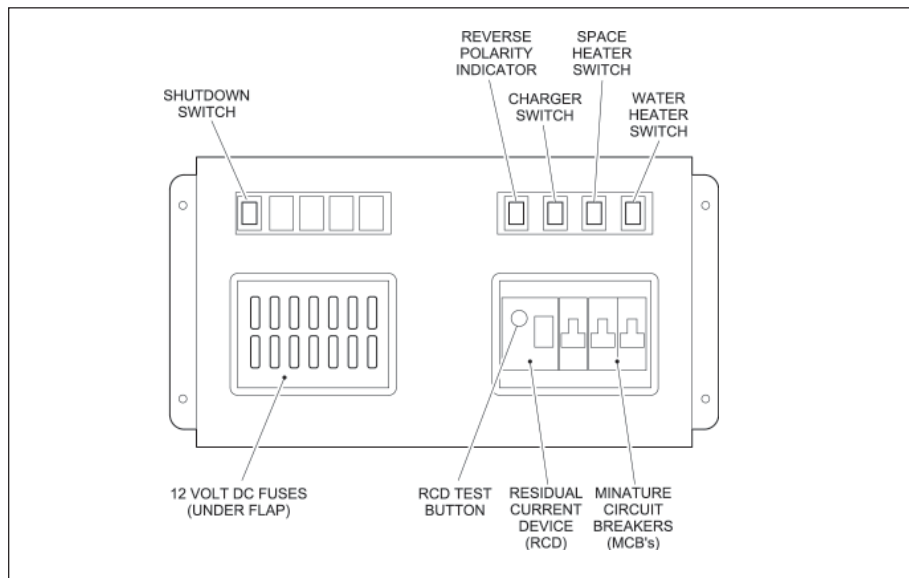



2.2 Activating the System

The EC500 system has a shutdown feature that should be used when the vehicle is in storage or is not being used for long periods of time. This allows the leisure electronics to be turned off when not required to save battery power. When in the off state the alarm and tracking system supplies are still active, most other supplies are turned off.

Before using the system please ensure the system shutdown switch is in the on position (button in).

PSU - 12V Controls

The black system shutdown button is shown on the left. In is on and out is off.

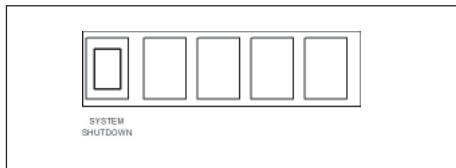

2.3 Connecting to the Mains 230V supply and Safety checks

For your safety it is IMPORTANT that you follow these connections instructions each time your Leisure Vehicle is connected to a mains supply. This section assumes that the system is complete and that a Leisure battery has been installed (see 3.3).

A) Ensure suitability of the Mains Supply. Your Leisure Vehicle should only be connected to an approved supply that meets the requirements of BS7671 or relevant harmonised standards. In most cases the site warden will hold information regarding suitability of supply. If using a generator you also need to comply with the requirements / instructions supplied with the generator. Please note that some electronic generators may not be compatible with your leisure system. Further generator operational information is contained elsewhere in this manual.

B) Switch the PSU internal Power Converter OFF. Locate the green 'Charger' power switch on the PSU and ensure the switch is in the off position (button out) before connection to the mains supply.

C) Connect the Hook-up Lead. Firstly connect the supplied hook-up lead (orange cable with blue connectors) to the Leisure Vehicle and then connect to the mains supply.

D) Check Residual Current Device operation. Locate the RCD within the PSU and ensure the RCD is switched on (lever in up position). Press the 'Test' button and confirm that the RCD turns off (lever in down position). Switch the RCD back to the on position (lever in up position). If the test button failed to operate the RCD see section 3.14.

E) Check Miniature Circuit Breakers. Locate the MCB's within the PSU (adjacent to the RCD) and ensure they are all in the on (up) position. If any MCB's fail to 'latch' in the on position see section 3.14.

F) Turn the PSU ON. Locate the black 'Shutdown' button and ensure it is in the on position (press button to change, button in = on, button out = off). Locate the green 'Charger' switch on the PSU and turn to the on position (press button to change, button in = on, button out = off). The charger switch will illuminate when turned on.

G) Check correct Polarity. Locate the 'Reverse polarity' indicator on the PSU and ensure that the indicator is NOT illuminated. If the indicator is illuminated see section 3.14. Please note that this indicator works in conjunction with the charger switch, so will only operate when the charger is on.

H) Check operation of equipment. It is now safe to operate the 12v and 230v equipment.



ELECTRICS

PSU - 230V Controls

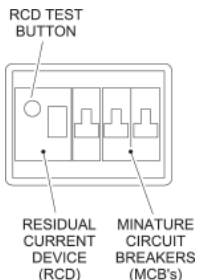

Lever type switch, far left - Residual Current Device (RCD) and main 230V on/off switch.

Push button, far left - RCD test button.

3 x lever switches, right - Miniature Circuit Breakers (MCB). Note the lever colour and MCB rating may vary. See the safety and rating sticker adjacent to the PSU for further details.

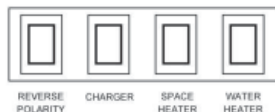

Red indicator, far left - Reverse polarity warning indicator. This illuminates when the green charger is turned on (see below) and the 230V supply polarity is reversed (see 3.10).

Green push switch - Charger switch, this switch turns the 12V battery charger on or off. In is on out is off.

Amber push switch - Space heater switch, this switch turns the 230V supply to the space heater / combination heater / central heating system on or off. In is on out is off.

Clear push switch - Water heater switch, this switch turns the 230V supply to the separate water heater on or off. In is on out is off.



2.4 Control Panel - Component Layout



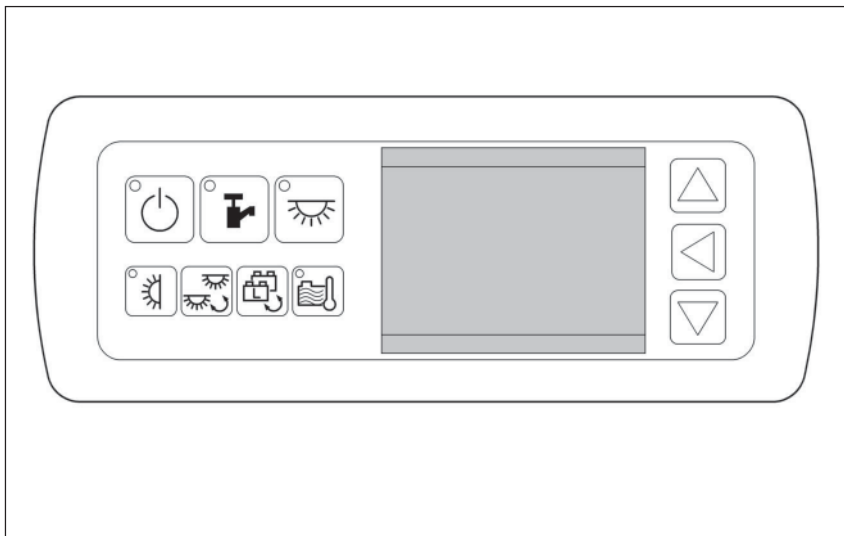





EC480 Digital Control Panel (LCD graphic display)





ELECTRICS

2.5 Control Panel Operation

Button	Button Description
	Power Button. Press the power button to turn the leisure power on. Press the button again to turn the power off. The adjacent LED will illuminate when the power is on, and also the voltage of the selected battery will be displayed on the screen. When the car engine is running this LED will flash to indicate the leisure battery is being charged.
	Pump Button. With the power on, press the pump button to turn the water pump on. Press the button again to turn the pump off. The adjacent LED will illuminate when the pump is on, and also the level of the water tank will be displayed on the screen (if the optional onboard water tank is fitted). This LED may also flash during tank filling operations, see 3.6 for further details.
	Light Button. With the power on, press the light button to turn the main internal lighting on. Press the button again to turn the lights off. The adjacent LED will illuminate when the lights are on. The lights will be turned on and off automatically each time the power button is operated.
	Awning Light Button. With the power on, press the awning light button to turn the awning light on or off. The adjacent LED will illuminate when the light is on.
	Levels / scroll button. Use this button to scroll through the various levels screens / menu items or to cancel alarms / warnings. Note: The screen illumination / backlight will turn off after a period of time. Press the levels button or wave your hand in front of the illumination sensor to reactivate the illumination.
	Select button. Use this button to select options/items or to change settings.
	Illumination sensor. With the power turned on, the illumination sensor detects the presence of your hand when it gets within 100mm of the sensor. The sensor is located at the top left of the control panel. Simply wave your hand in front of the sensor to activate the screen illumination.
	Tank fill. With the power on, press the tank fill button to fill the internal tank from the aqua roll. When the internal tank is full, tank fill automatically turns off then the pump button will need to be selected to draw water from the taps..



2.6 Operation while driving

The EC500 system is designed to shutdown parts of the system whilst the engine is running. This is to meet Electro Magnetic Compatibility (EMC) regulations and to ensure the safe operation of the system.

Please ensure the system shutdown switch on the PSU is in the “on” (button in) position before driving (see 2.2). This will ensure the electronic system is active and will therefore be able to control the charging process, supply the refrigerator and monitor other system circuits.

If you hear a warning buzzer when the engine is started, please see the control panel display for details and also refer to section 3.8.

3 System Technical Information

The following section provides further technical information relating to the electrical system.

3.1 Residual Current Device & Miniature Circuit Breakers

The Residual Current Device (RCD) is basically provided to protect the user from lethal electric shock. The RCD will turn off (trip) if the current flowing in the live conductor does not fully return down the neutral conductor, i.e. some current is passing through a person down to earth or through a faulty appliance.

To ensure the RCD is working correctly, the test button should be operated each time the vehicle is connected to the mains supply (see section 2.3)

The Miniature Circuit Breakers (MCB's) operate in a similar way to traditional fuses and are provided to protect the wiring installation from overload or short circuit. If an overload occurs the MCB will switch off the supply. If this occurs you should investigate the cause of the fault before switching the MCB back on.

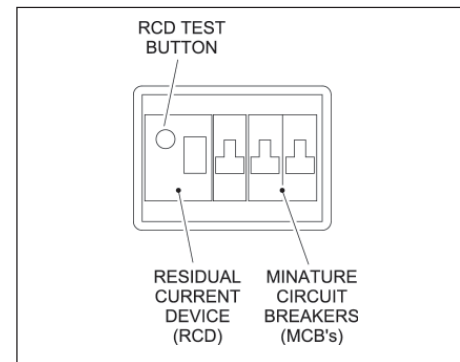

The following table shows the rating and circuit allocation for the three MCB's

MCB	Rating	Description (cable colour)
1	10 Amps	230v Sockets (white)
2	16 Amps	Combination water heater / central heating system (yellow) Extra 230V sockets (white)
3	10 Amps	Fridge (black) 12V Charger (internally socketed)



ELECTRICS

3.2 Battery Charger

The EC500 system incorporates an intelligent three-stage battery charger / power converter.

During stage 1 the battery voltage is increased gradually while the current is limited to start the charging process and protect the battery. At stage 2 the voltage rises to 14.4V to deliver the bulk charge to the battery. When the battery is charged, the voltage is decreased at stage 3 to 13.6V to deliver a float charge to maintain the battery in the fully charged state. The charger can be left switched on continuously as required but if you are using your caravan as a permanent home please contact Sargent for advice.

The battery charger / power converter also provides power to the leisure equipment when the mains supply is connected. This module supplies DC to the leisure equipment up to a maximum of 25 Amps (300 Watts), therefore the available power is distributed between the leisure load and the battery, with the leisure load taking priority as per the following example

Leisure load	Available power for battery charging
5A	20A
10A	15A
15A	10A
20A	5A

WARNING: Under heavy loads the charger case may become hot. ALWAYS ensure any ventilation slots have a clear flow of air. Do not place combustible materials against/ adjacent to the charger.

3.3 Leisure Battery

3.3.1 Type / Selection

For optimum performance and safety it is essential that only a proprietary brand LEISURE battery is used with a typical capacity of 75 to 120 Ah (Ampere / hours). A normal vehicle battery is NOT suitable. This battery should always be connected when the system is in use.

The PSU is configured to work with standard lead acid leisure batteries, and in most cases is also compatible with the latest range of Absorbed Glass Matt (AGM) batteries. Before fitting non-standard batteries please check that the charging profile described in 3.2 is suitable for the type of battery by referring to the battery documentation or battery manufacturer.

The battery feed is fitted with an inline fuse between the battery and the electrical harness, and is usually located immediately outside the battery compartment or within 500mm of the battery. The maximum rating of this fuse is 20A.

3.3.2 Installation & Removal

Always disconnect the 230v mains supply and turn the PSU green charger switch to the off position (button out) before removing or installing the battery.

When connecting the battery, ensure that the correct polarity is observed (black is negative [-] and red is positive [+]) and that the terminals are securely fastened. Crocodile clips must not be used.

WARNING: Explosive gases may be present at the battery. Take care to prevent flames and sparks in the vicinity of the battery and do not smoke.

3.3.3 Operation / Servicing

Under normal circumstances it should not be necessary to remove the battery other than for routine inspection of the terminals and “topping up” of the battery fluid where applicable. Please see instructions supplied with the battery.

Note: Do not over discharge the battery. One of the most common causes of battery failure is when the battery is discharged below the recommended level of approximately 10v. Discharging a battery below this figure can cause permanent damage to one or more of the cells within the battery.



To prevent over discharge, the EC500 system incorporates a battery protect circuit that warns the users and then disconnects the batteries when they fall below set values.

3.4 Generator Usage

Caution should be used before connecting a generator to your caravan or motorhome.

WARNING: Never start or stop the generator while electrical loads are connected and switched on. Start the engine, let it stabilise and then connect the electrical load. To stop the engine, disconnect the electrical load and let engine stabilise before switching off.

Whilst some generators use electronic inverter technology, others use a more basic principle to generate the 230V supply. Preference should be to choose a generator which produces a consistent sinusoidal wave form with accurate voltage control.

The Reverse Polarity warning light on the PSU may illuminate when using a Generator. This is a normal side effect when using some types of generator. Instead of connecting the neutral conductor to earth, some generators centre tap the earth connection making both neutral and live conductors 110V above earth. This 110V difference causes the neon polarity indicator to illuminate.

In most cases it is safe to use a generator, but please consult the generator handbook for further information.

3.5 Solar Charge Management

The EC500 PSU incorporates a built-in solar charge monitor which will measure and display the current being generated by an attached solar panel (when fitted). For this display to work correctly the solar panel must be connected via a suitable solar regulator to the provided solar panel connection and not connected direct to the battery.

3.6 Water System Operation - Optional Tank Fill Feature

With the optional onboard water tank installed the system may also include an automatic tank fill/infill feature which operates as follows:

3.6.1 One Shot Fill/Auto Change

With the water pump turned off and an empty on-board tank and a full external tank (Aqua Roll) the user will press tank fill button on the control panel and turn tank fill on. The external pump will turn on and fill the on-board tank from the external tank (pump LED on control panel flashes to indicate filling). When the on-board tank is full the external pump will stop and tank fill will automatically be turned off at the control panel. If the external tank runs dry before the on-board tank is full the system will turn the external pump off after 5 minutes to protect the pump from burn out.

The user would now go and refill the external tank.

The user can now turn the main pump on (tap button) and the internal pump will deliver water to the taps. Once the on-board tank is empty the relay will switch over to the external tank and water will continue to be delivered until the external tank is empty. The external pump will not stop when the external tank is empty; the user will need to turn the pump off when water stops flowing.

If the user does not want to use the on-board tank, instead of initially using the tank fill option they can just turn the main pump on (tap button) and the external pump will deliver water to the taps.

Note: The tank fill option should not be turned on when the main pump is turned on.



ELECTRICS

3.7 Awning Light Operation

The awning light is controlled by the control panel awning light button. The awning light is also linked to the optional alarm system to enable remote control with the alarm fob.

3.8 System Warnings

The system incorporates a number of warnings that are active at specific times. These are summarised below and also covered by relevant sections of this manual.

Warning	When	Type
Fresh water level low	With pump turned on and fresh water level low (less than 25% full)	Message on screen and 30 second audible beep.
Leisure battery voltage low	With control panel power on and leisure battery selected (as active battery) and the voltage level falls below 10V.	Message on screen and 30 second audible beep.
	With control panel power on and leisure battery selected (as active battery) and the voltage level falls below 9V.	Message on screen and 30 second audible beep. If no action taken after 30 seconds then the system will switch the power off to prevent severe discharge of the battery.
	<p>Note: This is an emergency cut off level to protect the battery from severe damage. You should not rely on this cut off level during normal operation, but manage your power consumption to a discharge level of 11.5V or above.</p> <p>This cut off only applies to power drawn from the battery by the leisure equipment that is controlled by the control panel power switch; it will not protect the battery from discharge by permanently connected equipment.</p>	



Warning	When	Type
Leisure battery voltage high	With control panel power on or off and leisure battery is selected (as active battery) and the voltage level rises above 15V	Message on screen and repeated beeps from the control panel. The beeping will not stop until the fault is cleared.
Vehicle battery warnings	If the vehicle battery is selected instead of the leisure battery, then the same warnings described above for the leisure battery are applied to the vehicle battery.	
Engine running	When the engine is started the system power will be turned off	Message on screen, Leisure & Vehicle battery symbols indicating both batteries are connected for charging. The leisure battery voltage is also shown on screen.
Mains lead (hook-up cable) still connected/plugged in	When the engine is started the system and the mains cable is still plugged in and the charger is switched on.	Message on screen and repeated beeps from the control panel. The beeping will not stop until the hook-up lead is removed.



ELECTRICS

3.9 12 Volt DC Fuses

WARNING: When replacing fuses always replace a fuse with the correct value. NEVER replace with a higher value/rating as this could damage the wiring harness. If a replacement fuse 'blows' do not keep replacing the fuse as you could damage the wiring harness. Please investigate the fault and contact your dealer.

The table opposite shows the fuse allocation for the 15 fuses fitted to the PSU. Please note that fuses are dependant on PSU versions, so not all fuses may be present or used.

Fuse	Rating	Fuse Colour	Description
1	10 Amps	Red	Toilet
2	5 Amps	Tan	Ignitions
3	10 Amps	Red	Motorhomes Only - Electric Step
4	10 Amps	Red	Water Pumps
5	10 Amps	Red	Permanent Supplies
6	20 Amps	Yellow	Leisure Battery
7	20 Amps	Yellow	Vehicle Battery
8	10 Amps	Red	Fans / Heater
9	10 Amps	Red	Power Circuits
10	10 Amps	Red	Lighting Circuit 1
11	10 Amps	Red	Lighting Circuit 2
12	10 Amps	Red	Motorhome only - En-route Circuits
13	10 Amps	Red	Motorhome only - Tank Heaters
14	10 Amps	Red	Tank fill Solenoid
15	25 Amps	White	Charger (note this fuse is fitted inside the PSU)

The following table shows details of the fuse(s) located at the Leisure battery.

Fuse	Rating	Fuse Colour	Description
Battery 1	20 Amps	Yellow	Fuse remotely located near battery



The following table shows details of the fuse(s) located at the Road Light fuse box

Fuse	Rating	Fuse Colour	Description
1	20 Amps	Yellow	Fridge Supply 12V
2	5 Amps	Tan	Left Hand Tail Lights
3	5 Amps	Tan	Right Hand Indicators
4	5 Amps	Tan	Fog Lights
5			Spare location
6	20 Amps	Yellow	Car Battery Supply 12V
7	5 Amps	Tan	Right Hand Tail Lights
8	5 Amps	Tan	Left Hand Indicators
9	7.5 Amps	Brown	Stop Lights
10	5 Amps	Tan	Reverse Lights

3.10 Common Fault Table

Fault	Possible Cause	Proposed Fix
No 230 volt output from PSU	Connecting lead between the site and Leisure Vehicle not connected	Check and connect lead as per 2.3C
	RCD switched off	Reset RCD as per 2.3D
	RCD not operating correctly	Check supply polarity; if the RCD continues to fail contact your Dealer as there is probably an equipment or wiring fault
	MCB switched off	Reset MCB by switching OFF (down position) then back ON (up position), if the MCB continues to fail contact your Dealer as there is probably an equipment or wiring fault
	No or deficient supply from site	Contact site Warden for assistance
	Other fault	Contact your Dealer.



ELECTRICS

3.10 Common Fault Table (continued)

Fault	Possible Cause	Proposed Fix
Reverse Polarity light is illuminated on PSU	Mains Supply reversed?	The reverse polarity light is designed to illuminate when the Live and Neutral supply has been reversed/crossed over. If the light illuminates there is a problem with the site supply or the cable connecting the supply to your vehicle. The light is designed to work on UK electrical supplies (where the neutral conductor is connected to earth at the sub station). If you are using your vehicle outside the UK this light may illuminate when no fault exists. In these cases consult the site warden for advice.
	Generator being used	'The Reverse Polarity warning light is on when using my Generator'. This is a normal side effect when using some types of generator. Instead of connecting the neutral conductor to earth, some generators centre tap the earth connection making both neutral and live conductors 110V above earth. This 110V difference causes the neon polarity indicator to illuminate. In most cases it is still safe to use the generator, but please consult the generator handbook for further information.
Control Panel problems	Control panel has no display	Backlight/illumination may have switched off. Press the select button to reactivate the backlight. Check batteries and fuses, turn PSU shutdown switch and charger switch on and ensure mains supply is connected. Check control panel connecting lead at PSU and behind Control Panel. Contact your Dealer
	12v Power turns off	Battery protect feature has operated to protect the Vehicle battery and or the Leisure battery. See 3.8 Engine has been started, all equipment has been disconnected to meet EMC requirements. See 2.7
	Control panel locked/ erratic function	Observe control panel handling instructions. Control panel software may have crashed. Reboot control panel by turning off the PSU isolate switch. Wait 30 seconds then turn the switch back on.
No 12 volt output from PSU	No 230V supply	Check all above.
	Charger not switched on	Turn charger switch on, switch will illuminate
	Battery not connected and / or charged	Install charged battery as per ??
	Power button on control panel not switched on	Turn power on at control panel
	Battery flat / Battery fuse blown	Recharge battery, check fuses, check charging voltage is present at battery.
	Fuse blown	Check all fuses are intact and the correct value fuse is installed as per fuse table
	Equipment switched off / unplugged	Check equipment is switched on and connected to the 12V supply.



3.10 Common Fault Table (continued)

Fault	Possible Cause	Proposed Fix
	PSU overheated / auto shutdown operated	Reduce load on system. Allow PSU to cool down. PSU will automatically restart when cool.
	Other fault	Contact your Dealer.
Pump not working	Fuse blown	Replace fuse with correct value as per fuse table.
	Pump turned off	Turn pump on by pressing the pump button at the control panel.
	Setting incorrect	Both the internal and external pump feeds are controlled from the control panel. To alter the setting of the pump switch see your dealer. Ensure the setting matches your desired requirement.

3.11 Contact details

Sargent Electrical Services Limited, provide a technical help line during office hours. Please contact 01482 678981 if you require technical help. For out of hour support please refer to the tech support section of the Sargent web site www.sargentltd.co.uk.

4 EC480 Control Panel

In addition to the information contained in section 2.5 (Control Panel Operation), the following section provides further detail information.

4.1 Backlight Operation

The screen backlight (illumination) is turned on and off automatically. When operating on battery power only the backlight time is 30 seconds. When operating on mains power the backlight time is increased to 2 minutes. Pressing the select button will reactivate the backlight.

If the large clock screen is selected (see 4.4.4 below) and the mains supply is on then the backlight will remain on continuously.

4.2 Header Area



The header area of the screen shows the following information;
At the left, the external temperature in centigrade
At the right, the internal temperature in centigrade
In the centre, the current time (24 hour clock)
In addition to the above, the following symbols (when shown) indicate;



Mains supply connected and charger switched on



Alarm clock set



Event timer set

4.3 Footer Area

System TIME settings (Press < to edit)

The footer area of the screen shows details of the current information screen, and may also show additional information during specific operations.

4.4 Information Area

The main information area can display a variety of system information screens. These have been designed to present the information in a clear and concise form, while retaining technical detail for the more advanced users.

The selected screen can be changed by using the down or up buttons, and work on a continuous loop basis. The selected screen may be changed automatically by the system depending on the action being performed.



ELECTRICS

4.4.1 Splash Screen

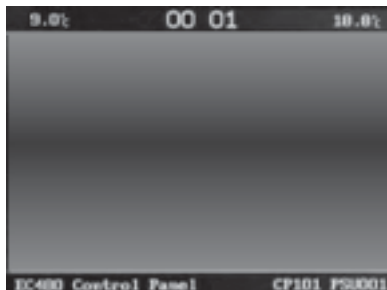

This screen shows the header and footer detail, along with the logo.

4.4.2 System Levels Screen

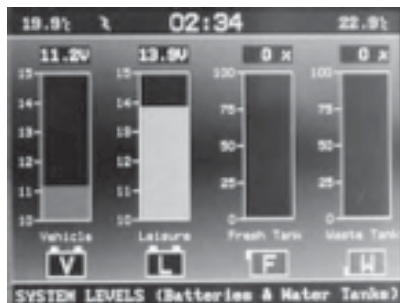

This screen shows, from left to right;

- [V] Vehicle battery voltage gauge. This gauge shows the voltage of the Vehicle battery in bar format, with the precise reading shown at the top of the bar. The actual bar changes colour according to the battery voltage. Less than 10.9V = red (Poor), 10.9V to 11.8V = yellow (Fair), 11.9V to 14.4V = green (Good).
- [L] Leisure battery voltage gauge. This gauge shows the voltage of the Leisure battery in bar format, with the precise reading shown at the top of the bar. The actual bar changes colour according to the battery voltage. Less than 10.9V = red (Poor), 10.9V to 11.8V = yellow (Fair), 11.9V to 14.4V = green (Good).
- [F] Fresh water level gauge. This gauge shows the level of water in the Fresh water tank, with the reading also shown at the top of the bar. The actual bar changes colour according to the water level. 25% = red, 50% = yellow, 75% and above = green.
- [W] Waste water level gauge. This gauge shows the level of water in the Waste water tank, with the reading also shown at the top of the bar. The actual bar changes colour according to the water level. 25% = green, 50% = yellow, 75% and above = red.

4.4.3 Active Battery Screen

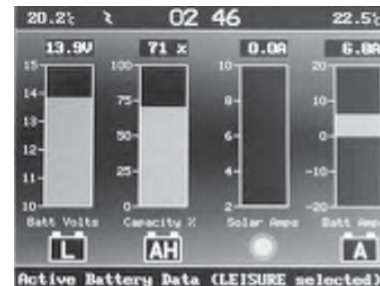

This screen is automatically selected when the battery select button is operated. The battery symbol bottom left will contain a 'L' if the leisure battery is selected and a 'V' if the vehicle battery is selected. From left to right;

- [L or V] Active battery voltage gauge. This gauge shows the voltage of the Active battery (the currently selected battery) in bar format, with the precise reading shown at the top of the bar. The actual bar changes colour according to the battery voltage. Less than 10.9V = red (Poor), 10.9V to 11.8V = yellow (Fair), 11.9V to 14.4V = green (Good).
- [AH] Leisure battery calculated capacity (percentage of Amp Hours). When the leisure battery is active (selected), this gauge will be shown. The gauge shows



the predicted charge capacity of the battery. As the battery is charged this gauge will increase, as the battery is discharged (used) this gauge will reduce. This can provide a useful indication of usable battery power.

- [SUN] Solar panel ammeter. This gauge shows the current in Amps that is being provided by the solar panel (when fitted). The system will decide which battery to direct the solar power to. This is based on system logic (see section 3.6) and is indicated by a 'L' or 'V' in the centre of the sun logo.
- [A] Battery ammeter. This gauge shows the current in Amps going into or out of the Active (selected) battery. Positive current (+) indicates charging of the battery, and is indicated by a green bar. Negative current (-) indicated discharging of the battery, and is indicated by a yellow bar (low discharge) or red bar (high discharge).

4.4.4 Large Clock Screen



This screen shows a large display clock in 24 hour format.

4.4.5 Time and Timer Event Settings Screen

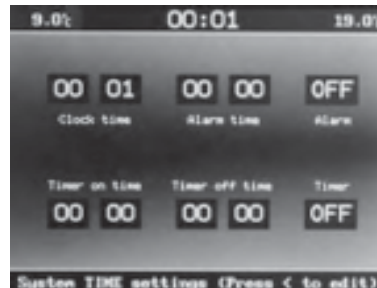

This screen is used to adjust any of the system times and to set the alarm clock or event timer.

Press the select button to move through each setting. Press the up / down buttons to adjust the setting.

- Set Clock Time. First adjust the hour using the up / down buttons, then press select again to move to minutes and adjust with the up / down buttons.
- Set Alarm Time. Press the select button to move to alarm hour setting. Press the up / down buttons to adjust the setting, then press select again to move to minutes and adjust with the up / down buttons. Press select again to move to alarm on / off. Press the up / down buttons to adjust the setting. If the alarm is turned on, a bell symbol will be shown in the header area.
- Set Timer event on Time. Press the select button to move to timer hour setting. Press the up / down buttons to adjust the setting, then press select again to move to minutes and adjust with the up / down buttons.
- Set Timer event off Time. Press the select button to move to timer hour setting. Press the up / down buttons to adjust the setting, then press select again to move to minutes and adjust with the up / down buttons. Press select again to move to timer on / off. Press the up / down buttons to adjust the setting. If the timer is turned on, a stopwatch symbol will be shown in the header area.
- Press select again to exit the settings



ELECTRICS

4.4.6 System Warnings Screens



The system can display a number of warnings. The control panel will beep and display the appropriate message. Press the select button to cancel the warning.



5 TECHNICAL DATA & APPROVALS

5.1 Outline specification - EC500PSU & EC370 Control Panel

INPUT 230V	230 Volts / 0 to 16 Amps	+ / - 10%
OUTPUT 230V	RCD protected, 3 x MCB outputs of 1 x 16A and 2 x 10A Separate switched channels for water heater, space heater and charger	
INPUT 12V	2 x 20A battery inputs via 2 x 4 way connectors	
SOLAR INPUT	1 x Dedicated solar panel input (20 to 100W panel) via a 2 way connector	
OUTPUT 12V	25A total output via multiple switched channels protected by 14 fused outputs	
CHARGER	Input 220-240 Volts AC +/- 10%, Frequency 50 Hz +/- 6%, Current 3A max. DC Output 13.6 to 14.4 Volts nominal, Current 25 Amps max (300 Watts) Overall size (HxWxD) 50 x 250 x 135mm	Fixing centres 128*128mm 1.2 kg
Signal INPUT	4 x Fresh water level, 1 x Engine running, plus multiple vehicle connections	Fresh water negative sensed
Data IN / OUT	CANBUS Data communication and power to Control Panel via 6 way connector	
IP rating	IP31	
Operating temperature	Ambient 0 to 35° Centigrade PSU case temperature with full load 65°C Max	Automatic shutdown and restart if overheated/overloaded
EC500 PSU	Overall size (HxWxD) 315 x 195 x 150mm Clearances 75mm above, 50mm left and right	Weight 2.9kg
EC370 Control Panel	Overall size (HxWxD) 80 x 194 x 25mm Cut-out size (HxW) 60 x 165mm	Fixing centres 190mm Weight 180g



FITTED EQUIPMENT

Refrigerators	88
Dometic RMD 8555 Fridge Freezer	88
Oven, Hob & Grill	97
Microwave	101
Alde Heating	102
Thetford C-260 Toilet	107
Awning Points	111
Rooflight	111
TV Antenna	112
CD/Radio/MP3	115
Alarm	116
Flyscreens/Blinds	117
Window Care	119
Condensation	119
ABS Panels	121
Badges	121
Bunk Beds/Front Beds	122
How to Maintain Furniture in a Caravan	124



REFRIGERATOR

Fridge Freezer RMD 8555

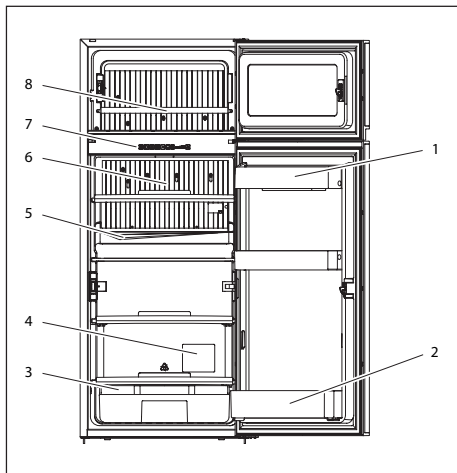

The refrigerator is an absorption refrigerator. The refrigerator is designed to operate with different types of power and can be run on an AC power supply, a DC power supply or with liquefied gas (propane or butane). The vehicle battery can be used for DC operation. The thermostatic control ensures that the refrigerator temperature is kept constant and as little power as possible is consumed.

The refrigerator is equipped with an automatic flame monitor which automatically

interrupts the gas supply after approx. 30 seconds if the flame goes out.

The RMD8xx5 refrigerators have an automatic operating mode which selects the most economical power mode connected.

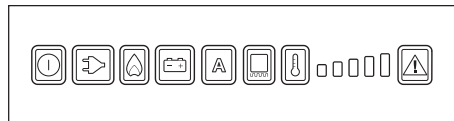

Safe Operation

- Close the refrigerator door before beginning a journey.
- The refrigerator unit at the back of the refrigerator becomes very hot during operation. Protect yourself from coming into contact with hot parts when removing ventilation grilles.
- Only store heavy objects such as bottles or cans in the refrigerator door, in the vegetable drawer or on the bottom shelf.

Note: Do not use electrical devices inside the refrigerator unless they are recommended by the manufacturer for that purpose.

Danger of overheating!

Always ensure sufficient ventilation so that the heat generated during operation can dissipate. Make sure that the refrigerator is sufficiently far away from walls and other objects so that the air can circulate.

- Make sure that the ventilation openings are not covered.
- Do not fill the inner container with ice or fluid.
- Protect the refrigerator and the cable against heat and moisture.
- Make sure that foodstuffs do not touch the walls of the cooling area.

Safety when operating with DC power

Only select operation with DC power supply (battery mode) if the vehicle A engine is running and providing sufficient voltage to the light system, or if you are using a battery monitor.

Safety when operating with AC power

- Check that the voltage specification on the type plate is the same as that of the power supply.
- Only use the cable supplied to connect the refrigerator to the AC mains.
- Never pull the plug out of the socket by the connection cable.



Safety when operating with gas

WARNING!

- **Only operate the refrigerator** at the pressure shown on the type plate. Only use pressure controllers with a fixed setting which comply with the national regulations (in Europe EN 12864).
- **Never** store liquid gas cylinders in unventilated areas or below ground level (funnel shaped holes in the ground).
- Keep liquid gas cylinders away from direct sunlight. The temperature may not exceed 50 °C.
- Never operate the refrigerator with gas
 - at petrol stations
 - while driving
 - while transporting the caravan or mobile home with a transport vehicle or tow truck
- Never use a naked flame to check the refrigerator for leaks.
- If you smell gas:
 - Close the gas supply cock and the valve on the cylinder.
 - Open all windows and leave the room.
 - Do not press an electric switch.
 - Put out any naked flames.
 - Have the gas system checked by a specialist.

Only use propane or butane gas.

Control and display elements

The control and display elements of the refrigerator are in the divider between the main and freezer compartments. The refrigerator features the following illuminated control and display elements:

Icon	Description
	ON/OFF button
	Operating with AC power supply
	Gas operation
	Operating with DC power supply
	Automatic mode (only RMD 8xx5)
	Setting the operating time of the freezer compartment frame heater
	Setting the temperature
	Temperature indication
	Indicator for malfunction reset button for gas malfunction
-	LED Turns red in the event of a fault. Turns blue when the refrigerator is in operation.

Depending on the side of the door hinge, the LED can be to the left or right of the controls.

Refrigerators for autonomous (gas) operation have two battery compartments in the control panel which are located on the left and right of the controls.

When the appliance is using the internal batteries, all the LED indicators with the exception of the display are off. The display flashes once every 15 seconds. When a button is pressed, the display lights up.



REFRIGERATOR

Using the refrigerator

- Make sure that you only put items in the refrigerator which may be kept at the selected temperature.
- Food may only be stored in its original packaging or in suitable containers.

Note:

- Before starting your new refrigerator for the first time, you should clean it inside and outside with a damp cloth for hygienic reasons.
- The cooling performance can be affected by:
 - The ambient temperature (e.g. when the vehicle is exposed to direct sunlight)
 - The quantity of food to be cooled
 - How often you open the door
- When using the refrigerator for the first time, there may be a mild odour which will disappear after a few hours. Air the living space well.
- Park the vehicle so that it is level, especially when starting up and filling the refrigerator before setting off on a journey.
- The refrigerator unit operates silently.
- Approximately one hour after switching on, the freezer compartment of the refrigerator should be cold. The refrigerator reaches its operating temperature after a few hours.

- Battery management systems switch off the power supply to the refrigerator as soon as the vehicle engine is switched off for longer than 30 minutes. The refrigerator requires a constant DC power supply to operate. If your vehicle has a battery management system deactivate it.

Open the doors of the main compartment and the freezer compartment to use the controls.

Switching on the refrigerator

- Ensure that the gas supply is turned on (only when using gas mode).
- Press and hold the  button for two seconds.
- The refrigerator starts with the last type of power selected.

Operating with AC power supply

- Press the  button.

Operating with DC power supply

- Press the  button.

Note: Only select with DC power supply (battery model) if the vehicle engine is running and providing sufficient voltage to the light system, or if you are using a battery monitor.

Gas operation



WARNING: FIRE HAZARD
Never operate the refrigerator with gas at petrol stations.

Note: When operating with LPG, the burner must be cleaned frequently (two or three times a year).

Ignition problems may occur at altitudes above 1000m. Switch to a different energy source.

Press the button .

The burner is ignited automatically.

Automatic operation (RMDX 8xx5 only)

Note:

- To avoid unintentionally switching to gas operation while refuelling, the automatic mode starts the gas operation only once the engine has been off for 15 minutes.
- Turn off the refrigerator or set it to a different operation mode, if refuelling lasts longer than 15 minutes.
- At altitudes above 1000m, ignition delays may occur. Change to a different type of energy when the ignition is not possible.



In automatic mode, the refrigerator selects the most favourable operating mode available itself.

Priority	Operating Mode
1	Solar (DC power)
2	AC power
3	DC power
4	Gas

Press the **A** button.

Opening the refrigerator door/freezer compartment door

CAUTION: Always close and lock the refrigerator before starting the journey.

- Press the lock button and pull the door up at the same time .

Fixing the locking catch in place

When the vehicle is parked, you can fix the locking catch in place. This makes it easier to open the door.

- Push the bolt under the locking catch upwards until it clicks into place.
- The door can be opened by pulling it.

Releasing the locking catch



- Push the locking catch downwards. The door can only be opened by pressing the lock button.

Locking the refrigerator door/freezer compartment door

- Release the locking catch, if applicable.
- Press the door shut until you hear it clearly click.
- The door is now closed and locked.

Selecting the temperature

Note: At ambient temperatures of +15°C - +25°C, select the centre position (three bars). The unit operates in the optimum power range.

- Set the required temperature with the  button. You can see the set temperature in the display 

One bar = lowest cooling capacity

Five bars = highest cooling capacity

Switching off the refrigerator

- Press and hold the  button for three seconds.
- The display goes out and the refrigerator is switched off completely.
- Shut off the valve in the vehicle and the gas supply to the gas cylinder.

Note: If you do not use the refrigerator for a prolonged period of time:

Unlock the locking mechanism of the door lock by pressing it inwards and sliding it forwards. When the door is then closed, there is a wide gap. This prevents mould from forming.
Remove the batteries from the battery compartment.

Positioning the shelves



WARNING: Children beware!
Two shelves are fixed in place to prevent children from climbing inside the refrigerator.

- **Only remove the shelves for cleaning purposes.**
- **Afterwards, refit the shelves in the same position and lock them in place.**

Removing the shelves

- Only fixed shelves: Undo the locking pins with a screwdriver.
- Press the two locks under the shelf inwards to release the shelf.
- Pull out the shelf.
- Only fixed shelves: Replace the locking pins again.

Inserting the shelves

- Insert the shelf into the required position.
- Press the locks under the shelf outwards to secure the shelf.
- Only fixed shelves: Replace the locking pins again.

Defrosting the refrigerator

Note: Never use mechanical tools or blow dryers to remove ice or to loosen objects stuck to the device.

Note: Over time, frost builds up on the cooling fins inside the refrigerator. If this layer of frost is about 3 mm thick, you should defrost the refrigerator.



REFRIGERATOR

- Disconnect the voltage and gas supply.
- Empty the refrigerator.
- Put a cloth in the ice compartment and the refrigerator to absorb any excess water.
- Leave the door open.
- The thawed water of the main refrigerator runs into a condensation container on the back of the refrigerator where it evaporates.
- Wipe both compartments dry with a cloth.

Operating with low ambient temperatures

Note: Do not attach the top winter cover while operating with gas. This prevents heat from building up and the fumes from the refrigerator can be extracted properly.

Note: Cold air can restrict the performance of the unit. Attach the winter covers if you experience a reduced cooling capacity at low ambient temperatures. This protects the unit from excessively cold air that might otherwise restrict its performance.

Attach the winter covers when the vehicle is cleaned from the outside or not used for a prolonged period of time.

- Regularly check that the ventilation grille is not obstructed by leaves, snow, or similar.
- Attach the winter cover to the lower grille.
- Only for direct/alternating current operation, not for gas operation: Attach the winter cover to the upper grille.

Operation at high ambient temperatures

At high outside temperatures in combination with high levels of humidity, condensation may form on the freezer compartment frame. The freezer compartment is fitted with a frame heater (12 V/3.5 W). Switch the frame heater on to prevent condensation from forming on the frame of the freezer compartment.

The frame heater is switched on continuously in the following operating modes (no display):

- AC operation
- Automatic operation

Note: Do not switch the frame heater to permanent operation when the refrigerator is being operated with gas. This could discharge the on-board battery.

Proceed as follows to switch on the frame heater:

- Press the  button to set the frame heater as follows:
 - Press the button once for a 2-hour setting; the temperature display shows one bar
 - Press the button twice for a 5-hour setting; the temperature display shows two bars
 - Press the button a third time for continuous operation; the temperature display shows three bars
 - Press the button a fourth time to switch it off; the temperature display goes off.

Cleaning and maintenance



WARNING: Always disconnect the refrigerator from the mains before you clean and service it.

Note: Do not use sharp cleaning agents or hard objects for cleaning.

Never use hard or sharp objects or blow dryers to remove ice or to loosen objects stuck to the device.

Do not use any mechanical tools or any other tools to speed up the defrosting process.

- Clean the refrigerator regularly and as soon as it becomes dirty with a damp cloth.
- Wipe the refrigerator dry with a cloth after cleaning.
- Check the condensate drain regularly.

Clean the condensate drain when necessary. If it is blocked the condensate collects on the bottom of the refrigerator.

Ensure that the ventilation grille in the outer wall of the motor home or caravan and the roof vent of the refrigerator are free of dust and contamination. This ensures that during operation, the generated heat can be dissipated, the refrigerator is not damaged and the cooling capacity is not compromised.



Troubleshooting

Fault	Possible cause	Suggested remedy
With AC operation:	The fuse in the AC mains is defective.	Replace the fuse.
	The vehicle is not connected to the AC mains.	Connect the vehicle to the AC mains.
	The AC heating element is defective.	Contact the authorised customer service.
With DC operation: The refrigerator does not work.	The fuse in the DC supply is defective.	Replace the fuse.
	The vehicle fuse has blown.	Replace the vehicle fuse in the DC socket (usually 15A) (Please refer to the operating manual of your vehicle).
	The vehicle battery is discharged.	Test the battery and charge it.
	The ignition is not turned on.	Switch on the ignition.
	The DC heating element is defective.	Contact the authorised customer service.
With gas operation: The refrigerator does not work.	The gas cylinder is empty.	Replace the gas cylinder.
	The gas valve is closed.	Twist the valve open.
	Air is in the supply line.	Switch the refrigerator off and on again. Repeat the procedure three or four times if necessary.
		If necessary, switch on the cooker if necessary and repeat the process on the refrigerator.



REFRIGERATOR















Troubleshooting (continued)

Fault	Possible cause	Suggested remedy
In automatic mode: The refrigerator is being operated with gas although it is connected to the AC mains.	The mains voltage is too low.	The refrigerator changes to AC power supply automatically as soon as the mains voltage is sufficient again.
The refrigerator does not cool sufficiently	The ventilation around the cooling unit is not sufficient.	Check that the ventilation grille is not obstructed.
	The evaporator is iced up.	Check whether the refrigerator door is properly closed. Check whether the seal of the refrigerator is seated correctly everywhere and is not damaged. Defrost the refrigerator.
	The temperature is set too high.	Set a lower temperature.
	The ambient temperature is set too high.	Remove the ventilation grille for a while so that warm air can escape quicker.
	Too much food at once was placed in the refrigerator.	Remove an item.
	Too much warm food at once was placed in the refrigerator.	Remove the warm food and leave it to cool down before putting it in again.
	The refrigerator has not been operating for very long.	Check the temperature again after four or five hours.



Displays for faults and beeps

Faults are indicated by the flashing of individual buttons on the control panel, a beep or a combination of both.

Display	Fault	Suggested remedy
 and  flashing, a beep is emitted for 20 seconds.	The AC heater element or the cooling unit is defective.	Contact the authorised customer service.
 and  flashing, a beep is emitted for 20 seconds.	The DC heater element or the cooling unit is defective.	Check that the ventilation grille is not obstructed.
 and  flashing, a beep is emitted for 20 seconds.	The burner or the cooling unit is defective.	
 flashes	The temperature sensor has no contact or is defective.	
With AC operation:  and  flashing, a beep is emitted for 20 seconds.	The power supply is not available or insufficient.	Check the AC power cable, the power supply and the fuse.
With DC operation:  and  flashing, a beep is emitted for 20 seconds.	The power supply is not available or insufficient.	Check the DC power cable, the power supply and the fuse.
With gas and automatic operation:  and  flashing, a beep is emitted for 20 seconds.	The burner flame is not ignited.	Check the gas supply (gas cylinder, gas valve) Press the  button once the fault is rectified.
In battery operation: Signal sounds every 15 s	Low voltage detection (internal battery)	Replace the batteries.



REFRIGERATOR

Displays for faults and beeps (continued)

Display	Fault	Suggested remedy
In battery operation: Automatic changeover from external to internal power supply does not function (loss of vehicle 12V power supply for electronic control unit)	Refrigerator does not work: Gas mode operation not possible even though batteries inserted.	Vehicle power supply was disconnected while starting gas mode. Note: Automatic switching does not occur during ignition. Switch the refrigerator off and on again.



ASPIRE 2 DUEL FUEL OVEN

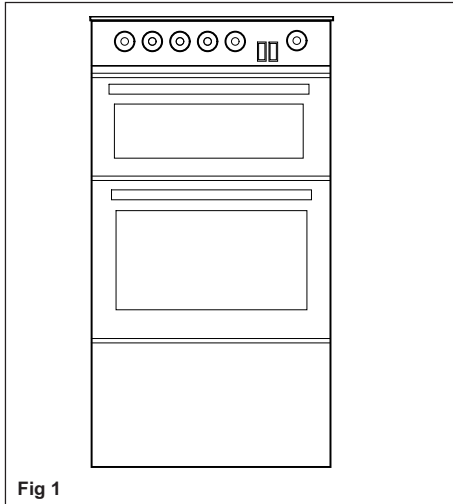

Fig 1

To light: Open door, push in the control knob and turn to full rate (240°C). Hold a lighted match or taper to the burner and push the control knob in and hold. The burner should ignite and the control knob should be held in for 10-15 seconds before release. If the burner goes out, repeat procedure holding control knob for slightly longer.

For models fitted with spark ignition the procedure is similar except that the burner

can be ignited by depressing the ignition button, which is located on the fascia. Ignition must be carried out with the door open, and if the burner has not lit within 15 seconds the control knob should be released and the oven left off at least one minute before a further attempt to ignite the burner.

Place the oven shelf in the required position and close the door. Set control knob to approximately 200°C and heat the oven for about 30 minutes to eliminate any residual factory lubricants that might impart unpleasant smells to the meals being cooked. A non-toxic smoke may occur when using for the first time so open any windows and turn on mechanical ventilators to help remove the smoke.

Although the oven does heat up quickly, it is recommended that a 10 minute preheat be allowed. The oven should be up to full temperature in about 15-20 minutes.

To turn off: turn the control knob until the line on the control knob is aligned with the dot on the control panel.

Shelf: The shelf has been designed to allow good circulation at the rear of the oven and are also fitted with a raised bar to prevent trays or dishes making contact with the back of the oven. To remove a shelf, pull forward until it stops, raise at front and remove.

Hotplate burners

Ensure the gas cylinder is turned on.

In the event of a gas smell turn off at the cylinder and contact supplier.

Flame supervision: each burner is controlled individually and is monitored by a thermocouple probe. In the event of the burner flames being accidentally extinguished, turn off the burner control and do not attempt to re-ignite the burner for at least one minute.

Note:

- Depending on the specification of your appliance it may be fitted with a glass lid which cuts the power to the hotplate and burners (gas and electric) if the lid is closed.
- Ensure the glass lid is in the open and upright position before turning on the hotplate burners.
- Not all models are fitted with the shut-off system.



OVEN, HOB & GRILL

Grill

Operation

To light the grill, push in the control knob and turn to full rate (see Fig 2). Hold a lighted match or taper to the burner and push the control knob in and hold. It is necessary to hold the knob depressed after the burner has ignited for approximately 10-15 seconds, to allow the thermocouple probe to reach temperature, before releasing the knob. Should the flame go out when the knob is released, the procedure should be repeated holding the knob depressed for slightly longer.

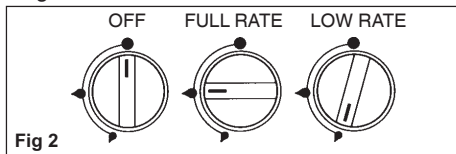

For models fitted with spark ignition the procedure is similar except that the burner can be ignited by depressing the ignition button, which is located on the fascia. If the burner has not lit within 15 seconds the control knob should be released and the burner left for at least one minute before a further attempt to ignite the burner.

For simmering, turn the knob further anti-clockwise to the low rate position.

To turn off: Turn the control knob until the line

on the control knob is aligned with the dot on the control panel. Always make sure the control knob is in the off position when you have finished using the hotplate burners.

IMPORTANT:

- Each burner will support pans from 10 to 22 cm diameter, care should be taken not to overload the appliance as performance may be reduced.
- The following pan sizes are the maximum we recommend: electric hotplate 18cm dia, auxiliary burner 20cm dia, semi-rapid burner 2x20cm dia or 1x22cm dia with 1x18cm dia.
- When using small pans the flames should not spread beyond the base of the pan as this will reduce the efficiency of the burner.
- Avoid old or misshapen pans as these may cause instability.
- The lid must be opened fully prior to using the hotplate burners.

Using the Electric Hotplate

Ensure the electricity is switched on. The hotplate control is numbered from 1 to 6. To turn it on, rotate the knob either clockwise or anti-clockwise to the required position. Position 1 is the coolest setting. To turn off, rotate the knob until the line or pointer on the knob lines up with the zero on the control panel.

The hotplate is a sealed construction and transfers heat through conduction. For maximum efficiency a correctly sized pan with a flat heavy gauge base should be used. Pan size should be the same or slightly larger (up to 2.5cm oversize).

The grill

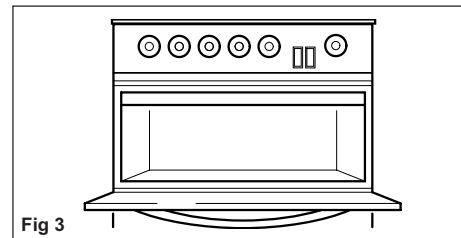

Fig 3

1. Ensure gas cylinder/supply is connected and turned on. In the event of a gas smell turn off at gas cylinder/mains and contact supplier.
2. To light: Open door, push in the control knob and turn to full rate (see Fig 2). Hold a lighted match or taper to the burner and push the control knob in and hold. The burner should ignite and the control knob should be held in for 10-15 seconds before release. If the burner goes out, repeat procedure holding control knob for slightly longer.
3. For models fitted with spark ignition the procedure is similar except that the



burner can be ignited by depressing the ignition button, which is located on the fascia. Ignition must be carried out with the door open, and if the burner has not lit within 15 seconds the control knob should be released and the grill left for at least one minute before a further attempt to ignite the burner.

4. Note: The grill must only be used with the door open.
5. On first use of the grill, it should be heated for about 20 minutes to eliminate any residual factory lubricants that might impart unpleasant smells to the food being cooked. A non-toxic smoke may occur when using for the first time so open any windows and turn on mechanical ventilators to help remove the smoke.
6. Although the grill does heat up quickly, a few minutes preheat is recommended.
7. Flame Failure Device (FFD): The grill burner is fitted with a flame sensing probe, which will automatically cut off the gas supply in the event of the flame going out. In the event of the burner flames being accidentally extinguished, turn off the burner control and do not attempt to re-ignite the burner for at least one minute.
8. It is normal for the flames on this burner to develop yellow tips as it heats up, particularly on butane.

9. A reversible grill pan trivet enables the correct grilling height to be achieved.

Fast toasting	trivet in high position
Grilling sausages	trivet in high position
Grilling steak/bacon	trivet in high position
Grilling chops, etc.	trivet in low position
Slow grilling	trivet removed
10. To turn off, turn the control knob until the line on the control knob is aligned with the dot on the control panel. Always make sure the control knob is in the off position when you have finished grilling.

Notes:

- The grill pan supplied is multi functional, for use in grill or oven.
- The handle design allows removal or insertion whilst the pan is in use.
- Always remove the handle when the pan is in use,
- The grill MUST only be used with the door open.

CAUTIONS:

- Children should be supervised to ensure they do not play with the appliance.
- Do not use foil on the oven shelves, as this creates a fire hazard and can hinder circulation of heat.
- Ensure gas cylinder/supply is connected and turned on. In the event of a gas smell turn off at gas cylinder/mains and contact supplier.

- Spillage on the surface of the lid should be removed before opening the lid.
- Do not use foil on the hob, as it creates a fire hazard.
- The glass lid has a tendency to snap shut towards the end of lowering. This is caused by the travel lock action of the hinges as it is activated. Make sure all fingers are removed from appliance when closing the lid.
- Glass lids may shatter when heated. Turn off the hotplate and allow it to cool before closing the glass lid.
- Turn off all burners and allow to cool before shutting the lid.

WARNINGS:

- When the grill is being used, accessible parts may be hot, young children must be kept away.
- The grill area can get hot when the oven is in use, even if the grill is switched off.
- Care should be taken when removing parts from the grill, i.e. use of oven gloves, and by making use of the removal grill pan handle.



OVEN, HOB & GRILL

DO'S AND DON'TS

DO read the user instructions carefully before using the appliance for the first time.

DO allow the oven to heat fully in order to expel any smells before introducing food for the first time.

DO clean the appliance regularly.

DO provide additional ventilation, such as opening windows near grill, cooker and oven when cooking.

DO remove any spills as soon as they occur.

DO use oven gloves when removing food shelves and trays from a hot oven.

DO check the controls are in the off position when finished.

DO NOT allow fats or oils to build up in the oven trays or base.

DO NOT use abrasive cleaners or powders that will scratch the surface of the hot plate and oven.

DO NOT under any circumstances use the oven as a space heater.

LEAKS

If a smell of gas becomes apparent, the supply should be turned off at the cylinder immediately.

Extinguish naked lights including cigarettes and pipes. Do not operate electrical switches. Open all doors and windows to disperse gas escapes.

Butane/Propane gas is heavier than air and

escaping gas will collect at a low level. The strong unpleasant smell of gas will enable the general area of the leak to be detected. Check that the gas is not escaping from an unlit appliance.

Never check for leaks with a naked flame; leak investigation should be carried out using a leak detector spray or soapy solution.

MAINTENANCE

This appliance needs little maintenance other than cleaning. All parts should be cleaned using warm soapy water. Do not use abrasive cleaners, steel wool or cleansing powders. When cleaning the burner ring it is essential that the holes do not become blocked. The control knobs are a push fit and can be removed for cleaning. They are interchangeable without affecting the method of operation.

THIS APPLIANCE MUST NOT BE MODIFIED OR ADJUSTED UNLESS AUTHORISED AND CARRIED OUT BY THE MANUFACTURER OR HIS REPRESENTATIVE. NO PARTS OTHER THAN THOSE SUPPLIED BY THE MANUFACTURER SHOULD BE USED ON THIS APPLIANCE.



Microwave (Daewoo)

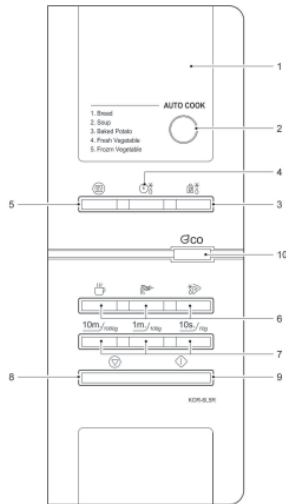

- 1 **DISPLAY** - Shows cooking time and power levels.
- 2 **AUTO COOK** - Use to cook or reheat common foods.
- 3 **WEIGHT DEFROST** - Defrost food based on weight.
- 4 **TIME DEFROST** - Defrost food by time.
- 5 **POWER** - Use to set power level.
- 6 **ONE TOUCH COOK** - Cook or reheat specific quantities of food.
- 7 **TIME SET BUTTON** - Set the cooking time and weight.
- 8 **STOP/CLEAR** - Stop the oven operation or delete the cooking data.
- 9 **START/+30 SEC** - Start the oven and also use set a reheat time.
- 10 **ECO** - Used to turn the AC power on the oven.

Operation Procedure

- Plug power supply cord into 230V AC 50Hz power outlet.
- Press eco button until beep sounds and display is turned on.
- After placing the food in a suitable container, open the oven door and put it on the glass tray. The glass tray and roller guide must always be in place during cooking.
- Close the door. Make sure that it is firmly closed.
- The oven door can be opened at any time during operation by pushing the door open button. The oven will automatically shut off. To restart the oven, close the door and then push the START button.
- The oven automatically cooks on full power unless set to a lower power level.
- The display will show ": 0" when the oven is plugged in, press and hold Eco button until display is turned on and beep sounds.
- Display will be returned to the ": 0" when the cooking time ends.
- When the STOP/CLEAR button is pushed during the oven operation, the oven stops cooking and all information

retained. To erase all information, push the STOP/CLEAR button once more.

- If the START button is pushed and the oven does not operate, check the area between the door and door seal for obstructions and make sure the door is closed securely. The oven will not start cooking until the door is completely closed or the program has been reset.
- Display turns off after 10 minutes.

Make sure the oven is properly installed and plugged into the electrical outlet.



ALDE HEATING - QUICK START GUIDE

ALDE 3020 COMPACT HE CONTROL PANEL

The Alde 3020 Compact HE control panel has two hard buttons and a non-capacitive, colour touchscreen interface. The soft buttons displayed on the screen are operated by touching the screen with your finger.

Important! Please read the operating instructions for the Alde 3020 Compact HE boiler before using the system.

STARTING THE SYSTEM



1. Both the control panel and boiler are off.
2. To start the system, press the Power button on the control panel. The Splash Screen is displayed and green LED is lit. The boiler will now start with the previously saved settings (factory settings by default).

The system will now be drawing variable 0.2–1 A of current from the 12 V supply.

Standby Screen

The Standby Screen is displayed after the Splash Screen. This screen contains useful information about the status of your heating system.

NB: If Standby Screen is set to “Dark” in Backlight settings, the Standby Screen will not be displayed, the screen will be dark unless touched.

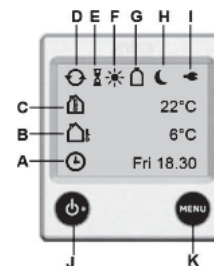

- A. Clock is enabled. Day of the week and time shown.
- B. Outdoor Temperature. [Optional outdoor temperature sensor required.]
- C. Room Temperature. Measured at the control panel. [Optional discrete room temperature sensors available.]
- D. Central heating circulation pump is active.
- E. Delayed Start/Cycle is enabled.
- F. Day Mode active.
- G. Gas Cylinder Status. Full/empty and active EisEx shown.
- H. Night Mode active.
- I. 230 V supply. If not displayed, the boiler is not receiving 230V supply.
- J. Power button. Press to switch system on-off. Lit green LED indicates system is on.
- K. MENU button. Press to access Main Menu from Standby Screen or Settings Menu. [Additional accessories required.]

ALDE HEATING - QUICK START GUIDE



MAIN MENU

Press MENU button to access the Main Menu from the Standby Screen or Settings Menu. The screen will revert to the Standby Screen after 30 secs if untouched.

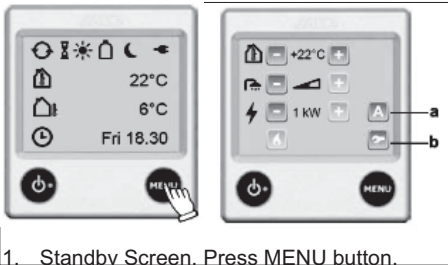

1. Standby Screen. Press MENU button.
2. Main Menu.
 - a. What's Activated Menu. [Not displayed if no activated functions are detected.]
 - b. Settings Menu



Desired Room Temperature

The desired room temperature can be set from 5 to 30°C, in 0.5 increments.

Tip! The World Health Organisation recommends a room temperature of 18–24°C for healthy living.

NB: If Day or Night Mode are active, the temperature cannot be adjusted, the Plus and Minus buttons will be greyed out.

1. The current desired room temperature is displayed.
2. Adjust by pressing Plus or Minus button.



Domestic Hot Water

The Alde boiler stores 8.4 Litres of hot water as standard. If the hot water cylinder is empty, the air is heated but no damage can result.

Tip! In a good summer, for example, lower the desired temperature on the control panel to around 10°C. The central heating will not circulate (unless the temperature drops to 10°C), but you can still control hot water.

NB: If Day or Night Mode Sans Hot Water are active, the hot water cannot be adjusted, the Plus and Minus buttons will be greyed out.

1. Hot Water Ignore. Volume bar empty. No attempt is made to heat hot water specifically. This saves energy when the freshwater is drained down.
2. Hot Water Normal. Volume bar half-full. Hot water is heated to greater than 50°C.
NB: If Circulation Pump is set to Continuous, this option will not be available.
3. Hot Water Boost. Volume bar full. Central heating circulation is disabled for 30 mins. Hot water is heated to greater than 65°C. After 30 mins the system reverts to Hot Water Normal.
4. Adjust by pressing Plus or Minus button.



Electric Heating

Check that 230V supply is displayed on the Standby Screen. The Alde boiler is programmed to use power economically and there are times when it may use no power at all, even if set to 3 kW.

1. Select Off, 1, 2 or 3 kW electric heating. More power equals better performance, but may be restricted by the current (amps) limit on the electric hook-up.
2. Adjust by pressing Plus or Minus button.
Max current draw from 230 V supply is 4.5 A on 1 kW, 9 A on 2 kW, 14 A on 3 kW. If the electric supply has unstable voltage, the amperage will also fluctuate.



Gas Heating

The Alde boiler is programmed to use power economically. The gas burner has two stages, shifting dynamically between low or full flame. There are times when it may use no power at all, even if gas heating is selected.

1. Press the Flame button to select gas heating. Green is on, blue is off.
Use both gas and electric heating for best performance.



ALDE HEATING - QUICK START GUIDE



Climate Control

The AC button is displayed when a Truma Aventa Comfort air-conditioning unit is connected to the Alde control panel. This allows fully automatic climate control, with the heating and air-conditioning working in unison.

- Select the desired room temperature as normal.
- Press the AC button. Green is on, blue is off. The heating and air-conditioning will actively maintain the desired room temperature.

Alde recommends using the 3010-346 discrete room temperature sensor for accurate climate control. It should be located where the heating and air-con have a balanced effect on temperature.

SHUTTING DOWN THE SYSTEM

To save energy, the control panel only updates the boiler after the last adjustment is made. Wait 10 secs before shutting down the system to ensure the boiler is updated.

1. Press the Power button again. The screen goes dark, the green LED is unlit. The system is off.

SETTINGS

To learn more about the Settings Menu and programmable features of your Alde heating system, the complete operating instructions can be downloaded from www.alde.co.uk.

To store programmable features between sites, the optional Alde 3010-420 AA battery backup is required.

SETUP

How you set up your system will depend on what accessories are installed and your user preferences. To get you started, here's how to setup some of the more common features.

Restore default factory settings

Before using the system for the first time, restore default factory settings. Your control panel may have been tested by the dealer or installer, and some settings may have been changed unintentionally.

1. Press Tool button to access the Settings Menu (bottom right in Main Menu).
2. Press down arrow, until Reset button is displayed.
3. Press the Reset button to proceed.



Setup 12V circulation pump in expansion tank

To use the 12V circulation pump in the expansion tank, you must set it up. This is not a default factory setting. NB: This only applies if you have the 12V circulation pump in the expansion tank.

1. Press Tool button to access the Settings Menu (bottom right in Main Menu).
2. Press down arrow, until Installed Accessories button is displayed.
3. Press the Installed Accessories button to access the menu. Find and tick "Optional Pump" by pressing the box. Next, find and untick "Main Manual 12V".





Setup Standby Screen for bedtime

The backlight on the Standby Screen can be disturbing if the control panel is visible from your bed. It can be inverted for white text on black background.

1. Press Tool button to access the Settings Menu (bottom right in Main Menu).
2. Press down arrow, until Backlight button is displayed.
3. Press Backlight button, select Inverted to proceed.



Setup Antimicrobial function

To actively kill *Legionella*, setup the Antimicrobial function. At 2:00 every night, the hot water will be heated to over 65°C for 30 mins. This further reduces the risk of *Legionella*.

1. Press Tool button to access the Settings Menu (bottom right in Main Menu).
2. Press down arrow, until Antimicrobial button is displayed.
3. Press Antimicrobial button to proceed.



TROUBLE SHOOTING

Any error messages will be displayed on the Standby Screen. Error messages can be cleared by switching off 12 V supply to the boiler for 10 secs.

The system is completely dead, the control panel is blank

- Check the 20 mm T3.15 Amp glass fuse in the boiler. This is located under the lid of the black plastic service hatch, in a green plastic fuse holder.
- Check the 12 V supply to the boiler, it should be above 12 V.
- Check the 12 V cable is plugged into the boiler. Check the cable is plugged into the Alde control panel.

The boiler will not ignite on gas, but no error message

- The system may not need to use gas heating if also using electric heating.
- The fluids in the boiler may already be at operating temperature.

The boiler will not heat on 230 V electric

- Check the circuit breaker and any 230 V fuses.
- Check that any 230 V fused spurs are on (they will often have an LED indicator and 230 V fuse).

- Check the 230 V supply (also indicated on the Standby Screen).
- The fluids in the boiler may already be at operating temperature.

No hot water

- Check that Hot Water Ignore is not activated on the Alde control panel.
- Check that Continuous pumping is not activated on the Alde control panel.
- Check for other conflicting settings on the Alde control panel or restore factory defaults.
- Check the water pump and cold water supply to the boiler.

No central heating

- Bleed the system of air.
- Check the fluid level in the expansion tank.
- Check that the circulation pump is responding.
- Check that hot water boost is not activated on the Alde control panel.
- If electric heating is not being used, set it to "Off" on the Alde control panel.
- Use gas and electric heating for best performance.
- Check that top and bottom vents in the furniture are not obstructed.
- Check the condition of the heat transfer fluid.



ALDE HEATING - QUICK START GUIDE

- Most vehicles will reach a comfortable temperature within 40 mins, in non-extreme conditions.

Circulation pump is noisy

- Bleed the system of air.
- Check the fluid level in the expansion tank.
- If the inline pump, check speed dial on pump is set to 2-3.

“Panel failure 1” & “Panel failure 2”

- Moisture is trapped in the control panel.
- Remove the Alde control panel from the vehicle and air in a warm, dry place overnight.

“Gas failure”

- Out of gas or gas is not igniting.
- Check the gas cylinder is full. Try a different gas cylinder, ensuring it is propane gas.
- Check the gas regulator and any isolation valves are open and not frozen.

“Overheat red fail” or “Overheat blue fail”

- Bleed the system of air.
- Check the fluid level in the expansion tank. It should be 1cm above min mark when cool.
- Check the correct circulation pump is installed, selected and responding.

- 12 V supply to the boiler dropped to 7 V momentarily. Check 12 V supply for stability.
- Wait 30 minutes for the fluid to cool down.

“Overheat PCB”

- Failsafe in boiler has triggered.
- Check the fluid level in the expansion tank. It should be 1 cm above the Min mark when cool.
- Check the boiler compartment is ventilated and that the vents are unobstructed. Do not place stowage in the boiler compartment.

“Fan failure”

- Combustion fan speed too low after multiple attempts. Bearing may be stiff after a period of disuse.
- Check for instability in 12 V supply.

“Connection failure”

- Loose connection between Alde control panel and boiler.
- Unplug cable at the control panel and boiler, then carefully plug back in.
- Check there is slack on the cable at the control panel, but not excessive weight from free-hanging/unmanaged cable.

“Window open”

- Optional window sensor has triggered, gas heating is suspended. Automatically clears and gas heating resumes when window is closed.

“3rd Party Panel C. Fail”

- Break in comms between Alde control panel and third party control panel.
- Check the cable between the Alde control panel and third party control panel.
- Third party control panel is installed in software but not fitted.
- Untick "Third Party Panel" in Installed Accessories Menu.

“Low battery”

- 12 V supply to boiler has dropped below 10.5 V, possibly causing system brownout.
- Automatically clears when 12 V supply reaches 11 V.

“No match Heater/Panel”

- EM interference from 230 V power, if cables are bundled together.
- Conductive dirt in socket. Plug Alde control panel cable into the alternative TIN bus sockets.

If problems persist, please contact Alde, or your dealer or installer.

For our frequently asked questions, or download all instruction manuals, please visit our web site at: www.alde.co.uk



THETFORD C-260 CASSETTE TOILET INTRODUCTION

The Thetford Cassette Toilet is a high quality product. It is user-friendly, meets high quality standards and gives you all the convenience of home.

Before operating and using this toilet we advise you to read the manual completely. Keep this manual in a safe place for future reference.

For the latest version of the manual please visit www.thetford-europe.com

Possible toilet options

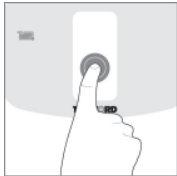

Some toilets are fitted with extra options. To check which options are available, press the flush button on the control panel.

The following symbols can light up:



Waste Pump-Out system; transfers waste from the waste-holding tank into the vehicle's central waste tank.



Electric Blade; electrically opens or closes the blade.



Electric Ventilator; draws unpleasant odours away from the waste tank to the outside of the vehicle.

Main Parts



Standard

1 Cover - 2 Seat - 3 Swivelling toilet bowl - 4 Blade handle to open/close blade - 5 Control panel - 5a Flush button - 5b Waste-holding tank level indication (1 level or 3 levels; dependent on model) - 6 Pull handle - 7 Pour out spout - 8 Cap with measuring cup - 9 Automatic pressure release vent - 10 Vent button - 11 Sliding cover - 12 Blade opener - 13 Waste-holding tank mechanism - 14 Wheel - 15 Service door

Options

18 - Filter for electric ventilator - 19 Location waste pump-out system



THETFORD TOILETS

Preparing for use

This Cassette Toilet has a waste-holding tank of 17.5L. Before using your toilet, it is vital that you add toilet additives to these tanks. Check the correct dosage on the additive package. Then add $\pm 3L$ of water to the waste holding tank.

Use of your toilet

Turning the bowl



You can turn this bowl to a desired position (max $\pm 90^\circ C$). Close the cover and use both hands to rotate the bowl as illustrated.

Opening the blade



The toilet can be used with the blade open or closed.

To open the blade, slide the blade handle sideways as illustrated. Make sure you always close the blade completely after use.

Electric Blade (if applicable)

Press the flush button to activate the control panel. Then push the Electric Blade button. The blade will open or close electrically.

Flushing the toilet

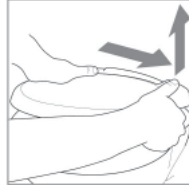

Press the flush button once to activate the control panel. Then press the flush button for several seconds to flush the toilet.

Electric Ventilator (if applicable)

By activating the control panel, the Electric Ventilator will start automatically; it will shut off automatically after about 5 minutes. The Electric Ventilator button will flash to show that this function is active. To stop the ventilator, press the Electric Ventilator button. Press the button again to re-start the ventilator. To optimise its function, activate the Electric Ventilator before you use your toilet.

Ordinary toilet paper can cause clogging. Use Aqua soft toilet paper instead. This toilet paper is super-soft, dissolves quickly, prevents clogging and makes it easier to empty the waste-holding tank.

Level indication

You can check whether your waste-holding tank has a 1-level or a 3-level indication. Make sure the tank is empty and place it back properly. Then activate the control panel. If no level indication light lights up,

your toilet has a 1-level indication. It will only indicate a full tank. If a green level indication light immediately lights up, your toilet has a 3-level indication. It will indicate empty, half full and full.

Emptying the tank

Waste holding tank

When the red light of the level indicator on the control panel lights up, you need to empty the waste-holding tank. Remove the tank via the service door. Then take it to an authorised waste disposal point. Empty the waste holding tank via the pour out spout.

Tip: To empty the tank without splashing, press and hold the vent button with your thumb while the pour out spout is pointing downwards.

Waste Pump-out system (if applicable)

By activating the control panel, this button automatically lights up. Press the button to empty the waste-holding tank into the vehicle's central waste tank. The button flashes while the waste is being pumped and stops flashing when all waste has been transferred. ($\pm 1.5L$ of waste is left). If the central waste tank is too full (only measured when this tank has a level indicator), the button flashes rapidly and no pump-out is possible until you have emptied the central waste tank.



CLEANING AND MAINTENANCE

It is important to clean this Cassette Toilet regularly. You will prevent limescale and ensure optimal hygiene. Clean the inside of the bowl with toilet bowl cleaner and a soft brush and use bathroom cleaner for the outside of the toilet.

Note: Never use household cleaners to clean your toilet. These may cause permanent damage to the seals and other toilet components.

Remove seat & cover

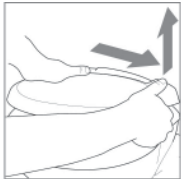

To clean your toilet thoroughly, remove the seat and cover. First push the seat and cover together to the right, then lift them up.

Winter use

You can use your toilet as normal in cold weather as long as the toilet is situated in a heated location. If this is not the case and there is a risk of frost, we advise not to use your toilet. Make sure you completely empty the waste-holding tank.

Preparing waste-holding tank



1

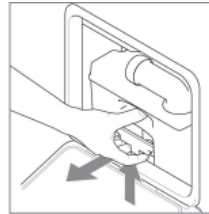

2

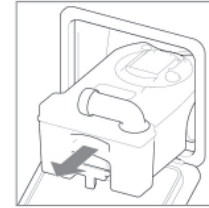

3



4



5



6



7



8



9

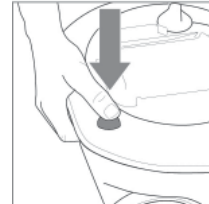

10

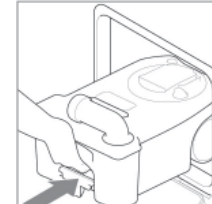

11



12



THETFORD TOILETS

Preparing Electric Ventilator (if applicable)

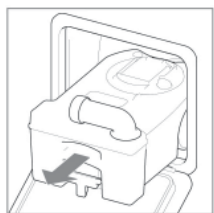

13

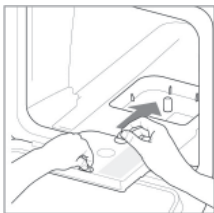

14

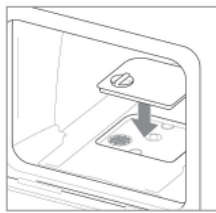

15



16

Emptying waste-holding tank

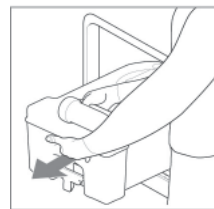

17

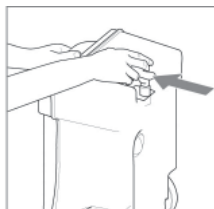

18

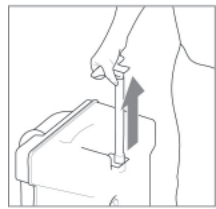

19

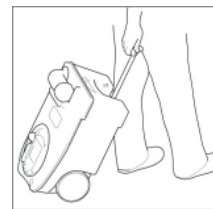

20



21

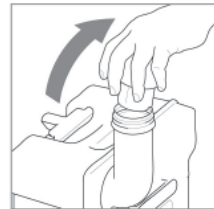

22



23



24



25

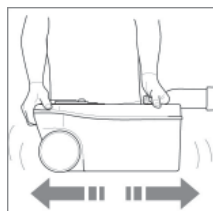

26



27

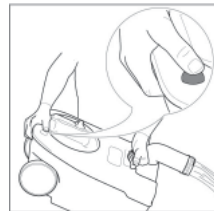

28

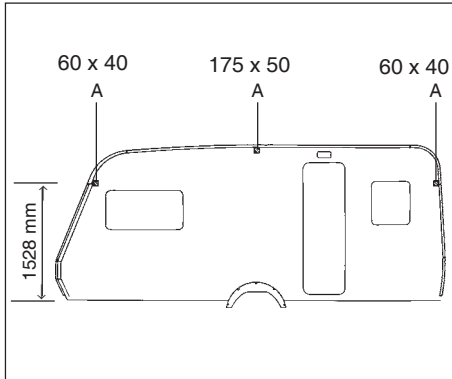

AWNING FIXING POINTS

In all Alaria Caravans fixing blocks for the awning brackets are now fitted as per the diagram (position A). The centre block is determined from centre of wheel arch and just below awning rail.

The end fixing points are just above window height front and rear, approximately 60mm long x 40mm, 1528mm above the underside of the floor (i.e. from top of skirt).

Care must be taken when fixing the brackets and a suitable sealant used.

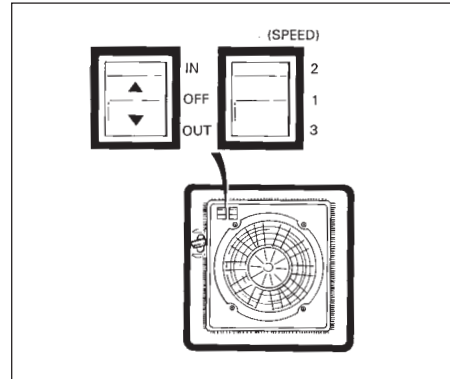

12 VOLT ROOF MOUNTED EXTRACTOR FAN

The fan is a double glazed rooflight. Its side operating mechanism allows a completely free central opening with built-in fixed ventilation when closed.

TILT & SLIDE ROOFLIGHT

To open - turn the handles to release the rooflight. Push it upwards and slide it towards the front of the caravan.

Before travelling ensure the rooflight is in the fully closed and locked position.

A fully adjustable flyscreen and black out screen are built into the frame.



ANTENNA

STATUS TV ANTENNA

OPERATING THE SYSTEM

Travelling

When positioning the Antenna Dome please allow for the following:-

DO NOT TRAVEL:-

- With the Antenna raised
- With the Antenna set for vertical signals

To reduce the possibility of damage when travelling, have the antenna pointing towards the rear of your caravan/motor home.

Operating

1. Loosen the Mast Locking Collar and raise the antenna.
2. Determine whether the TV transmissions are horizontal or vertical and position accordingly.
3. Switch On the Amplifier and the LED will illuminate and check the gain is set to MIN by rotating the button anti-clockwise.
4. Rotate the antenna.

RED - Poor signal - keep turning.

YELLOW - getting better - slow down.

GREEN - Signals located, ready to GO.

5. If there's no GREEN increase the Gain and repeat the 360 degree rotation.
6. Once the transmitter has been located increase the Gain to MAX.

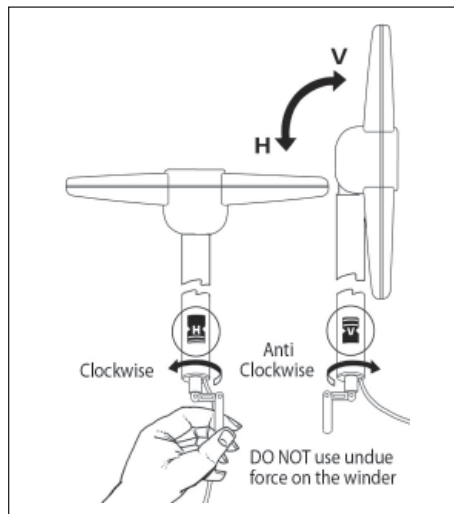

7. Turn on your television set and tune in. This will be necessary at all new locations.
8. Secure the Antenna by hand tightening the Mast Locking Collar.

IMPORTANT

You may detect more than one transmitter. Choose the position that gives you the most channels when tuning in your TV.

In poor signal areas the LED may only glow YELLOW.

In strong signal areas you may need to reduce the gain by rotating the Control anti-clockwise.

Removing the Antenna

A permanently fitted Status can be easily removed leaving only the Mounting Foot and rubber gaiter.

1. Unplug the antenna lead from the Amplifier.
2. Loosen the Mast Locking Collar and lift off whilst feeding out the mast, coaxial cable and plug.
3. Push the Blanking Cap supplied into place.

IMPORTANT - The Blanking Cap is a temporary seal and is not recommended for long term use.

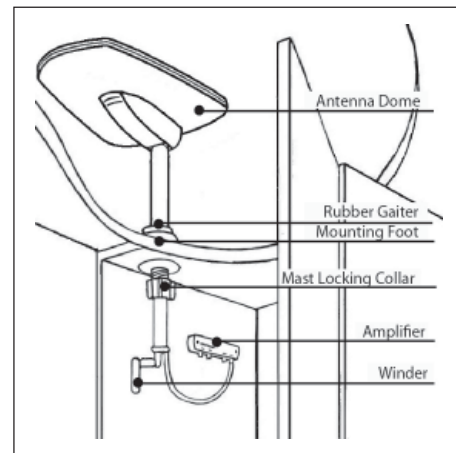



Signal	Symptom	Action
Very Poor	No picture or sound, TV freezing, severe pixilation, break up and picture drop out	Check the amplifier gain is set to maximum (rotate clockwise). Check antenna alignment which must be directed at the transmitter. Ensure the antenna's polarity is correct, whether horizontal or vertical. Bypass the amplifier by following "Short Hook-Up Test 1"
Poor	Moderate pixilation and sound distortion	
Medium	Minor pixilation will not receive all channels	
Good	Stable picture, good sound quality will receive all channels	N/A
Strong	Possible pixilation, picture break up and drop out.	Reduce the amplifier gain (rotate anti-clockwise). Rotate antenna AWAY from the transmitter.
Very Strong	No picture or sound, TV freezing, severe pixilation, break up and picture drop out.	Rotate antenna AWAY from transmitter. Switch 'OFF' the amplifier and turn the gain control to maximum (rotate clockwise).
After performing any of the 'Actions' above you must re-tune your TV		

Guarantee

The Status Antenna has a return to base guarantee against defective parts and workmanship for two years or a period determined by the vehicle manufacturer. This does not include any malfunction resulting from improper use, incorrect installation, accidental or malicious damage. To support your guarantee claim a dated Proof of Purchase will be required.

This does not affect your statutory rights. Any queries concerning warranty please contact ourselves.

Fault Finding

The following are some of the key areas we suggest you check which generally solve the most common problems encountered with the operation of the Status antenna.

Coaxial Connections

It is critical that all connections in the system are fitted correctly and only quality plugs have been used.

Coaxial Cable

Sharp bends, kinks and hot surfaces can easily damage coaxial cable and should be avoided. Coaxial cable, if placed in close proximity to electrical cables, transformers or other pieces of electrical equipment, may pick up electrical interference causing picture quality to deteriorate, especially in poor reception areas. Excess cable should be removed and NOT coiled as this may cause picture distortion. An inspection of the routing of the cable is highly recommended to ensure all is correct.

Gain Control

In normal use the button should be rotated clockwise for maximum. In strong signal areas the amplification may need to be reduced. To reduce amplification rotate the button anti-clockwise until picture quality improves. The button rotates through 270 degrees from MAX to MIN



ANTENNA

LED Light

Should the LED on the Amplifier not light, firstly check there is power to the unit. Secondly check the polarity is correct. Otherwise contact ourselves for further assistance.

Short Hook Up - Test 1

This test isolates the wiring from the Amplifier through to your TV/Radio points.

Unplug the coaxial plugs from the 'TV' sockets of the Amplifier and using your TV fly lead with Converter 1 supplied. Connect your TV to the Amplifier.

Please ensure the Antenna Dome is plugged directly into the 'ANT-IN' socket of the Amplifier and switch on. Tune in your TV for the strongest signal.

If the picture quality improves the fault lies with the wiring of the system between the Amplifier and the TV outlet socket.

Short Hook Up - Test 2

This test isolates the Amplifier by connecting your TV direct to the Antenna.

Unplug the Antenna from the Amplifier and connector Connector 2 supplied to the plug on the cable end. Using your TV flylead connect the antenna directly to your TV. Tune in your TV for the strongest signal.

If the picture quality improves the fault lies with the Vision Plus Amplifier.

Antenna Dome Co-axial Cable

Check the routing of the coaxial cable from the Antenna Dome to the Amplifier. Check to ensure there are no kinks or trapped cable or if there are loops of surplus cable which could be affecting performance.

Customer Help Line

Should you still be experiencing difficulties and require assistance, please do not hesitate to contact us at the address below.

MAINTENANCE

Gaiter

We suggest you periodically check the gaiter for any signs of damage or for wear.

If the rubber is caught by overhead obstructions it may rip or tear which would allow water to work its way into the fabric of the roof.

Over an extended period of time the gaiter will wear at the contact area with the mast. Should the gaiter begin to fail the signs will be small amounts of water dripping down the outside of the mast, however, the design of the Gaiter and Mounting Foot ensures that water cannot work its way into the fabric of the roof. Should this problem occur contact ourselves for a replacement unit.

Spares & Repairs

Should you require any parts for replacements or repair please log on to www.gradeuk.co.uk or contact ourselves on 0115 986 7151.

Vision Plus

8 Finch Close

Lenton Lane

Nottingham

NG7 2NN

0115 986 7151

info@visionplus.co.uk

www.visionplus.co.uk



LED LIGHTING

LED lighting is non replaceable.

Please refer to electrics section, control panel, for information on dimming functionality.

CD/RADIO/MP3

Your caravan is fitted with a Pioneer CD/ Radio Unit. Please refer to manufacturers manual for further functionality and instructions.



SECURITY/ALARM AND TRACKER

STINGER 310 ALARM

If your caravan has been fitted with a Stinger 310 Alarm, this provides comprehensive protection for your caravan when parked or coupled to your tow vehicle, as well as protecting the contents. The alarm system is controlled by a key fob, which can also switch the awning light on/off. If you insure with the Caravan Club, K. Drewe (Insurance) or Caravan Guard Insurance, you should be eligible for a discount on your premiums.

OPERATION





Each Stinger 310 is supplied with two key fob style radio controllers, which are used to operate the alarm system.

USING THE ALARM

The Stinger 310 comes complete with a PIR internal movement sensor that detects body movement within the vehicle. If you are leaving pets within the vehicle, the system should be armed without the PIR sensor active.

The Stinger 310 alarm also incorporates an electronic tilt and motion sensor which works automatically and does not need adjustment for normal use.

When the alarm is triggered the siren will sound for 2 minutes. Following the 2 minute period the alarm will then deactivate for 15 seconds and then rearm. The alarm siren can be turned off at any point by pressing the key fob arm/disarm button.

	LED TORCH BUTTON	Press and hold the button to use the torch.
	ARM/DISARM BUTTON	Press and release the button to arm the alarm (one beep). Press and release the button to disarm the alarm (two short beeps). To arm the alarm without the PIR movement sensor, press and hold the button and release after you hear one beep followed by two beeps.
	AWNING LIGHT BUTTON	Press and release the button to turn the awning light on or off. (Please note that this light must be switched on with its own switch before it can be switched off then back on using the key fob.
	PROGRAMMING MODE BUTTON	Press and hold the button for 10 seconds to access the 3 programming modes.

PHANTOM PRO 3 TRACKER - (THATCHAM CERTIFIED CAT6)

For vehicles fitted with a factory fit Phantom Tracker, it is strongly recommended to familiarise yourself with the operation and working of such, if you have an internet connection the following link provides a great video guide to how your tracker works.
<https://phantom.uk.net/app-help-video>

Your vehicle will also be dispatched with the quick user guide, please retain this and store it with your handbook for further reference.

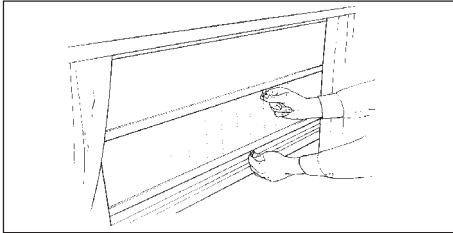

FLYSCREENS AND SUNBLINDS

Important: Blinds should be checked for holes and tears when you take delivery of your caravan. Failure to report a fault at this stage will result in a claim under warranty being rejected.

OPERATING INSTRUCTIONS (Quasar/ Lexon only)

Flyscreen

Pull the flyscreen fully down and gently push the crossbar towards the window so that it locates in the retaining “cut out” within the rear channel of the lateral guides. To release, gently pull the crossbar downwards and toward you and allow the tension of the spring mechanism to rewind the flyscreen upwards.

DO NOT RELEASE THE HANDLE – causing the flyscreen to “whiplash” upwards – as this will cause damage to the spring mechanism.

Sunscreen

The front channel of the lateral guides has a number of “cut outs” to enable the sunscreen to be retained at various heights – look inside the lateral guides to locate these. To raise or lower the sunscreen follow similar procedure as with the flyscreen.

TENSION ADJUSTMENT

The tension adjustment clips are located at the left side of the cassette – the top one is for the flyscreen and the lower one for the sunscreen.

Insert screwdriver into tension clip, apply gentle inward pressure and rotate tension clip one or two clockwise turns to increase tension or anti-clockwise to reduce tension. Gently release the inward pressure to enable tension clip to re-engage into its internal ratchet. Check tension and, if necessary, repeat until the crossbars return to their top positions without too much tension or assistance. **DO NOT OVERTENSION.**

Note: It is not recommended that the window blinds are retained in the “down” position whilst the caravan is being towed.

WINTERISATION

The flyscreen/sunscreen should NOT be left in the “down” position through the winter as this may cause the spring mechanism to lose tension.

However, to rectify this, gently pull crossbar downwards and toward you then allow the tension remaining in the mechanism to rewind, when it stops pull the crossbar downwards and upwards five or six times to restore correct tension.

Should the blinds not retract fully, please follow Tension Adjustment instructions.

DOOR FLYSCREEN

The flyscreen runs in a bespoke cassette housing with inbuilt track.

To Open/Close from inside or outside pull the handle that runs the entire length of the screen across to the desired position.

Cleaning

Use a damp cloth and, if necessary, a normal household cleaner without abrasives or solvents.



FLYSCREENS, BLINDS & ROOFLIGHTS

Opening and closing the panoramic rooflight

Opening the rooflight

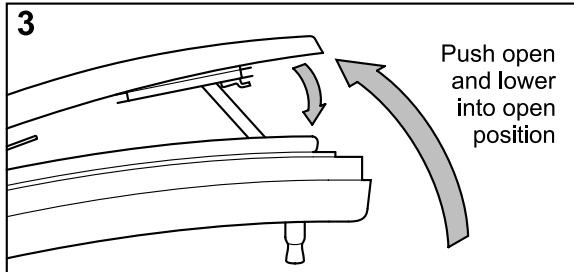
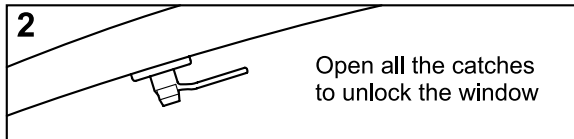
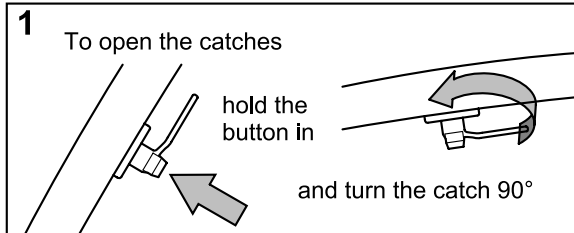

Closing the rooflight

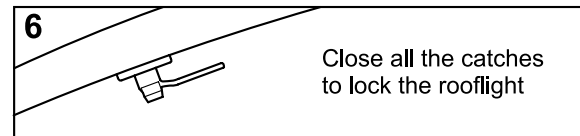
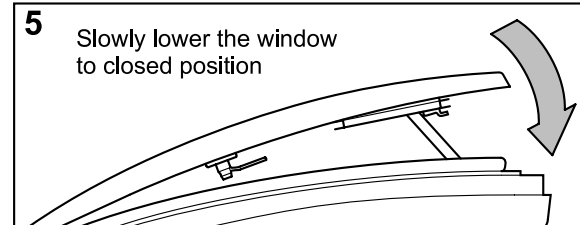
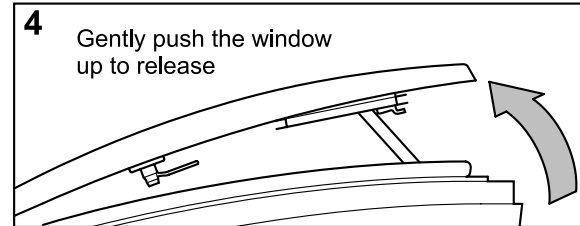



WINDOWS

The windows on your caravan are made from acrylic. If you consider the instructions below, the windows will stay in good shape for a long time. Windows also require periodic maintenance and checking by your dealer at least once per year.

Operation



When the vehicle is in motion all windows must be fully closed.



Never use the blinds in direct sunlight. If you use the blind in direct sunlight, even for a short period, heat will accumulate between the window and blind possibly causing damage to the window such as bending/ballooning.

Your windows are equipped with either handles with buttons or handles with stays. Please observe the following operating instructions.

Handles with buttons - Always push the button when opening/closing the handle.

Stays in step version - You will hear clicks when opening the window. Every click represents the position in which a window can stay opened. When closing the window, you must open it till the end and then close. Do not try to close it without first opening it as wide as it goes, as this will damage the stays.

Stays with knob screw - Always make sure to unscrew the knob before closing the window.

Catches - The catchers enable three positions of the window. The open position is where the handle is open placed on the outer part of the catcher. If the handle is placed in the middle of the catch, this is the position for ventilating. The closed position is where the handle is closed on the inner part of the catch.

Cleaning

1. Cleaning window profiles

To clean coloured and anodized profiles, use a soft cloth and water without any aggressive cleaning solvents. The use of any chemicals and abrasive cleaners could damage the surface of the profile.

2. Cleaning windows

Never use abrasive or corrosive substances or solvents on windows, such as turpentine, spirit or dishwasher detergents, as they will damage the acrylic and/or print. We recommend cleaning with a generous amount of water or mild cleaner intended for use on acrylic. There are some specialist plastic cleaning agents such as Plexus or Brilliantize which can be used if preferred. Cleaning with a dry cloth can damage the acrylic and leave scratches; always use a moist sponge or moist soft cloth.

Acrylic material can get scratched very easily. Please consider the above instructions for cleaning, so that you will not cause scratches or other damages.

Temporary Condensation

Condensation can appear on the window or between both panes. This is a normal occurrence that appears because of different temperatures inside and outside, moisture and the properties of acrylic itself. Condensation will disperse after some time. This doesn't mean that there is something wrong with the window or that it is leaking. With a properly ventilated vehicle you can in most cases prevent condensation.

How to overcome condensation

1. Improve ventilation

- Leave rooflight open or use a self-ventilating rooflight.
- Add to the ventilation by fitting more improved ventilators.
- Put windows onto night vent position.
- Leave doors open between compartments.

2. Help yourself tips

- Do not wash crockery last thing at night, it creates more moisture in the air.



WINDOWS/SUNROOF AND BODY

- (b) Do not boil water last thing at night and empty all water from kettles, etc.
- (c) Remove flowers or vases containing water from sleeping quarters.
- (d) Keep temperature at night to a minimum (hot air contains water vapour).
- (e) Increase ventilation to above normal in inclement or very wet weather.

Note: You cannot expect to eliminate condensation completely but following the hints above will help towards a more comfortable environment.

WARNING: Never clean windows or sunroof with a high pressure washer. The rubber seals that protect your caravan from water ingress are not designed to withstand water applied at high pressure and will fail under exposure to such, the use of pressure washers to the seals is deemed as misuse, not covered by your warranty. Please also note that a carwash can cause scratches and other damages that the manufacturer cannot be held liable for.

Sunroof Blind

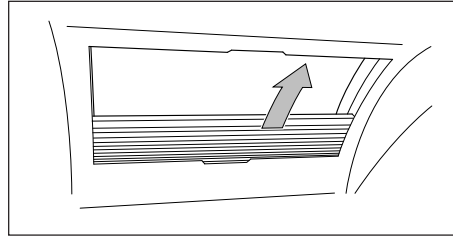

Models fitted with sunroofs come with an integrated pleated blind, in closed position this is located at the lower edge of the sunroof surround, to close the blind simply pull the aluminium channel upwards to the desired location using the finger grip notches as a guide.

WARNING: The blind should be closed slowly so you do not trap your fingers in the return edge of the plastic surround.

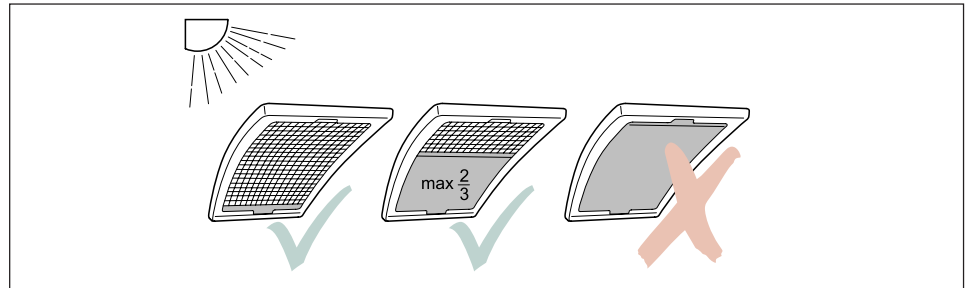

Note: In direct sunlight the blind should not be left closed. It is advised that the blind is left fully open, but if the user feels necessary this can be closed to a maximum 2/3 of the windows overall opening.

Sunroof Exterior Care

The sun roof should be checked as part of your annual service, the rubber seal should be visually inspected to ensure it is in good condition, and any build-up of leaves or debris behind the seal should be cleaned away with a soft brush.

Beware if working at height to access the sunroof this should only be done by a competent and confident person with the appropriate health and safety precautions in place.



CLEANING THE CARAVAN BODY

It is wise to wash the caravan body regularly in order to maintain its good looks. Do not use aggressive cleaning materials as this will damage the paintwork over time. 'T Cut' or other similar cleaning compounds should only be used occasionally for stubborn marks. We suggest that a good quality car wax, applied at least once a year, will enhance the paintwork and ease the cleaning operation.

ABS Panels

ABS components need to be washed, waxed and taken care of like a car. Most stains or marks can be removed with mild detergent, but more stubborn marks may require a (fine grit) rubbing compound such as T-cut.

To help keep your ABS components looking almost like new, it is wise to wash the parts monthly (or more frequently) using mild detergent, but avoid using strong alkaline (e.g. tri-sodium phosphate) or acidic cleaners or abrasives. Waxing the components once or twice a year with a good grade paste wax will help to maintain the colour and finish.

BADGES

Resin coated badges are now being widely used within the caravan industry. Their upkeep is simple, use soap and water only to clean them. Under no circumstances should abrasive cleaners or solvent based solutions be used on them.



BUNK BEDS/FRONT BEDS

BUNK BED ASSEMBLY

The following step by step guide illustrates how to assemble the bunk bed.

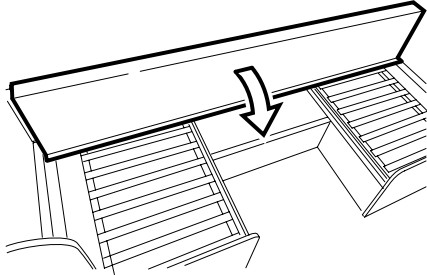

1. Pull the top edge of the bunk towards you.

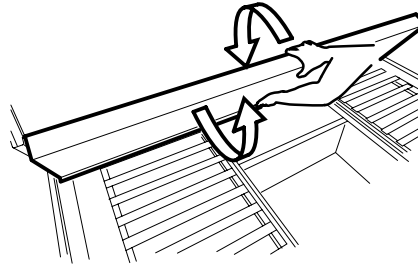

2 & 3. With your left hand on the bottom edge, lift upwards and towards you, while your right hand keeps the bunk steady.

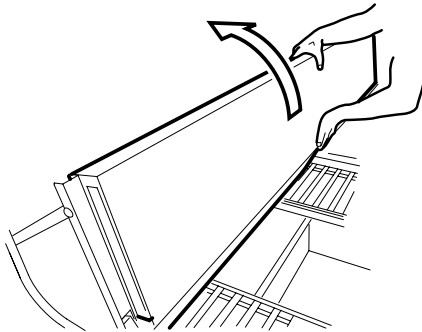
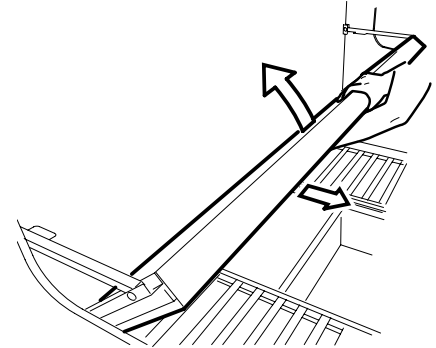

4 & 5. As the left hand passes the pivot point allow the right hand to slowly lower the bunk into the rest position.

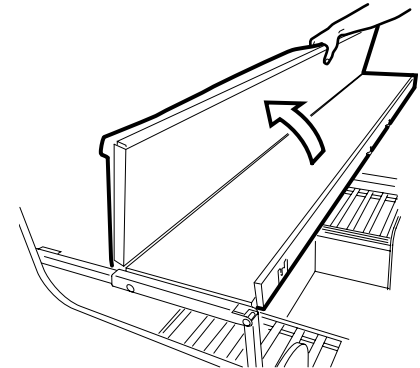
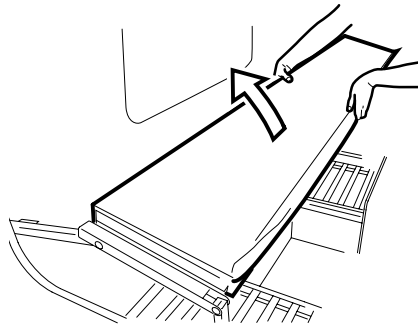

6. Fold the two part bunk into position.

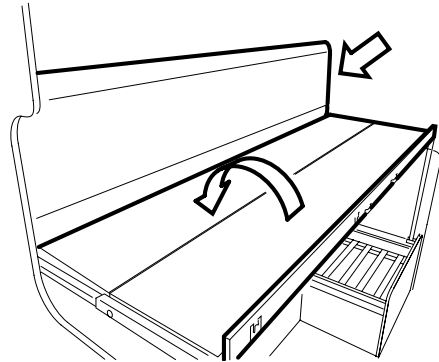

7. Fit the safety boards into position.

FRONT BEDS

There is a luxury L-shaped lounge set up with pull out bed at the front of the vehicle for added comfort.

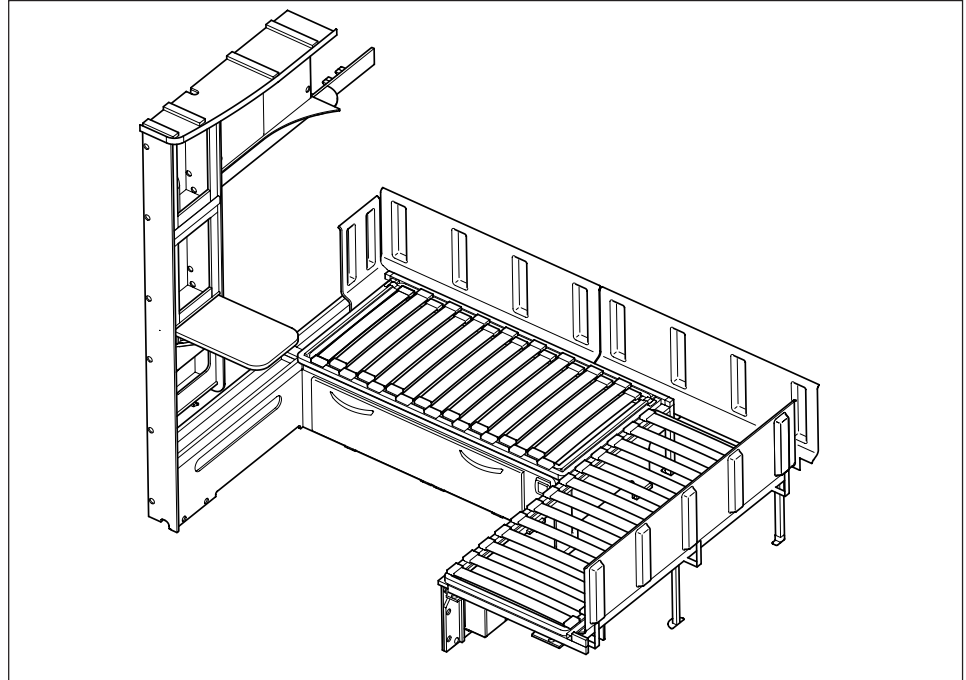



HOW TO MAINTAIN FURNITURE IN A CARAVAN

HOW TO PROPERLY MAINTAIN THE FURNITURE IN A CARAVAN

About Humidity

Air contains moisture – this is called humidity. The higher the temperature of the air the more water it is able to hold. Air at 20°C can hold a lot more moisture than air at 10°C. The term 'relative humidity' describes how much moisture air contains at a given temperature. 100% relative humidity means the air is holding as much moisture as it can at that temperature.

The more humid the air is in your caravan, the more energy it takes to warm your van because it is also warming the water in the air. This means it will be more expensive to heat!

A good range of indoor humidity for comfort and health is between 30-60% during cooler months of the year. Mould is likely to occur if the relative humidity indoors is 70% or more for long periods of time. Keeping humidity levels under 50% also helps to minimise or control dust mites.

It can be fun to buy a low cost humidity meter from a hardware store and track how humid the air in your caravan is. You might be surprised at how quickly it can change, from morning to night and as the weather changes.

About Condensation

When the humidity is high inside a van and it is cold outside the water vapour condenses on cold surfaces. What causes dampness and condensation in your van?

- Lack of adequate ventilation and/or heating.
- Water coming in from the outside through leakage, seepage or open windows
- High levels of moisture/water vapour being produced inside the caravan

Humid air and condensation can also be generated by things people do on a daily basis.

- Cooking Up to 3 litres per day
- Showers and baths 1.5 litres per person
- Washing dishes Up to 1 litres per day
- Unflued gas heater 0.5-1.0 litre per hour of use
- Breathing, active adult 0.2 litres an hour per person
- Breathing, adult asleep 0.02 litres an hour per person

Because your Furniture pieces are made from wood or wooden materials they require attention and care to maintain their beauty over time.

Moisture in air can cause damage to furniture. Wood expands or contracts with an increase or decrease in the relative humidity in the air. A 40% -60% relative humidity is tolerable. Beyond this level, wood can expand. The damages can be quite visible if the relative humidity is higher than 80% for a long time. To prevent damage, assure the relative humidity of air is not too high for a long time by ventilating the van, using dehumidifiers or water absorbent substances.

When wood is wet, wipe it dry. Do not just wait for the sun to dry it. The longer the water stays on the surface, the more damage it can do.

How to keep your caravan dry and avoid condensation

There are lots of things YOU can do to minimise dampness and condensation in your caravan.

The key actions:

- Provide ventilation and/or reduce relative humidity of air by , particularly in moisture-prone periods of the year (especially winter time) and when the moisture is produced in the van (cooking, shower)
- Reduce the amount of moisture produced in the van
- Increase heating to raise the temperature of the air and the cold surfaces

HOW TO MAINTAIN FURNITURE IN A CARAVAN



On dry days open some windows to allow humid air to ventilate out of the van. It is better to open a few windows a little throughout the whole caravan. This helps the air to move through the caravan. One window open wide may not be as effective. Try to do this as often as possible (at least once a week), but keep windows closed on wet days as damp air may increase indoor humidity.

High temperature can also damage the surfaces of your furniture. Protect them with protective table pads or place-mats when utilizing extremely hot utensils or dishes.

Do Not's

- use detergents or chemical cleaners on your furniture this may damage the finish,
- drop the pieces,
- expose the furniture to extreme hot, cold, rain, humidity or salinity,
- leave surfaces wet with beads of water standing

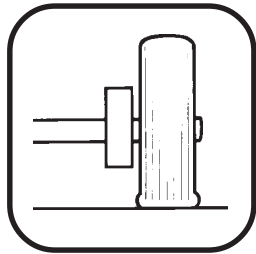

AL-KO CHASSIS & TYRES

Chassis	128
General Maintenance	129
Tyres	130



AL-KO CHASSIS & TYRES

All caravans are released with a hard copy of the latest Al-Ko chassis handbook, please retain this and store it along with your Alaria Handbook and refer to it for issues relating to the chassis operation and maintenance.

For advice relating to:

Chassis

Running Gear

Braking System

General Maintenance

The latest version can also be found online at: www.al-ko.co.uk/pages/original-2.html



CARAVAN CHASSIS

HANDBOOK FOR VEHICLES ON
THE AL-KO CARAVAN CHASSIS



GENERAL NOTES ON MAINTENANCE

Chassis

This is an uprated chassis at 2000Kg.

Tyre Wear and Damage

The legal requirements for tread depth on motor vehicles apply also to caravans. In order to equalise wear it is suggested that wheels be balanced and changed around from time to time.

It is dangerous to neglect tyre damage and should you detect a blister, rupture or cut exposing the casing, or if it has suffered a violent impact (for example against a kerb), such that there is a risk of internal damage, it is advisable to have it examined by a tyre specialist as soon as possible.

Wheels

The condition of wheels should be checked regularly particularly for distortion of flanges and the wheel dish. Wheels damaged or distorted, or having wheel bolt seatings cracked or deformed must not be repaired.

Couplings

1. Clean and grease spherical seat, bearing parts and pivot pins regularly.
2. Thoroughly examine all moving parts for wear and correct functioning.
3. Couplings should never be drilled.

Towing Ball

The automobile towing ball should measure 50mm maximum and 49.5mm minimum (DIN 74058). If the ball is found to be worn it should be replaced immediately.

Overrunning Device

The device housing is packed with grease on assembly, but will require periodic maintenance to ensure smooth operation of the braking system.

1. Regrease the shaft bearings via the grease nipples provided at 3000 mile intervals and before storage.
2. Ensure correct functioning of all pivot pins and levers and oil regularly.

Jockey Wheel

Lubricate wheel and screw thread periodically.

Brake Linkage

All moving parts should be lubricated periodically to ensure their satisfactory operation.

It is recommended that all brake linkage threads are liberally smeared with grease for protection and as an aid to future adjustment of the system.

Corner Steadies

The screw and pivot pins should be lubricated periodically to ensure their satisfactory operation.

Braking System

At 500 miles then every 3000 miles or 1 year check and adjust brake linkage to compensate for any stretch of the bowden cables.

Check and adjust wheel brakes to compensate for wear.

IMPORTANT: When replacing the wheels you should tighten the nuts in rotation diagonally, taking care to tighten them equally.

Please see Preparing for Road for torque settings.

CHECK THE WHEEL NUTS BEFORE STARTING EVERY JOURNEY

IMPORTANT NOTICE:

The caravan is manufactured for towing behind road cars and the 4 x 4 "off road" type of passenger car derivative. THE CARAVAN IS NOT SUITABLE FOR TOWING BEHIND COMMERCIAL VEHICLES.



AL-KO CHASSIS & TYRES

TYRES

PREPARATION

Tyres & Tyre Pressure

Safe driving and handling when towing a caravan is very important and one major factor which is frequently overlooked is the tyres. Look after your tyres properly and you will improve the safety and behaviour of your car and caravan.

Check the Pressures

Whatever tyres are fitted to the towing car and caravan it is essential to the safety and stability of the combination that all tyres are correctly inflated. This is a 'golden rule' of motoring and of caravanning in particular. Pressures should be checked when the tyres are cold, not warm during or just after a run when they will be higher. Never reduce pressures when tyres are warm as they could be too low when they cool down.

The tyres specified by the caravan manufacturer are satisfactory for towing in the UK and are rated up to 80mph (130kph) at the maximum design weight of the caravan. In certain countries overseas it is legal to tow at higher speeds. If it is intended to visit such countries and tow up to the higher speed limits then it is important that the suitability of the tyres is first checked with a caravan dealer.

Tyres & Pressures

The tyres fitted, and the pressures needed, vary from model to model. Check the Service Handbook for specific recommendations for your model.

The speed limit for towing a caravan in the U.K. is 60mph. If a tyre needs to be replaced you must ensure that you refit a tyre of the same specification. The correct pressure for your car tyres will be found in the car handbook.

Fit the Right Tyres

As with all road vehicles it is always advisable to have the same type of tyres on all wheels i.e. both on the towing vehicle and the caravan but it is recognised that caravans and trailers will frequently have a different type from the towing vehicle.

If a wheel or tyre has been changed the replacement has to be of the same type of construction and size as on the other wheels.

General Recommendations

Because caravan tyres and wheels are rarely the same as those on your car you must not attempt to use the car wheel on your caravan if you should have a puncture.

Check your tyres regularly but particularly when the caravan has not been used for a long time. Vehicles such as caravans if not used in the winter should be thoroughly inspected prior to re-use during the summer months. Look particularly for any signs of age deterioration in the tyres such as sidewall cracking and carcass deformation. Tyres on a stationary vehicle, particularly if parked in coastal areas, always age and crack more quickly than those which are run frequently and, if your caravan is going to stand for a long time it is a good idea to cover the tyres with old sacks, etc. to shield them from direct light and, if possible, to jack the weight off the tyres. If in doubt at all about your tyres have them checked immediately by a tyre distributor.

WARNING: Prior to any journey the condition of the tyres should be inspected. The NCC recommend that tyres are replaced seven years from date of manufacture at the very latest.

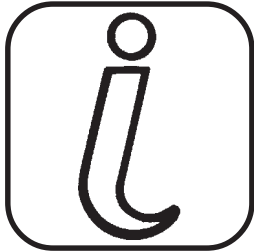

GENERAL DATA

Wiring Diagrams	132
Light Bulb Replacements	138
Security	138
Owners Club	139
Owners Warranty	139
CRiS	140
Winterization Guide	141



GENERAL DATA

ALARIA

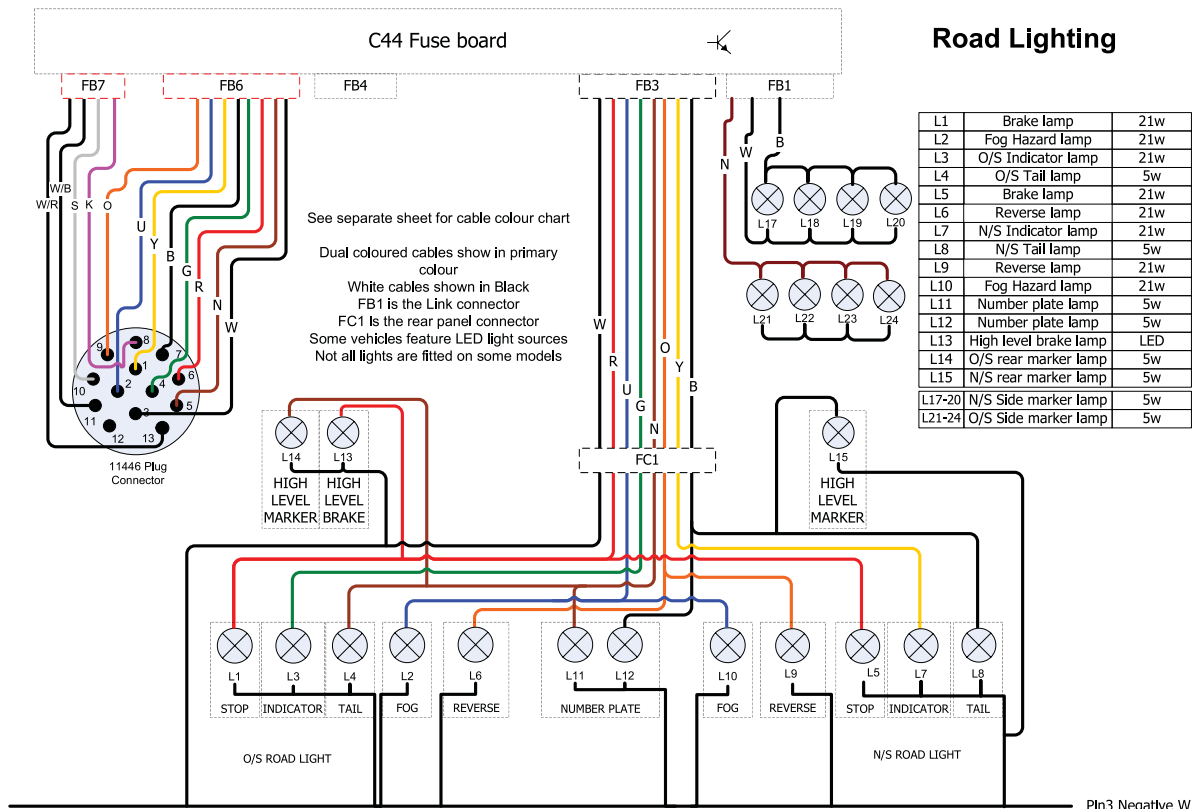



ALARIA

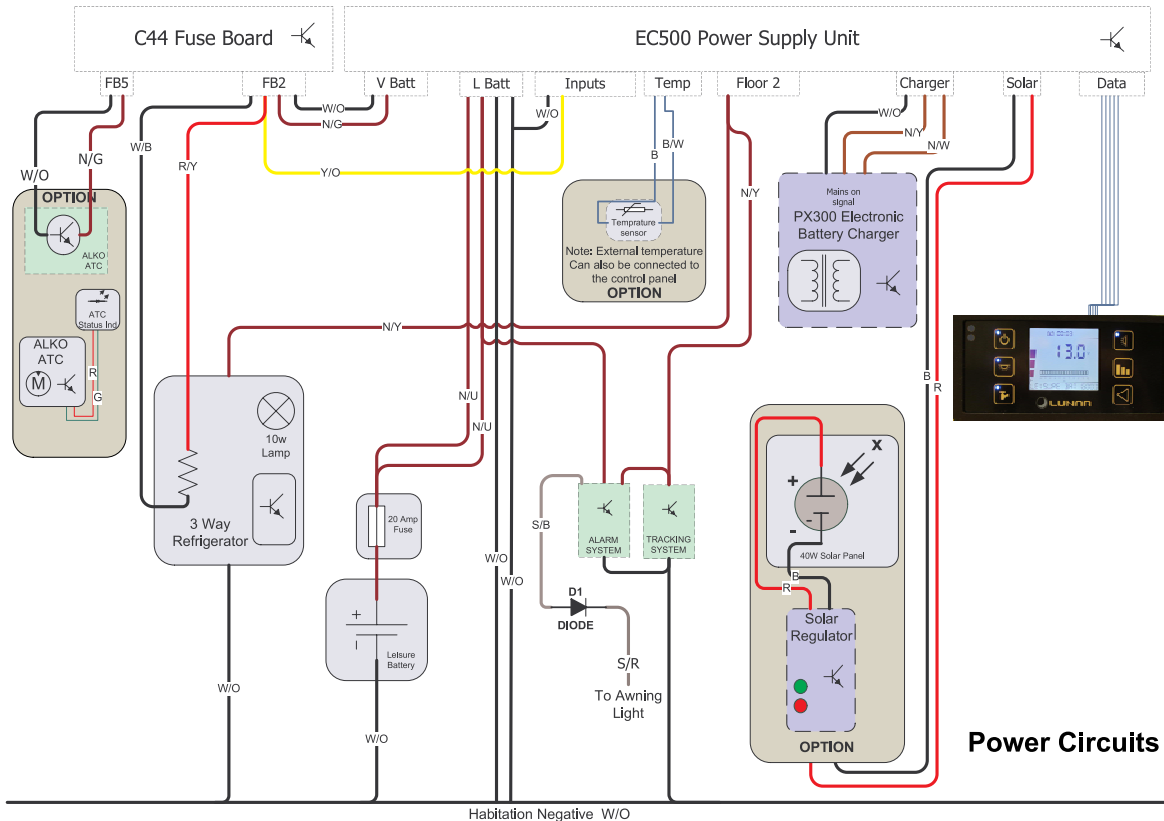

Power Circuits



GENERAL DATA

ALARIA

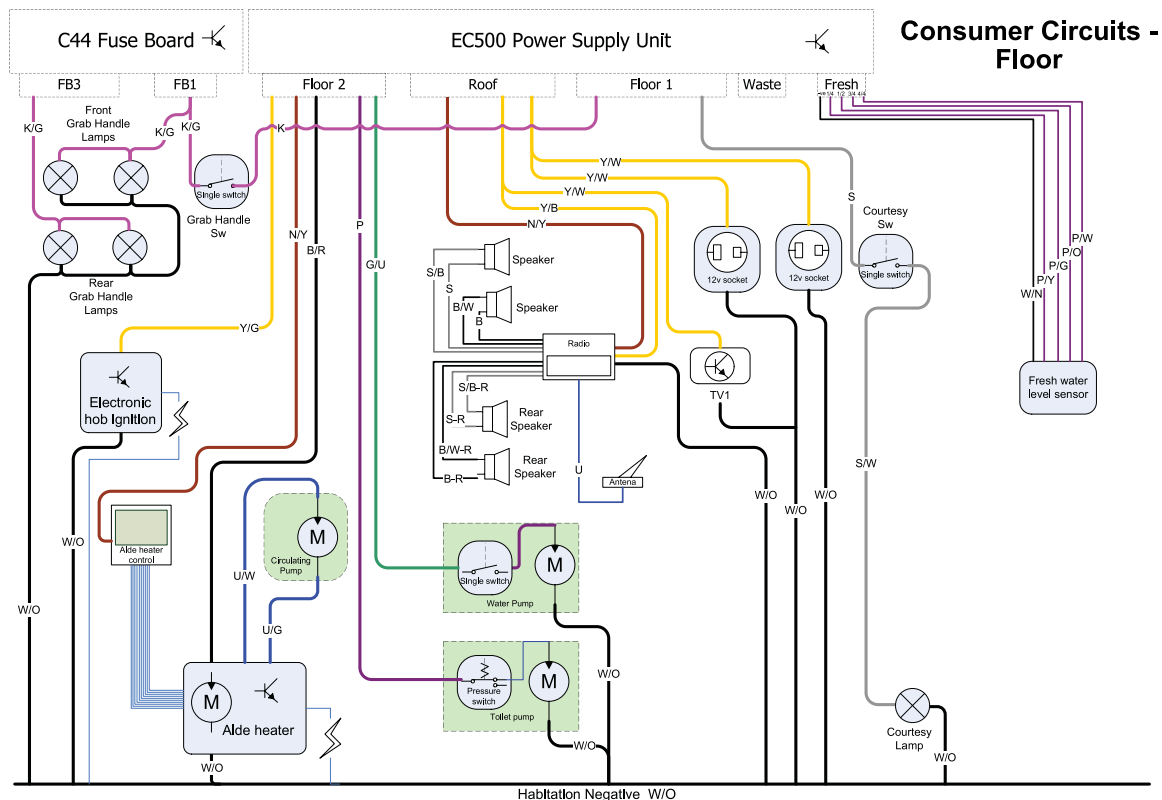



ALARIA

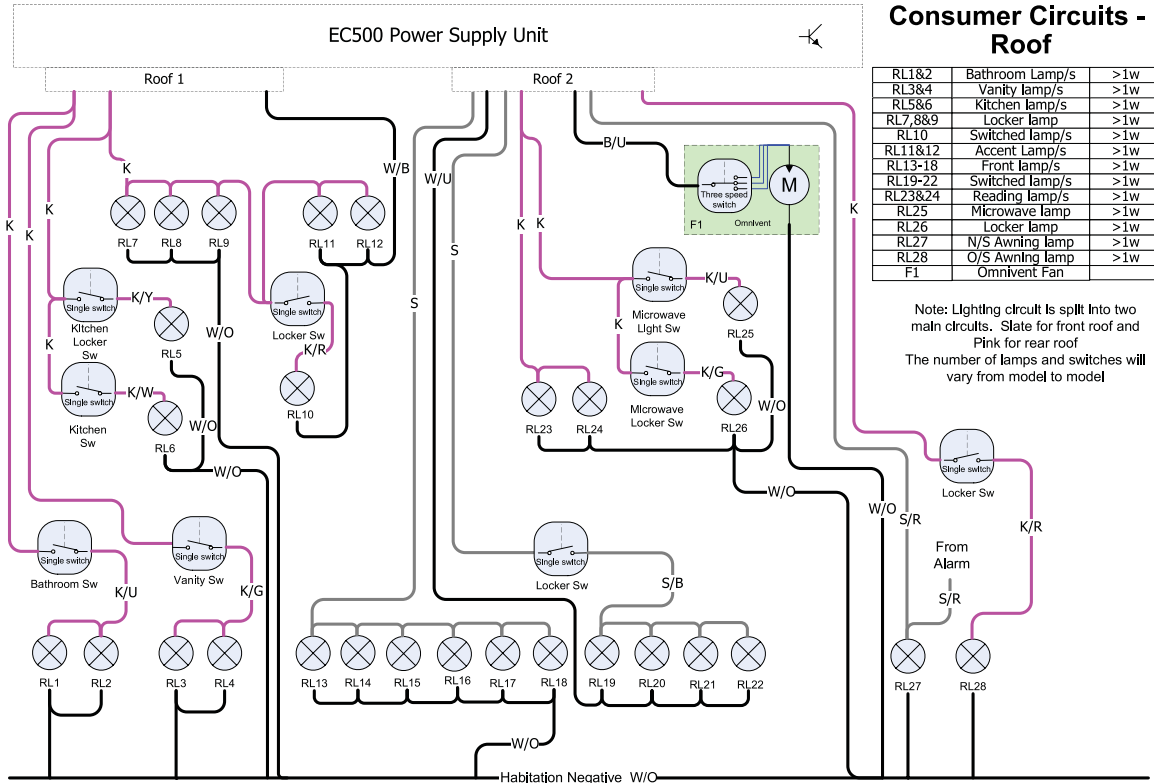

Consumer Circuits - Roof

RL1&2	Bathroom Lamp/s	>1w
RL3&4	Vanity lamp/s	>1w
RL5&6	Kitchen lamp/s	>1w
RL7,8&9	Locker lamp	>1w
RL10	Switched lamp/s	>1w
RL11&12	Accent Lamp/s	>1w
RL13-18	Front lamp/s	>1w
RL19-22	Switched lamp/s	>1w
RL23&24	Reading lamp/s	>1w
RL25	Microwave lamp	>1w
RL26	Locker lamp	>1w
RL27	N/S Awning Lamp	>1w
RL28	O/S Awning Lamp	>1w
F1	Omnivent Fan	

Note: Lighting circuit is split into two main circuits. Slate for front roof and Pink for rear roof
The number of lamps and switches will vary from model to model



GENERAL DATA

ALARIA

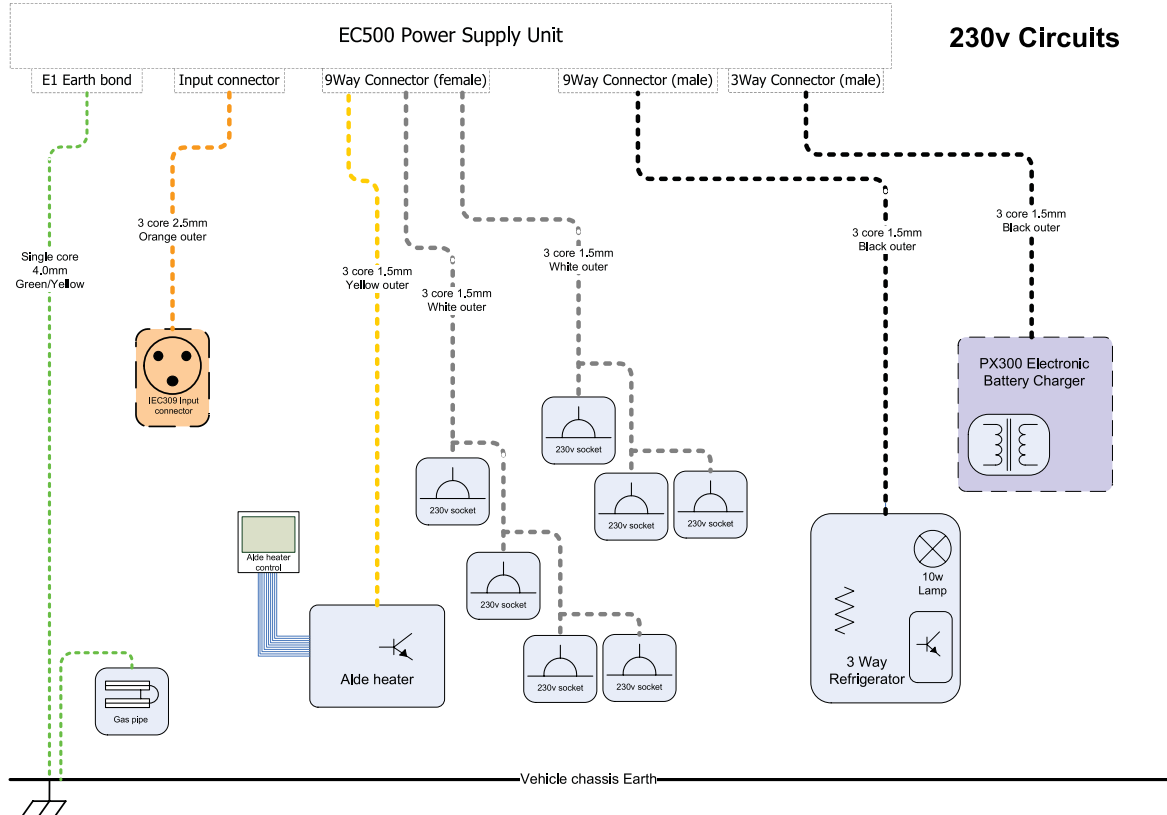



ALARIA



Y/U

Example

Yellow cable with Blue stripe

Cable Colour Chart

12v Cable Colours

B	BLACK
N	BROWN
R	RED
O	ORANGE
Y	YELLOW
G	GREEN
U	BLUE
P	PURPLE
S	SLATE GREY
W	WHITE
K	PINK

230v Cable Colours

B	BLACK
N	BROWN
W	WHITE
O	ORANGE
Y	YELLOW
G	GREEN
U	BLUE



GENERAL DATA

LIGHT BULB REPLACEMENT

Brake/side light	Twin 21W/5W, 12V
Front side light	5W, 12V
Side light (white/red)	5W, 12V
Indicator light	21W, 12V
Reversing light	21W, 12V
Fog light	21W, 12V
High level brake light	12V LED
Number plate light	5W, 12V
Mains Reading Light	12V LED (None replaceable bulb)
Ceiling Light	12V LED (None replaceable bulb)
Toilet ceiling light	12V LED (None replaceable bulb)
Awning Light	12V LED Strip (None replaceable bulb)
Cocktail Cabinet	12V LED (None replaceable bulb)
Spot light	12V LED (None replaceable bulb)
Mood light 195mm	12V LED Strip (None replaceable bulb)
Bunk light	12V LED (None replaceable bulb)
Courtesy light	12V LED (None replaceable bulb)
Reading lamp	12V LED (None replaceable bulb)
Front interior corner light	12V LED (None replaceable bulb)

Note: Where non replaceable bulb is stated this may refer to a LED strip or housed/encased bulb that cannot easily be accessed or replaced with a single bulb, the above is intended as a guide only, where replacements are required please refer to your dealer for advice on the best possible replacement procedure for the light fitting that requires replacing.

SECURITY

Ensure that you lock all windows and doors when leaving your caravan. Fit a towbar hitch lock or a wheel clamp -consult your dealer on all safety and security recommendations.

Keep your gas cylinder locked when leaving your caravan.

Many devices are available to alarm your caravan. It is a good idea to mark your caravan in a secret place -this will help the police to identify it should it be stolen.

Caravans can be stolen from storage compounds, motorway service areas and even your own premises, so it is always wise to be vigilant at all times. Ask your dealer about details on all security aspects.



LUNAR OWNERS CLUB

Now you are the owner of a Lunar caravan why not join the Lunar Owners Club.

This is an independent club run and organised by owners.

Lots of opportunities exist to make new friends at social gatherings and Rallies both Regional and National.

A leaflet regarding the Owners Club is within the wallet, if it is not please contact Lunar and a copy will be sent to you.

Alternatively for further information please visit the Lunars Owners Club website at: www.lunarsownersclub.net

OWNERS WARRANTY

All Alaria Caravans are supplied with a 6 year body shell warranty and a 3 year manufacturer's backed warranty from the date of purchase. The warranty is conditional on annual servicing being carried out within 60 days either side of the anniversary of the purchase date, except the third service which should be carried out prior to the third anniversary date of the final year.

Validating your warranty

Your Alaria warranty commences on the day your new caravan is purchased. It is important that as an owner you complete the "Validate your Warranty" section located on our website. This activates your Alaria warranty <http://www.lunarcavans.com/validate-you-warranty>.

By registering your details we will be able to assist you more easily should you make a warranty claim.

Before you register please make a note of your caravan's 17 digit VIN number and you 3 digit Registration Security Number.

The VIN number, beginning SGL, can be found on the windows. The Registration Security Number can be found on the Model Label located inside your fridge or oven. The Model Label has a Serial Number or SER.NO and the last 3 digits of this number will form your Registration Security Number.

Please note that your oven and fridge will have different Serial Numbers to each other, but you can use the last three digits from either one to register your van.

Once your detail have been submitted you will be sent an email confirmation that you details and the above numbers have been successfully received.

Additional equipment

If additional equipment (other than those on the optional list) is to be fitted you should check with your dealer beforehand. The warranty may be invalidated.

Vermin

Vermin can gain access via the smallest of holes. Lunar fit grills and grommets to prevent this but the nature of some caravan storage means it can happen with upsetting results. We advise setting a trap and/or poison and regular inspection

Vermin damage is not covered by warranty.



GENERAL DATA

CRiS Registration and VIN Chip

Caravan Registration

This caravan has been security marked and recorded under the Caravan Registration and Identification Scheme that is recognised by the Caravan Industry.

Shortly after purchasing this caravan you should receive your Touring Caravan Registration Document. It will be sent by post to your home address.

Your Touring Caravan Registration Document will include a 17 character VIN (Vehicle Identification Number) shown in the top right hand corner. This 17 character will be permanently marked onto the caravan chassis.

To protect yourself and your touring caravan, never leave the Registration Document in the caravan. For security reasons keep it in a safe place.

If you sell the caravan please follow the instructions on the Touring Caravan Registration Document.

If you do not receive a Touring Caravan Registration Document, lose it, or any of the details recorded are incorrect, please contact: CRiS, Avonbridge House, Bath Road, Chippenham, Wiltshire, SN15 2BB or Tel: 0203 282 1000.

VIN Chip Caravan Identification

The caravan's unique 17 character VIN will be incorporated into VIN Chip tamper evident labels; the master VIN Chip label is situated on the front near side window to aid police checking, another in the gas locker and a maximum of 10 placed on the inside of all windows (with the exception of opaque windows).

Three electronic RFID chips containing the individual identity of your caravan are concealed within the caravan and can only be read by using a specially programmed RFID scanner.

Your local police can obtain the use of a CRiS VIN Chip scanner by contacting CRiS on Tel: 0203 282 1000.



CARAVAN WINTERIZATION GUIDE

If the caravan is to be stored for any length of time, the following procedure is advisable:

1. Location

If possible avoid siting the caravan beneath trees or near dilapidated buildings, where strong winds may dislodge branches or slates that can damage the caravan. In exposed conditions ground anchors may be advisable. Be wary of low lying areas that may be prone to flooding.

2. Covers

Large polythene or tarpaulin sheets should not, in the opinion of most experts, be used to 'seal' the caravan against the elements. Condensation and mould growth may be encouraged and any flapping material or guy ropes could scratch acrylic windows.

If you feel a cover is absolutely necessary because of where the caravan is parked, purchase one that is made of "breathable" material.

3. Ventilation

Caravan vents should be left uncovered to provide adequate air circulation inside the caravan; however if in an exposed or salty location the vents on the side of the prevailing wind and/or the 'fridge vent may be closed off for the winter. If you have

regular access to the caravan, you could place some moisture absorbing crystals in cupboard corners to reduce the risk of condensation, but these will require fairly frequent changing.

4. Interior

To prevent possible mould growth over the winter, clean and vacuum carpets, curtains and upholstery and if possible remove the soft furnishings and store in a warm, dry place (eg attic). If not possible to remove the cushions, store on edge away from the caravan walls, allowing air to circulate around them and cover with an old sheet to prevent fading in the sunlight.

Walls and ceilings should be wiped over with a mild anti-bacterial solution (eg Dettol) and can be polished afterwards if desired. Cupboards should be emptied, cleaned and vacuumed out. Small doors can be left ajar to assist ventilation, but larger doors should be closed or they may warp.

If the caravan is to be stored outside in direct sunlight the sunroof blind is either to be left in the open position, closed only to a maximum of 2/3 of its overall opening.

The refrigerator should be emptied, cleaned with a solution of bicarbonate of soda or anti-bacterial solution and the door left ajar.

The hob/oven should be thoroughly degreased and cleaned. If using one of the stronger oven-cleaners on the market be sure to allow plenty of ventilation whilst working. If necessary burner jets can be brushed over with a stiff brush, and blockages cleared with a high-pressure air line. Never try to clear blocked jets with a piece of wire which can damage or enlarge jet holes.

Water heaters must be drained and care must be taken to remove any lurking pools of water or frost damage may result. If possible blow air through the heater to push any water droplets through. Leave drain taps and inlets open.

The water pipes can be flushed through with a proprietary sterilising agent and the waste pipes with a stronger disinfectant. Make sure the water pump is drained and remove the water filter. Fresh and waste water containers should be cleaned, drained and stored with caps loose or off. Leave all water inlets and outlets open, but they may be covered with a fine mesh material (eg stocking) to prevent entry of insects etc.

The toilet should be cleaned according to the manufacturer's instructions, using a suitable disinfectant for the holding tank. Rinse all sections thoroughly and store unsealed. Any rubber seals or diaphragms can be lubricated with olive oil to prolong life.



GENERAL DATA

5. Battery

Unless powering an alarm system, the 12v battery should be removed, wiped over, the terminals cleaned and smeared with petroleum jelly. The electrolyte level should be checked and topped up with distilled water if necessary. Trickle charge from the mains until you obtain a reading of 12.6v on a voltmeter or 1.27 on a hydrometer. Store the battery in a cool, dry place and check the state every 6-8 weeks. Top up the charge as required.

Electric clocks, smoke detectors etc, if fitted, should have their internal battery removed. Battery powered burglar alarms may benefit from a new set of batteries for the winter.

6. Awning

The awning should be spread out on dry grass or concrete and brushed with a broom to remove any mud. If the canvas is stained try removing the marks with a stiff brush and plain water. If this fails pure soap flakes can be tried, which will mean re-proofing is necessary afterwards, but never use detergents. If stains are stubborn there are proprietary cleaners such as Fabsil Universal Cleaner, available from caravan accessory shops, or contact Grangers International Tel: 01773 521521. Any mildew spots can be treated with a weak solution of hydrogen peroxide – scrub into the affected area and allow to dry before re-proofing (spot test a

hidden area in case colour is affected). Such severe treatment will weaken the awning material so live with stains if you can! Clear windows can be cleaned with methylated spirits if water doesn't work, but nothing stronger. Examine seams and repair any broken stitching and replace perished rubber tensioners. Give the awning a good shake and pack it when completely dry, trying not to put too many creases in the window. Store in a dry, vermin free area.

Awning poles need little attention other than a wipe down with a damp cloth. Don't oil or grease them as this may get onto the canvas. Pegs can be cleaned and straightened and any badly damaged ones can be replaced ready for the next season.

7. Exterior

Your caravan is constructed through the use of several types of materials, paints and coatings in the course of manufacture. Side walls have strengthening inserts in areas which are painted or coated, such materials vary in their make up and over time react differently in opposing areas to atmospheric, chemical and UV influences.

In some instances this can result in a yellowing or matting of components and finishes to varying degrees. This UV or chemical yellowing in no way compromises the usability or performance of the product

and if desired, in most cases, can be restored by polishing with a compound such as T-Cut (always follow the manufacturers recommended guidelines). The caravan will also benefit with regular thorough cleans with a car wash wax type of shampoo.

Look over the rubber window seals and replace any that look perished. Coat serviceable rubbers with olive oil. If you have a damp meter check around the inside for any trouble spots and re-seal suspect joints. Any major damp penetration problems should be resolved before storage. Minor leaks might be cured using Captain Tolley's Creeping Crack Cure. Major leaks require complete renewal of the sealant; both products should be available from caravan accessory shops.

8. Chassis

The chassis should be brushed off, or if exposed to corrosive elements, eg road salt, thoroughly washed down. Any surface rust can be removed with a wire brush or sandpaper and the chassis and axle tube can be painted with a rust inhibitor, suitable paint (eg Hammerite) or Finnigan's Waxoyl. The coupling and all winding mechanisms should be degreased, examined for wear then re-greased.



9. LPG cylinders

LPG cylinders should be removed and stored in a cool, ventilated location. Some storage compounds will insist they are removed to comply with fire safety regulations. The regulator and/or pipe end can be covered with a stocking or similar to prevent the entry of debris or insects that can block the gas supply.

10. Electrics

13 pin, 12N and 12S plugs should be inspected and cleaned and the pins coated with vaseline. WD40 should not be used as it may 'melt' some plastics on contact. The plugs should be protected from the weather but not fully sealed in polythene which will encourage condensation. Road lights should be checked and any water ingress cured, full inspection and cleaning can be done now or left to the springtime service.

11. Axle stands

Ideally the caravan should be jacked up and supported on axle stands with the wheels clear of the ground. Wheels can be removed if desired and stored in a cool, dark place at normal inflation pressure. Inspect tyres carefully and make a note to renew any suspect ones before using the caravan again. The corner steadies should be

lowered and rested on blocks if they do not reach the ground. The handbrake should be left off and the wheels rotated from time to time to keep the bearings lubricated.

12. Security

Finally remove any valuables and documents from the caravan to make it secure; thieves do not hibernate for the winter!

13. Cleaning

Wash the caravan regularly with mild detergent. Rinse with cold water and leather off. For better protection a similar coloured good quality car wax may be applied. For sealed areas a mild soap is the best way to clean without effecting the sealant. Acid or Alkaline based cleaners or solvents should not be used.

Please note that neither Lunar Caravans Ltd nor The Caravan Club endorse any of the listed products and you should satisfy yourself as to their suitability. As always, check that the installation of an after-market accessory does not invalidate your warranty.

A			
Alarm	116	General Data	138
Arrival on Site	28	Lunar Owner's Club	139
Awning Fixing Points	111	Security	138
B		J	
Blinds	117	Jacking Points	27
Bulb Replacement	138	L	
C		Lighting	115
Caravan Handling	26	M	
Caravan Towing Code	4	Microwave	101
Carbon Monoxide Alarm	49	Mirrors	23
Chassis & Undergear		Motorway Driving	26
General Notes on Maintenance	129	N	
D		Noseweight	6
Distribution of Weight	8	Number Plate	23
E		O	
Electrics	64	Oven	
13 pin wiring diagram	24	Grill	98
230V Mains Electric Equipment		P	
Usage	64	Power Control System	68
Instructions for Electricity Supply	64	Pre-load Checklist	8
F		Pre-tow Checklist	10
Fire Action	48	R	
Fire Extinguisher	49	Road lighting	24
Fire Precautions	48	S	
Flyscreens	117	Security	50
Fuses	78	Datachip Security Card	50
G		Smoke Alarm	48
Gas	59	Speed Limits	26
Gas Bottles	59	Stabiliser, AKS2004	12
Gas Safety Advice	62	Stability	9
Precautions	62	Stabilisers	9
Types of Gas	61	Sterilising	55
		T	
		Toilet	
		Cassette Toilet C-260 CWE	107
		Tyres	22, 130
		General Recommendations	130
		Tyres & Pressures	130
		W	
		Warranty	
		Owner's Warranty	139
		Water System	
		Helpful Hints	58
		Pressure Switch	58
		Setting Up the Water System	57
		Wheel Changing	27
		Wheel Lock	16
		Wheels	
		Torque	22
		Winterization Guide	141



NOTES

Publication Designed and Produced by Preset Graphics Ltd
Tel: 01332 549278. Fax: 01332 549279. E-mail: Presetgraphics@btconnect.com
Ref: 21538 © All Rights Reserved