

CONTENTS

TOWING CODE



PREPARING FOR THE ROAD



ON THE ROAD



FIRE & SAFETY



SERVICES



ELECTRICS



FITTED EQUIPMENT



AL-KO CHASSIS & TYRES



GENERAL DATA



INTRODUCTION

INTRODUCTION

Lunar Caravans welcomes you as you join the ranks of owners of Lunar Caravans. We hope you will enjoy your caravan and this handbook tells you how to look after it so that it may give you years of pleasure and enjoyment.

Remember that it is a vehicle and thus calls for a small amount of regular maintenance.

You are requested to contact your dealer on all enquiries in order to ensure satisfaction. You will only experience delays if you bypass the normal channels.

Your Lunar Caravan has been European Commission Whole Vehicle Type approved via LuxControl and has also been inspected by the National Caravan Council (NCC) to ensure your new caravan is compliant and safe to use.

Your Lunar caravan has been built and approved to EN1645 which applies to a large number of features such as:

- sizes of beds
- escape factor i.e. windows and exterior door
- materials
- design and construction

- insulation is grade 3 classified which is able to achieve an average temperature difference of 35 degrees centigrade between interior and exterior when the exterior is -15 degrees centigrade
- electrical equipment, both 12 volt and 230 volt
- chassis
- undergear
- drawbar
- jockey wheel
- wheels and tyres
- installation of gas
- ventilation
- awnings and channel
- fire notices
- handbook

Touring caravans are designated by their model year which runs from 1 September to 31 August. A new year model can only be registered by CRIS from 1st September onwards.

This caravan has been security marked and recorded under the Caravan Registration and Identifications Scheme that is organised by the Caravan Industry.

Your Touring Caravan Registration Document will include a 17 character V.I.N. (Vehicle Identification Number), which is also chemically etched on eye level windows.

To protect yourself and your touring caravan, never leave the Registration Document in the caravan. For security reasons keep it in a safe place.

Disclaimer: The contents of this Handbook book are as accurate as possible at the time of going to print. Lunar Caravans reserve the right to alter materials and specifications without prior notice.



TOWING CODE

Scope of Code	4
Caravan Terms	4
Weights	4
Towing Vehicle Terms	4
Measurement of Noseweight	6



TOWING CODE

THE CARAVAN TOWING CODE

Industry Payload Standard for UK touring Caravans

This standard has been prepared by the National Caravan Council and formulated with input from Industry Experts. The standard applies to UK specification Touring Caravans and will apply for the NCC certification from 2011 onwards model year Touring Caravans.

From the 2012 model year onwards, the method of calculating the Mass in Running Order (MRO) and user payload figures are in line with European Vehicle Directives and conform to requirements for European Whole Vehicle Type Approval EVVTA, 2007/46/EC (The Framework Directive) and the directives referenced therein.

DEFINITIONS

Maximum Technically Permissible Laden Mass (MTPLM)

The fully laden mass of the caravan in the manufacturer's standard specification which is stated in the manufacturer publications by the manufacturer for tow car matching. This mass takes into account the specific operating conditions including factors such as the strength of the materials, load capacity of the tyres etc, and can be found on a plate affixed to the caravan, usually near the entrance door.

Please note: The MTPLM is the maximum weight that the caravan can be loaded to, this mass must NOT be exceeded. However most models can have the MTPLM upgraded in capacity; this must be approved by Lunar Caravans Ltd via the dealership. Please contact your dealership for further details.

Mass In Running Order (MIRO) or (MRO)

This is the weight of the caravan as it leaves our factory (inclusive of the electrical hook-up cable at 6kg and the winding handle at 1kg) plus the following:

8kg gas bottle allowance.

9kg of water in the water heater.

2kg of water in the toilet holding tank as this is the maximum recommended by Thetford.

The weight of the spare wheel is 17.5kg.

User Payload (UP)

The difference between the MIRO and MTPLM (excluding potential MTPLM upgrade). The user payload allows for items common to all occupants, such as food, cutlery, pots, pans, clothing, footwear, bedding, sports equipment etc. The user payload also includes an allowance for the auxiliary battery.

The UP is calculated by the following formula:

$$10L + 10N + 50.$$

L is the body length of the caravan in meters.

N is the number of berths.

50 is for normal equipment carried in the caravan, a sample list is given below.

TV	3kg
Kettle	0.5kg
Bed linen	6kg
Crockery	5kg
Saucepans	3kg
Wastemaster	6kg
Aquaroll (empty)	5kg
Waste bin	1kg
Cutlery	2kg
Toilet fluid etc	2.5kg
Battery	16kg



Optional Equipment Payload (OEP)

Items made available by the manufacturer over and above the standard specification for the caravan in addition to the user payload.

Personal Effects Payload (PEP)

A mass specified for the items which a user can choose to carry in a caravan and which are not included as an essential habitation equipment or optional equipment.

Optional Item	Additional Weight
---------------	-------------------

R/C Alarm/Awning Light	1 kg
AL-KO Secure wheel locks (per lock)	2 kg
AI-KO ATC Trailer Control	2 kg
Air Conditioning	30 kg
Auto Switch over 40L Under slung water tank	47 kg

Please note: Any options fitted by retailer will reduce the overall payload available to the customer.

REGULATORY AND SAFETY ADVICE

WARNING: UNDER NO CIRCUMSTANCES SHOULD THE MAXIMUM TECHNICALLY PERMISSIBLE LADEN MASS (MTPLM) BE EXCEEDED. PLEASE TAKE CARE TO ENSURE THAT YOU HAVE ALLOWED FOR MASSES OF ALL ITEMS YOU INTEND TO CARRY IN THE CARAVAN e.g. Optional equipment and personal effects such as clothing, food, pets, bicycles, sailboards, sports equipment etc.

THE MASS OF THE CARAVAN IN RUNNING ORDER (MIRO) CONTAINS PROVISION FOR THE MASSES OF LIQUIDS, GAS ETC. PART OF THIS PROVISION CAN ALSO BE UTILIZED AS ADDITIONAL PAYLOAD IF FOR EXAMPLE YOU WISH TO TRAVEL WITH NO GAS CYLINDERS.

THE CARAVAN AND TOWING VEHICLE RATIO

This can be determined by calculation and is equal to:

$$\frac{\text{actual laden weight of caravan}}{\text{kerb weight of towing vehicle}} \times 100\%$$

THE **LAW** REQUIRES THAT CARAVANS & THEIR TOWING VEHICLES & THE LOADS THEY CARRY MUST BE IN SUCH A CONDITION THAT NO DANGER OR NUISANCE IS CAUSED.

(Regulation 100 of the Road and Vehicles [Construction and Use] Regulations 1986).

IMPORTANT NOTICE:

Your caravan has been designed and manufactured for towing behind normal road cars. Additional care should be taken when towing with a 4x4 due to the 'off-road' nature of the suspension. Caravans are not suitable for towing behind commercial vehicles.

POWER TO WEIGHT RATIO:

No hard and fast rules can be stated but, here is a general guide.

- (a) Conventional petrol engines with a capacity up to approximately 1500 cc should be adequate for towing a caravan weighing around 85% of the kerb weight of the towing vehicle.



TOWING CODE

- (b) Above 1500 cc such engines should manage a caravan weighing up to 100% of the kerb weight of the towing vehicle and still give adequate performance.

Note: The towing vehicle manufacturer's limit is, in some cases, less than the kerb weight.

Vehicles with automatic transmission may need an oil cooler to be fitted or the SAE rating of the gearbox oil increased when towing. The advice of the vehicle manufacturer should be sought.

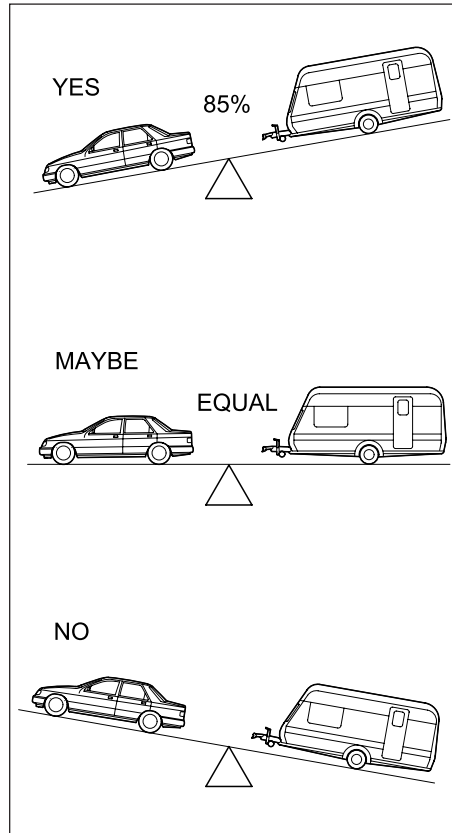

MEASUREMENT OF NOSEWEIGHT

Towing noseweight should be a minimum of 50kg and heavier for twin axle models. This may be measured using a proprietary brand of noseweight indicator. Such equipment is obtainable at your Lunar Caravan Dealer.

Another simple method is to use bathroom scales under the coupling head with a piece of wood fitted between the coupling head and the scales, of such length that the caravan floor is horizontal with the jockey wheel raised.

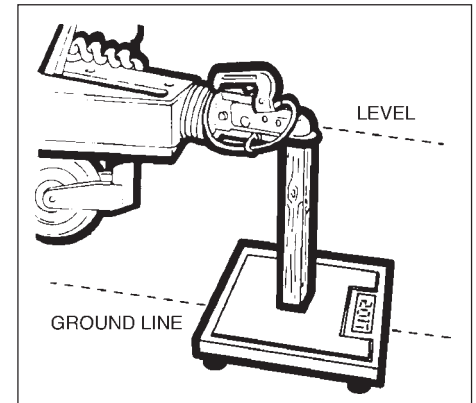



PREPARING FOR THE ROAD

Checklist	8
Loading and Distribution	8
Stability	9
Pre-Tow Checklist	10
Stabiliser	11
Wheel Lock	13
Breakaway Cable	17
Tyres	18



PREPARING FOR THE ROAD

PRE-LOAD CHECKLIST

Caution: Never enter the caravan without first lowering the four corner steadies with the brace provided.

CHECK THAT:

- loose articles are stowed securely. Do not stow tins, bottles or heavy items in overhead lockers prior to towing.
- all lockers and cupboard doors are closed and secured.
- all bunks are secure.
- all rooflights are closed and secured.
- main table is stored in its transit position.
- fridge is on 12v operation and door lock is set.
- all windows are fully closed and latched. Never tow with windows on nightsetting. Leave all curtains and blinds open to aid rear visibility.
- gas cylinders are correctly positioned, secured and turned off.
- battery is secure.
- wheelnuts for tightness.
- tyre pressures and condition of tyres.

LOADING AND DISTRIBUTION OF WEIGHT IN THE CARAVAN

Do not exceed recommended maximum loading for your caravan.

1. Load evenly right to left.
2. Do not load items at the extreme rear

since this can lead to instability due to the 'pendulum effect'.

3. Load remainder to give a suitable noseweight at the towing coupling.
4. Please ensure that your noseweight falls in accordance with the towing vehicle's towball weight limit and doesn't exceed 100kg.
5. Distribute items evenly over the axle and as low as possible to optimize road holding and achieve the best possible braking effect.
6. Do not stow tins, bottles or heavy items in overhead lockers when towing.
7. Loose articles should be stowed securely to avoid movement and possible damage.
8. Ensure that all lockers and cupboard doors are closed and secured.
9. Secure all bunks (if appropriate).
10. Store the main dining table in its transit position.

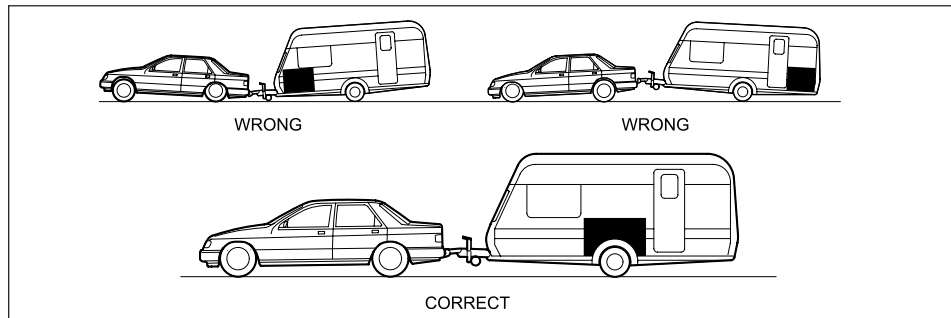
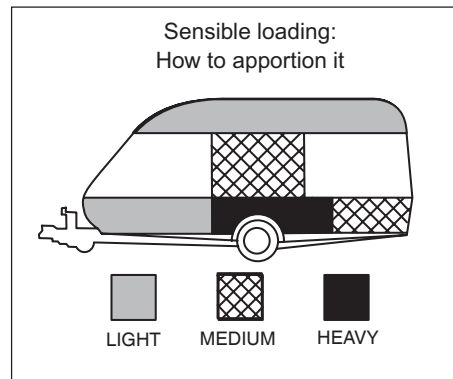

Note: Do not load car boot heavily.



STABILITY

The most common causes of poor stability include:

- (a) Incorrect tyre pressures on car or caravan.
- (b) Worn springs or loose spring fixings on the towing vehicle.
- (c) Towing vehicle shock absorbers too soft.
- (d) Insufficient noseweight.
- (e) Nose of caravan is towing too high.
- (f) Incorrect loading

Stabilisers. There are many proprietary brands of stabiliser available. Your Lunar dealer will be pleased to advise you of the most suitable. They are an aid to stability and should not be considered as a cure for a stability problem.

Note: It is expressly forbidden by the chassis manufacturer for holes to be drilled into the 'A' frame to accommodate a stabiliser bracket. A clamp must be used. Similarly, holes should not be drilled into the coupling head.

Towing vehicle's rear suspension

It is important that the towing vehicle's rear suspension is not deflected excessively by the noseweight on the tow ball. If it is excessive the steering and stability will be affected.

The greater the towing vehicle's tail overhang (the distance between the rear axle and the tow ball) the greater the effect the noseweight will have on the towing vehicle's rear suspension.

After trying out the caravan it may be found that stiffening of the rear suspension is necessary — but note that this may give the towing vehicle a firmer ride when not towing.

There are a number of suspension aids available and advice should be sought on which to use and how to fit.

It is important to ensure that the caravan is towed either level or slightly nose down.

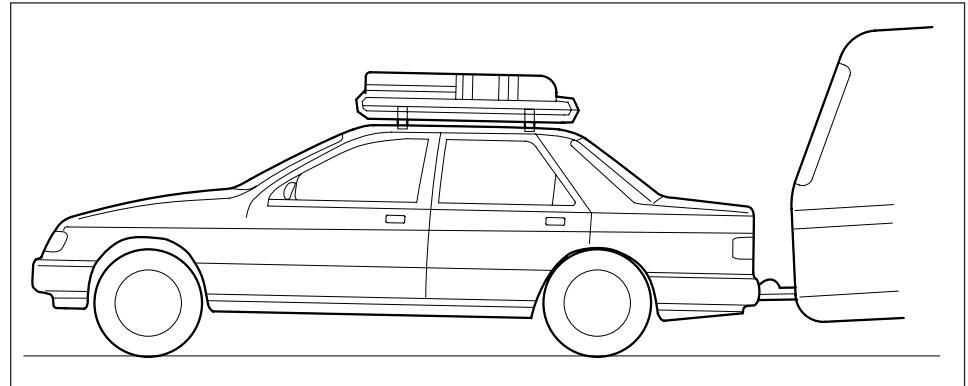

Illustration of excessive deflection of vehicle's rear suspension



PREPARING FOR THE ROAD

PRE-TOW CHECKLIST

1. Check that the hitch is securely coupled onto the towball and connect the breakaway cable. Your hitch height should be around 440mm (17") to the centre of the towball when the towing vehicle and caravan are coupled and laden.
2. The Jockey wheel should be raised and tightly clamped or removed completely if desired.
3. Corner steadies must be wound up fully.
4. Plug in the electrical connection to the car, keeping the cable clear of the road and check the operation of lights.
5. Release the handbrake. "Failure to ensure that the handbrake is completely off, can result in overheating of the brakes and failure of the bearings".
6. Check tyre pressure with cold tyres (see specification). Wheel bolt torque settings should be 88Nm (65lbs/ft) for steel wheels. Alloy wheels should be 115Nm (85lbs/ft).
7. Adjust the tyre pressures of your tow car to the manufacturers recommendations for full loads.
8. Engage the stabiliser, if fitted.
9. Fit towing mirrors to your car.

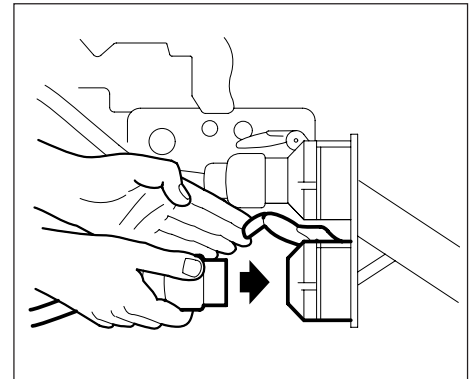
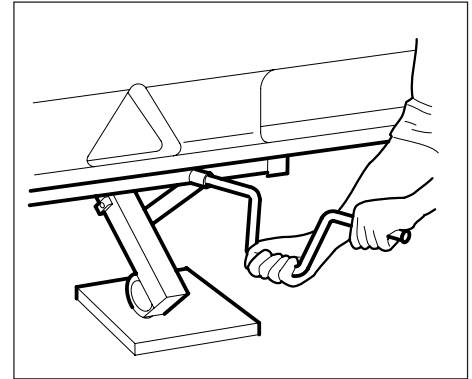
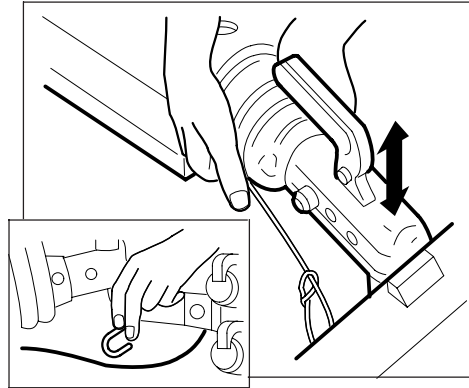



AKS STABILISER (where fitted)

This model of stabiliser has 4 special friction pads, which suppress both snaking and pitching. It is essential that the tow ball is kept completely clean as contaminated pads will reduce its effectiveness.

Operating instructions

- Using the coupling handle, put the AKS on to the towball. Push the black handle down and check the green indicator button is showing (Fig. 1).
- Press the red stabilising lever down. The AKS is now ready for the road (Fig. 2).

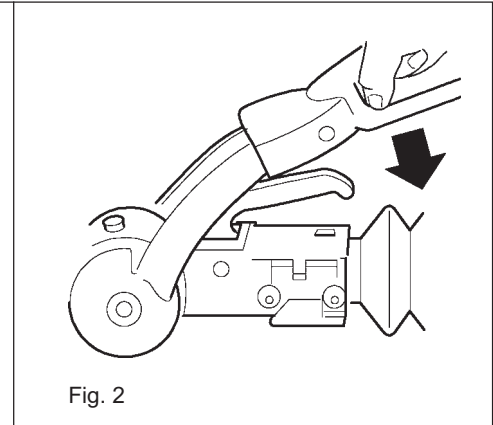
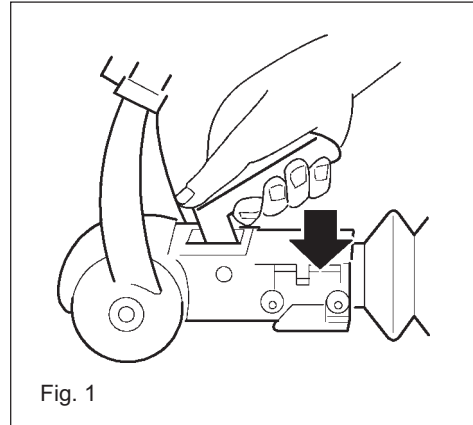

Safety indicators

If the green indicator is visible then you know you have correctly coupled your AKS to your towing vehicle (Fig. 3).

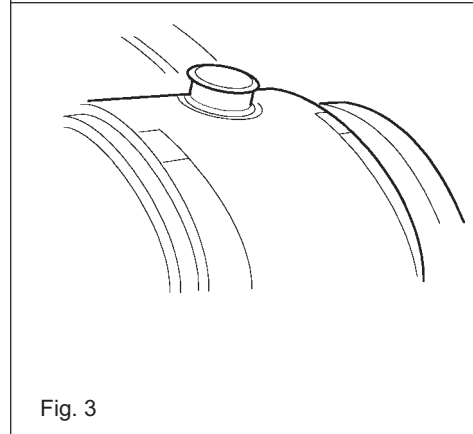

Wear Indicator

For Coupling mechanism and front/rear friction pads. (Fig. 4)

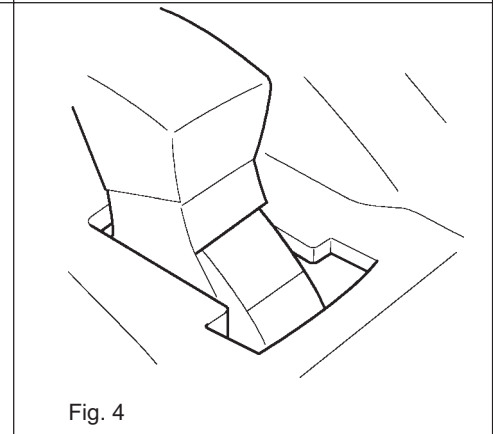



PREPARING FOR THE ROAD

- Wear of the coupling ball and mechanism can be easily monitored. If the green section is visible (when coupled to your towball) then the front/rear friction pads, coupling ball and mechanism are in order.
- If the red lower section obscures the green section then you need to check these parts immediately.

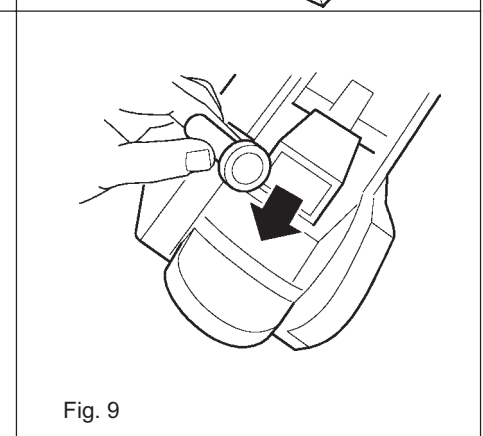
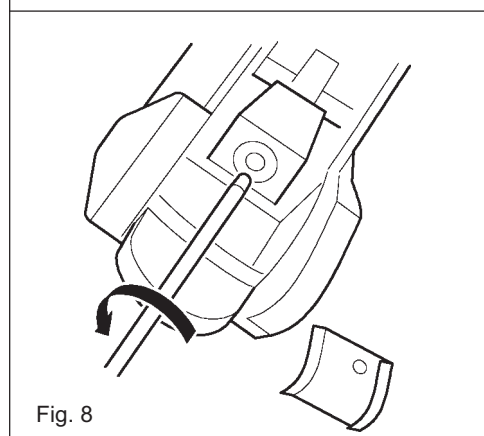
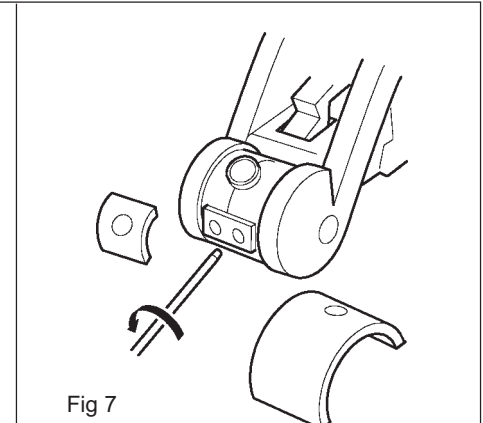
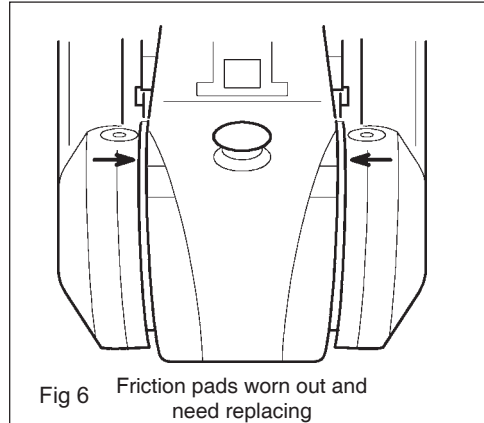
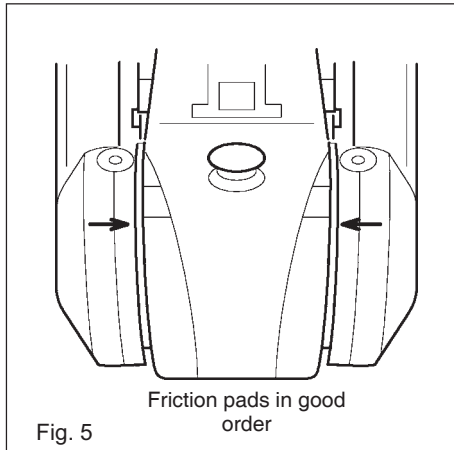



Friction Pads Replacement

- Unscrew the 2 screws which are under the soft dock by using the special torx tool (UK version only). (Fig. 7)
- Remove screw from back plate. (Fig. 8)
- Remove friction pads. (Fig. 9)

Loading Capacity

The AKS can be utilised to tow vehicles up to a gross weight of 3000kg and a maximum nose load of 100kg.

AL-KO SECURE WHEEL LOCK

You must register your key, should you fail to do this you will not be able to order a spare key or obtain lost or stolen keys.

This is how it works:

- On the Al-Ko Secure registration card you will find an exclusive security number.
- Please register your key by telephoning 0870 7576788 or 0044 1926 818500.
- You will be required to provide the chassis number of the caravan.
- You will need to provide us with a password and supply answers to three security questions.
- Make a note of your password and keep it in a safe place.
- Also keep your registration card safe.
- Take your registration card with you when you are travelling with the caravan.
- Always keep your registration card separate from the lock.

Safety Information

- Always secure the caravan against movement (chock the wheels, couple to towing vehicle).
- Never leave Secure parts (key, locking bolt, registration card) in the caravan.
- Always remove Al-Ko Secure before moving the caravan.
- After any attempt at theft has been made on a locked Al-Ko Secure, the caravan must be inspected in an Al-Ko Approved Service Workshop.
- Always keep the key in a safe place.
- Keep the lock set and registration card separate from the keys.
- The lock parts and key do not have a registration number, therefore keep the registration card in a safe place.
- Caravans with twin axles have two locks, keep each lock set in a separate place. The sets are not interchangeable!

Note: Read the operating instructions and act in accordance with them. Keep the operating instructions for general use. Follow the safety instructions as well as the warning information.



PREPARING FOR THE ROAD

ASSEMBLY

We recommend the use of a side-lift jack for easier fitting of AI-Ko Secure when used on a tandem axle caravan. (Order No. AI-Ko Jack Set 1389235).

- Align the wheel so that the receiver can be seen in the centre of the rim opening. DO NOT use the rim opening in which the tyre valve is fitted. (Fig. 1)
- Unscrew the plastic cap from the receiver and store in the tool kit box. (When AI-Ko Secure is not in use, always screw the plastic cap in place). (Fig. 2)
- Insert the locking bolt into the rim specific insert. (Fig. 3)
- Insert the locking bolt socket key. (Fig. 4)
- Line up the locking bolts and assembly with the receiver. (Fig. 5)
- Tighten the locking bolt socket using the wheel spanner provided (or torque wrench as shown) to wheel torque. (Fig. 6)
- Remove the locking bolt socket key. (Fig. 7)
- Insert barrel lock. (Fig. 8)
- Hold the lock fast and lock. (Fig. 9)
- The AI-Ko Secure is now fitted. (Fig. 10)

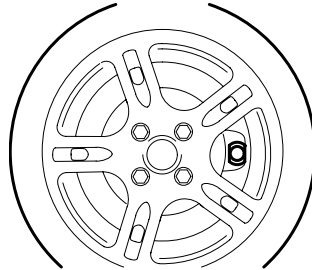

Fig. 1

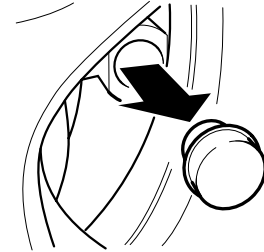

Fig. 2

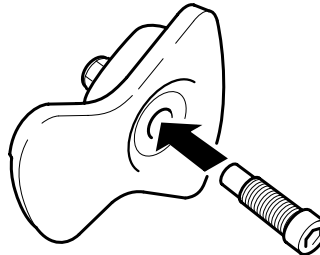

Fig. 3

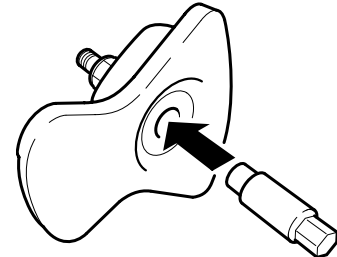

Fig. 4

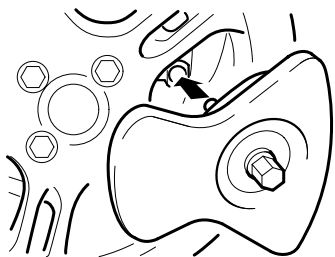

Fig. 5

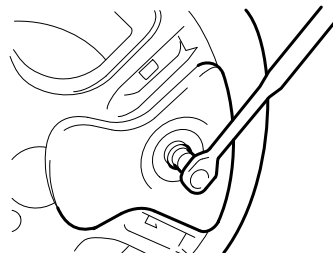

Fig. 6

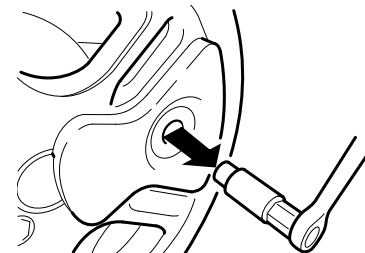

Fig. 7

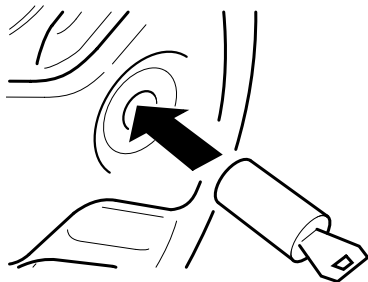

Fig. 8



Fig. 9

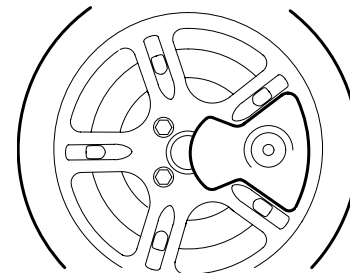

Fig. 10



PREPARING FOR THE ROAD

TWIN AXLE CARAVANS

Fit the front lock first by aligning the wheel so the receiver can be seen in the centre of the rim opening. Chock front wheel and opposite wheel. Jack the caravan (preferably using the Al-Ko side lift jack) until the rear wheel is clear of the ground. Fit the second lock by aligning the wheel as described previously

Note: Lost components phone 0044121 5050400.

In the event of attempted theft report to police and your insurance company.



SECONDARY BRAKING CABLE (Break away device)

Purpose - To apply a trailer's brakes if it becomes separated from its towing vehicle. Having done this, the cable assembly is designed to part, allowing the trailer to come to a halt away from the towing vehicle.

Construction - A thin steel cable, possibly plastic coated, and fitted with a means of attachment for connection to the towing vehicle.

Operation - In the event of the main coupling of the trailer separating from the towing vehicle, the cable should be able to pull tight, without any hindrance, engaging the trailer's brakes.

NOTE: The breakaway cable should never become taut during normal use.

Correct procedure for use:

- Regularly check the cable and clip for damage. If in doubt, contact your dealer or service agent.
- Make sure the cable runs as straight as possible and goes through a cable guide underneath the trailer coupling.
- Determine whether or not the towbar has a designated attachment point (i.e. a part specifically designated by its manufacturer for a breakaway cable).

Where a designated attachment point is provided on the towbar:

Either:

- Pass the cable through the attachment point and clip it back on itself (Fig 1).

Or:

Where no designated attachment point has been provided on the towbar:

Fixed ball - Loop the cable around the neck of the towball. If you fit the cable like this, use a single loop only. (See Figs. 2 and 3).

Detachable ball - You must seek guidance on procedure from the towbar manufacturer or supplier.

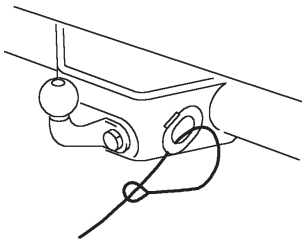

Fig 1

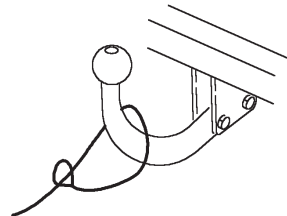

Fig 2

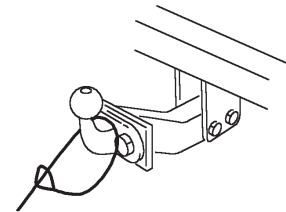

Fig 3



PREPARING FOR THE ROAD

Other means of attachment:

In some instances it may be possible to attach the cable assembly:

Either:

- a) to a permanent part of the towbar structure, as long as this meets the approval of the towbar manufacturer/supplier,

Or:

- b) to an accessory sold for the specific purpose of breakaway cable attachment.

When the breakaway cable is attached, check to ensure:

- a) that the cable cannot snag in use on the trailer coupling head, jockey wheel, or any accessory, e.g. a stabiliser, bumper shield, cycle carrier, etc.
- b) that there is sufficient slack in the cable to allow the towing vehicle and trailer to articulate fully without the cable ever becoming taut and applying the brakes.

NOTE: For peace of mind you might wish to check the state of the cable by positioning the trailer and towing vehicle at extreme angles before setting off.

- c) that it is not so slack that it can drag on the ground. If left loose, the cable may

scrape along the ground and be weakened so that it subsequently fails to do its job. The cable may also be caught on an obstacle when in motion thus engaging the trailer brakes prematurely.

Having followed this advice, should you feel that a satisfactory coupling arrangement cannot be achieved, consult your trailer or towbar supplier or service agent.

- It is a legal requirement that the secondary break away cable is used when towing.

WHEELS

Check wheel nut torques regularly and particularly before a long trip for extra safety.

This service is available at all tyre service depots (inform them of the torque settings)

- The torque settings are:

ALLOY WHEELS	115Nm
STEEL WHEELS	88Nm
- Check wheel/tyres for signs of deterioration or damage.

WARNING: After a wheel has been refitted, always recheck the torque after 20-30 miles use or 20-30 minutes travelling. Even if properly torqued up, it is occasionally possible for fixings to loosen should the wheel "bed in" on the hub.

TYRES

All tyres used on Lunar caravans, when inflated to the pressures recommended, are adequate for speeds up to 130 kph at the maximum specified laden weight of all models.

Note: Maximum permitted speed in the U.K. is 60 mph and in the interests of road safety speeds above this are not recommended.

Tyre tread

A caravan is subject to the same criteria applied to car tyres, namely; a minimum of 1.6 mm tread pattern depth throughout.

Tyre pressures

Caravan and towing vehicle tyres must be at the pressures recommended for towing or heavy loading. The pressures can be found in the towing vehicle handbook and under the caravan specification in the service handbook.

Note: Pressures should only be checked when the tyres are cold, not after a journey or if the vehicle has been standing in the sun.

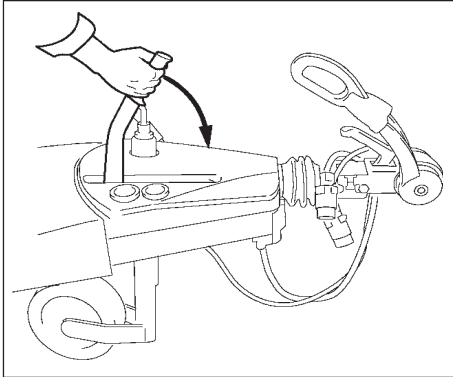

To release the handbrake, push it forward and down using your body weight.

Note: “Failure to ensure that the caravan handbrake is completely off, can result in overheating of the brakes and failure of the bearings”.

Ground Clearance

Care has to be taken to prevent grounding of the caravan when traversing ramps and ground obstacles. If necessary ground clearance can be increased by removing the jockey wheel when travelling.

Number Plate

A trailer must carry a rear number plate bearing the number of the towing vehicle and be illuminated at night. The number plate should conform to the same size and colour regulations as for cars. A reflective black and yellow plate may be used on a trailer towed by a vehicle with non-reflective plates and vice-versa.

Manoeuvring

When pushing or pulling the caravan always use the grab handles correctly, do not snatch them and never push body panels, metal or glass reinforced plastics, as this can cause serious damage to the bodywork or mastic seals.

Mirrors

The driver of the towing vehicle must have an adequate view of the rear.

If there is no rear view through the caravan it is essential that additional exterior towing mirrors are fitted.

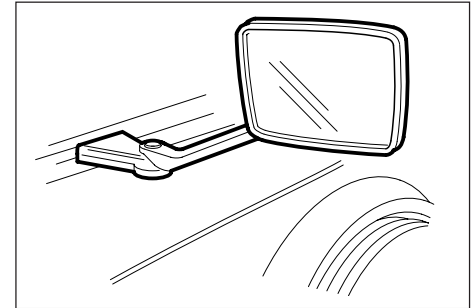

Caution: Any rear view mirror must not project more than 200mm outside:

- the width of the caravan when being towed.
- the width of the towing vehicle when driven solo.

Note: Any rear view mirror fitted shall be ‘e’ marked and cover the field of view as stipulated by type approved requirements (Regulation 33 of the Road Vehicles [Construction and Use] Regulation 1986).



PREPARING FOR THE ROAD

Road lighting

For your information the wiring diagram of the 13 pin connector is shown. These should be checked regularly and if in any doubt a qualified electrician consulted.

Passengers

Passengers are forbidden to ride in a caravan with the exception of authorized test personnel.

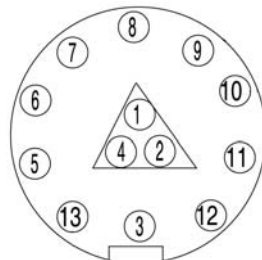

PIN No	COLOUR	DESCRIPTION
1	YELLOW	LEFT IND
2	BLUE	FOG
3	WHITE	NEG FOR ROAD LIGHTS
4	GREEN	RIGHT IND
5	BROWN	RIGHT SIDE LIGHTS
6	RED	STOP
7	BLACK	LEFT SIDE LIGHTS
8	ORANGE	REVERSE
9	BLUE/BROWN	CAR +VE
10	RED/BROWN	FRIDGE +VE
11	GREEN/WHITE	FRIDGE -VE
12	EMPTY	
13	BLUE/WHITE	CAR -VE

13 pin plug wiring diagram



ON THE ROAD

- Speed Limits 22
- Pulling Off 22
- Caravan Handling 22
- Motorway Driving 22
- Reversing 22
- Changing a Wheel 23
- Jacking Points 23
- Stopping on a Hill 24
- Arrival on Site 24



ON THE ROAD

SPEED LIMITS

Normal road towing: 50mph

Motorways (including dual carriageways):
60mph

PULLING OFF

Let the clutch in smoothly.

Allow more engine speed to produce the power to move the additional weight of the caravan.

Avoid wear and tear on clutch and transmission by taking extra care.

Change gears smoothly.

Try not to jerk the clutch.

CARAVAN HANDLING

Allow for caravan being wider than car.

Do not bump kerb with caravan wheels.

When passing other vehicles allow more than the normal clearance for driving solo.

Allow longer to get up speed to pass.

Allow for the vehicle being twice its normal length.

Do not suddenly swing out.

Carry out all manoeuvres as smoothly as possible.

Use nearside wing mirror to check caravan has cleared when overtaking.

Never let a 'tail' of traffic build up behind you. Always pull in to let others past.

MOTORWAY DRIVING

1. Caravans may not be towed in the outside lane of a three or four lane motorway. (Reg. 12(2) of the Motorway Traffic [England and Wales] Regulations 1982).
2. Reduce Speed:
 - i) In high or cross winds.
 - ii) Downhill.
 - iii) In poor visibility
3. High sided vehicles cause air buffeting so extra care must be taken when passing or being passed. As much space as possible should be given.

REVERSING

Proficiency at reversing can only be achieved with practice and should be first attempted in a large open area.

Your caravan is fitted with an automatic reversing mechanism which allows you to reverse without the need to make any adjustments. **After reversing, the caravan should be drawn forward at least 1 metre to restore the brake shoes to their normal position before applying the hand brake.**

Note: Reversing uphill will be difficult if either wheel brake or brake linkage is overadjusted. You need to ensure that the brakes have been disengaged before reversing uphill.

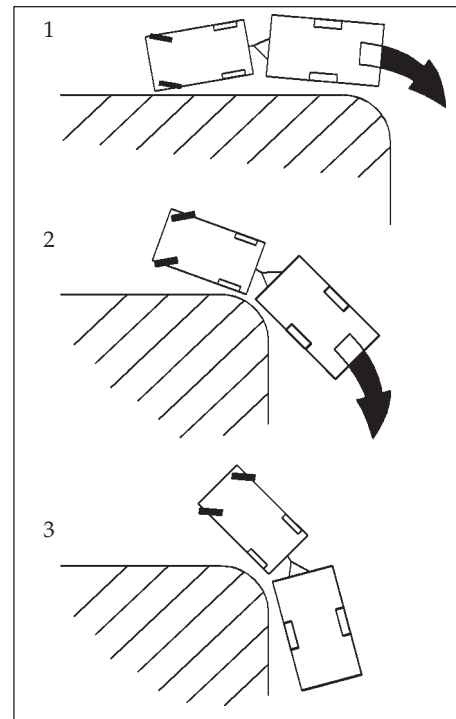

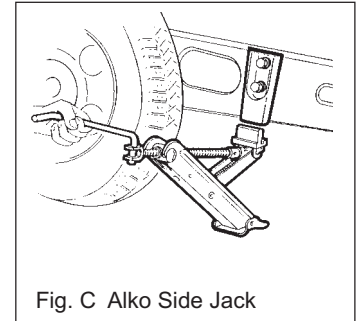
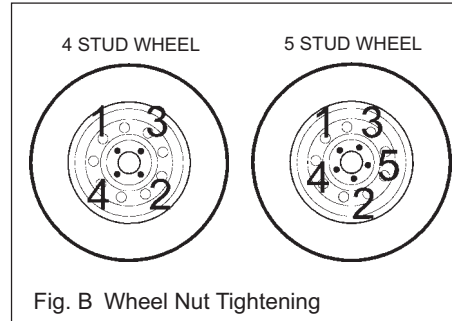
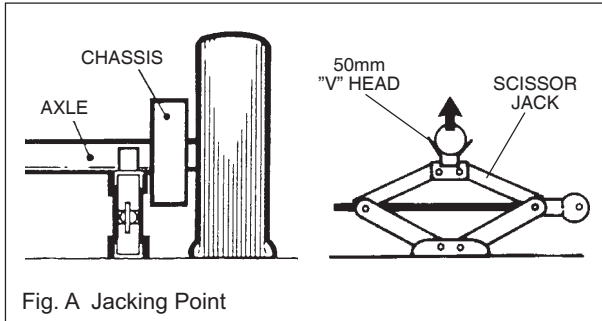

CHANGING A WHEEL

1. Leave caravan hitched to towing vehicle and ensure handbrake is applied.
2. Lower corner steadies (as safety measure) on the side that the wheel is being changed to stabilise the caravan.
3. Use wheel brace to slacken off wheel nuts on the wheel to be changed.
4. Position jack under the axle at the appropriate jacking point (see fig. A).
5. Jack up the caravan until the wheel for removal is just off the ground.
6. Remove the wheel bolts, wheel trims and remove the wheel.
7. Fit spare wheel and reverse the above procedure.
8. When replacing the wheels you should tighten the nuts in rotation diagonally. Tighten all nuts equally, according to Fig. B, to 88Nm (65 lb/ft)

for steel wheels and 115Nm (85lbs/ft) for alloy wheels using a torque wrench or have checked as soon as possible.

Note: When changing a wheel ensure:

- a) that the correct wheel fixings are used.
- b) that there are clean, dry mating surfaces and clean, dry bolt/nut area.

NB: Special nuts are supplied with alloy wheels and these can be used where a steel wheel is used as a temporary spare.

If replacing an alloy wheel nut, a nut to the following reference should be purchased: M12 x 1.5 pitch, 26mm thread, 10.9 grade, 60 degree conical fixing, 19mm hexagon bolt head.

IMPORTANT

When a wheel has been removed and replaced the torque of the wheel nuts should be re-checked after approximately 15 miles of running.

JACKING POINTS

It is recommended that the jack is located in the correct position i.e. on the axle tube inside the chassis member (Fig. A). The reinforced axle mounting plate can be used as an alternative but the chassis- member itself **MUST NEVER** be used as a jacking point.

Alko Side Jack

The Alko chassis is provided with the facility to fit an Alko side jack which can be fitted as an optional extra (Fig. C).



STOPPING ON A HILL

Pulling off again can sometimes present a problem. The easy solution is:

- (i) Carry a good sized wedge shaped piece of wood with a rope or light chain attached.
- (ii) Attach the other end of the rope to the nearside rear grab handle.
- (iii) Place the wood behind the nearside caravan wheel.
- (iv) Carefully reverse the car slightly back down the hill, the caravan will stop against the wedge and turn.
- (v) Drive forward since this attempt to move up the hill will now not involve pulling the full weight of the caravan until the car has gained some traction.

Ramps

Take care to prevent fouling when traversing ramps or other ground obstacles.

ARRIVAL ON SITE

Note: Check and observe site regulations.

1. Selecting a pitch.

Do not pitch in such a position that your outfit will obstruct others coming in.

Try to choose an area which is dry, reasonably level and preferably with a hard base.

If you have no alternative but to pitch on a slope ensure that, for when you leave, you are facing down the slope.

It is good practice to chock the wheels of the caravan when parked on a slope even though the caravan brakes are applied.

2. Siting/Unhitching

When you arrive at your site and have been allotted a pitch:

Manoeuvre your caravan onto your pitch (if you have reversed read the notes on page 20), apply the handbrake, remove the brake safety cable, unplug the 13-pin plug and store these in the sockets provided on the 'A' frame cover.

Unclamp and lower the jockey wheel to the ground. Re-clamp the jockey wheel after first unscrewing slightly.

Free the coupling by winding up the coupling head until it is clear of the 50mm ball. Replace the tow ball cover and then park your car.

3. Levelling the caravan

Levelling must be carried out in both directions in order for the refrigerator and other equipment to function correctly.

The positioning of the jockey wheel can be used to help level the caravan.

Lower the corner steadies until they are in firm contact with the ground. DO NOT use the steadies as a jack they are only a means of stabilising the caravan.

Levelling pads or boards should be used under the steadies where the ground is soft or uneven. Stepped levelling boards can easily be constructed (Fig. D).

In extreme cases where it is necessary to raise a wheel off the ground for levelling purposes, further adequate support should be applied so that the steadies do not take any undue strain.

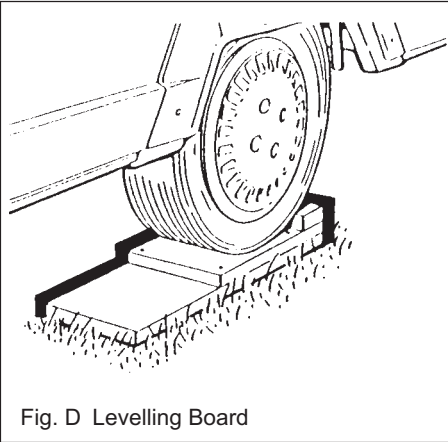

Fig. D Levelling Board

Exterior Door

To prevent distortion of the body, the caravan must be always correctly sited and levelled. Failure to site the caravan correctly may prevent the exterior door from closing properly.

Attention: Always disconnect the electrical connector between the towing vehicle and the caravan before connecting an LV supply to the caravan and before charging the caravan battery by any other means.



**FIRE
&
SAFETY**

- In Case of Fire 28
- Smoke Alarm 28
- Carbon Monoxide Alarm 29
- Fire Extinguisher 29
- Children 29
- Ventilation 30
- Security 30
- Theft 30



FIRE & SAFETY

FIRE ACTION

1. **GET EVERYONE OUT**
2. **TURN OFF GAS VALVE**
3. **RAISE THE ALARM AND CALL THE FIRE BRIGADE**
4. **DISCONNECT THE MAINS ELECTRICITY SUPPLY**
5. **TACKLE THE FIRE IF SAFE TO DO SO**
6. **MAKE YOURSELF FAMILIAR WITH THE INSTRUCTIONS ON YOUR FIRE EXTINGUISHER AND THE FIRE PRECAUTION ARRANGEMENTS ON THE SITE**
7. **CHECK FIRE EXTINGUISHERS REGULARLY**
8. **CHECK GAS PIPING AND MAINS ELECTRIC WIRING ANNUALLY**

If you suspect a gas leak - never use a naked flame to search - always use soapy liquid or - better still - call your caravan dealer.

Important

With any extinguisher, never use it on a pan of fat - this is very dangerous - always use a fire blanket.

To tackle a pan fire: First of all, if possible try to turn off the gas. Make sure you are aware of the position of the gas isolating taps - usually placed in the sink unit cupboard.

Never throw a flaming pan outside, keep your hands away from the flames and smother the flame.

Try to remain calm.

Do not throw the blanket on the fire but place over the pan paying particular attention to the handle.

Fire Precautions

Make sure you are aware of the operation and location of escape windows and doors.

It is advisable to carry a fire extinguisher (a dry powder is recommended) positioned as near to the exterior door as possible.

A fire blanket approved to BS 6575 is also advisable positioned as near to the cooking area as possible.

Check the fire regulations on arrival at sites. Do not leave pans on the stove unattended. Do not leave matches within easy reach of small children.

Never leave small children alone in the caravan.

Do not smoke in bed.

Do not block up ventilators.

SMOKE ALARM

The Code of Practice requires that a smoke alarm is fitted in your caravan. Every new

manufactured caravan has a smoke alarm fitted as standard equipment.

Connecting the battery

Your alarm requires one 9 volt battery to power the smoke detector portion of the unit. Under normal use, the battery powering the smoke detector should last approximately one year. See label inside smoke alarm lid for suitable batteries.

With a pencil, write the date of battery installation on the inside of the cover to remind you when to replace the battery.

Lift battery from battery holder and snap battery connectors to battery. They fit together only one way.

Gently push battery into battery holder.

To close the cover match up snap-in hinges and gently press together until base and cover snap together.

IMPORTANT

When the battery is first connected the alarm may sound for 2-3 seconds.

THIS IS NORMAL.

It means the battery is connected correctly.

Replacing the battery

Test the alarm for correct operation using the test button whenever the battery is replaced.



When battery power is low and replacement is necessary, the alarm will 'beep' about once per minute for at least 30 days. The battery must then be replaced. Replace battery if the alarm does not sound when the test button is pressed. For maximum reliability, replace battery at least once a year.

Testing the Smoke Alarm

It is recommended that you test the smoke alarm once a week to be sure the unit is working. It will also help you and your family to become familiar with the sound of the alarm.

When you press the test button it simulates the effect of smoke during a real fire. So, there is no need to test the alarm with smoke.

Press and hold the test button until the alarm sounds (it may take up to 10 seconds). The alarm will stop sounding shortly after the button is released.

Cleaning the Smoke Alarm

Clean the smoke alarm regularly. Use a soft bristle brush or the brush attachment of your vacuum cleaner to remove dust from the sides and cover slots where the smoke enters. Keep cover closed while cleaning. Do not vacuum or brush inside the smoke alarm. To clean the cover, remove it completely and use only mild soap and water. Dry cover thoroughly before replacing it.

Warning: Do not paint the Smoke Alarm.

Other than the maintenance and cleaning described above, no other customer servicing of this product is required.

CARBON MONOXIDE ALARM

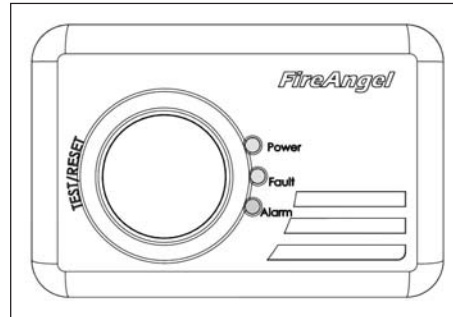

Your carbon monoxide alarm is located on the underside of the offside or nearside locker. Under normal operating conditions the power pack will last for the lifetime of the product (7 years). Batteries for this product are non replaceable.

It is recommended that the alarm is tested weekly by pressing the test/reset button.

LED Indicators

Power. In normal operation the LED will regularly flash green.

Fault. If a fault is found in the sensor and circuitry or the power pack becomes low then the detector will emit a single chirp once per minute and the fault LED will flash yellow once per minute for 30 days.

Alarm. When sufficient carbon monoxide is detected a loud audible signal will be emitted and the alarm LED will flash red once every second. When alarm is tested the LED will illuminate red.

FIRE EXTINGUISHER

It is recommended that a 1kg (2lb) minimum capacity dry powder fire extinguisher be carried inside your caravan at all times. (NCC recommend types marked 5A34B).

When using a dry powder extinguisher it is suggested that the caravan be evacuated until the powder has settled, to avoid inhalation.

A fat pan fire should not have a fire extinguisher aimed at it. It should be smothered with a fire blanket.

Children

Do not leave children alone in the caravan in any event. Keep potentially dangerous items out of reach, as at home e.g. matches, drugs etc.



FIRE & SAFETY

Bunks

Where fitted, the foldaway bunk has been tested to 70kg (11 stones) and has a recommended limit of 57kgs (9 stones). Safety features are included but care should always be taken, particularly if the child is under 3 years of age. Bunks are not suitable for children under 6 years old without supervision.

Solid (fixed) bunks have a recommended limit of 75kg (12 stones).

Ventilation

All caravans comply with British Standards EN1645. The ventilation points on your caravan are fixed points of ventilation which are stated by the British Standards.

Ventilation is provided at floor and ceiling level and care should be taken to ensure these remain clear of debris by regular cleaning.

Under no circumstances must these vents be blocked or obstructed.

It is advised that fixed ventilation points are checked and cleaned (if necessary) on a regular basis.

Additional night time ventilation is obtained by releasing the window catches and placing them in the second groove on the frame catch.

You must maintain adequate spacing of combustible materials from sources of heat (eg heater)

Do not use independent gas appliances inside the caravan.

We advise that the user instructions for the fitted appliances are studied in addition to the information in this handbook.

Petrol/Diesel Fumes

The fitting of a tail pipe to your car exhaust will reduce the possibility of fumes entering your caravan through the front fixed ventilation points.

SECURITY

Caravan theft

The theft of a caravan can occur in the most unlikely circumstances; from a motorway service area, even from an owner's driveway.

Secure all windows and doors when your caravan is unoccupied even if only for a short length of time.

Vehicle Identification Number (V.I.N.)

Record your caravan V.I.N. which can be found on **any of the eye level windows.**

Additional security

Consider fitting any device which might deter or prevent intrusion by thieves.

A hitch lock cover helps to prevent towing of the caravan.

A wheel lock prevents towing of the caravan and removal of the wheel.

Customers are advised to identify their caravan with a method for subsequent identification if other forms of identification have been altered or removed.

Datachip Security Card

Each model has a datachip security card concealed within the body of the caravan, showing the VIN.



SERVICES

Water	32
Gas	39
Electricity	44



SERVICES

WATER SYSTEM - DELTA MODELS

An underfloor water tank with an approximate capacity of 40 litres of fresh water is fitted as standard equipment on the Delta models only. Water levels are displayed by a series of LED's on the control panel. The tank has its own in-built pump and filling of the tank via the external pump supplied, which is operated by a switch on the control panel.

Full switching operation for the pumps can be found under Delta control panel.

Due to weight and stability we recommend that the tank is drained prior to towing.

DO NOT ALLOW ANY OF THE PUMPS TO BE ACTIVATED WHEN NO WATER IS PRESENT AS THIS WILL DAMAGE THE PUMP.

The tank is fitted with an overflow and a drain cock.

Do not use bleach or detergents for cleaning the system but rather a formulation from your chemists normally used by home brewers.

WATER SYSTEM WITH UNDERFLOOR WATER TANK - DELTA MODELS

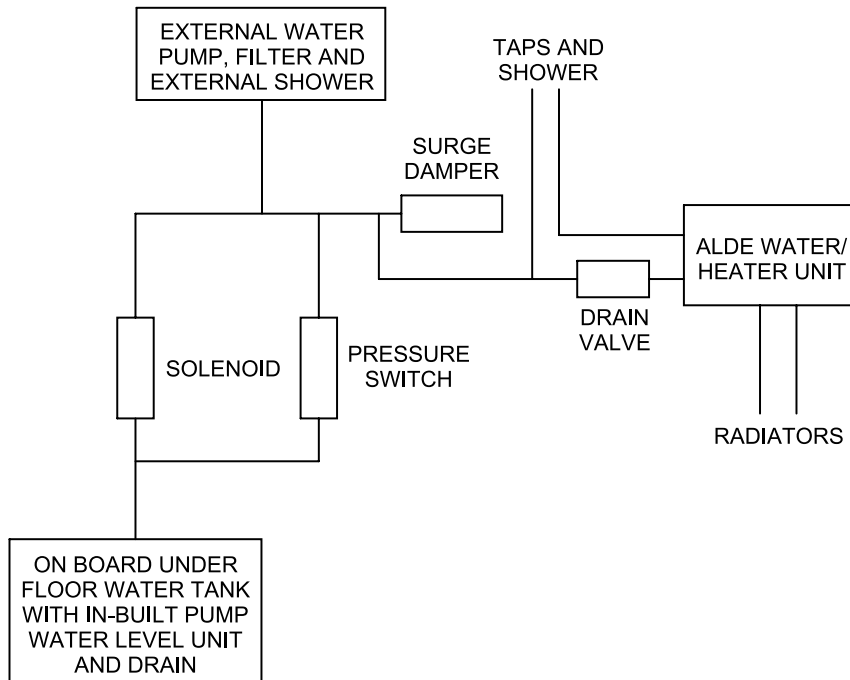



STANDARD WATER SYSTEM

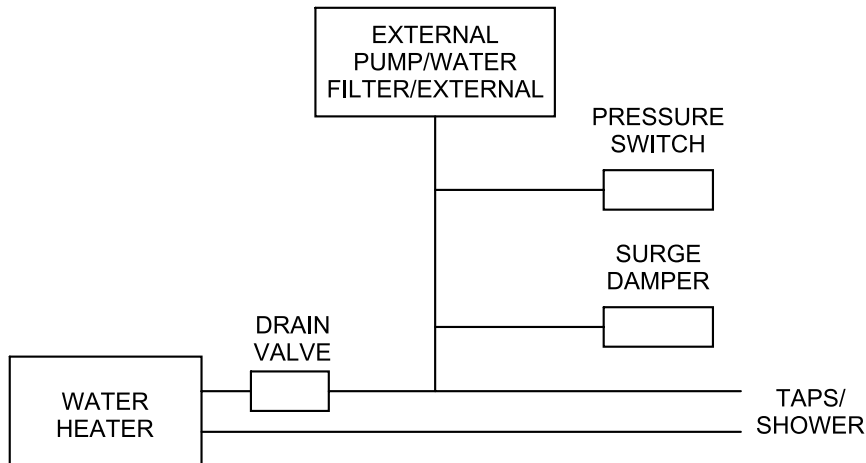

Whale Surge Damper

The surge damper prevents water hammer and also reduces switch hunting on and off.

The surge damper is a completely sealed unit and requires no servicing, however, as with Whale water systems, the complete system should be drained in the winter.

The Filter

The filter attaches directly to the pump and incorporates a non- return valve designed to prevent dirt and grit from entering the pump valves as this will cause pump failure. The filter is fitted during installation to protect the pump.

Pressure Switch

The pressure switch is operated by the opening and closing of the taps/shower. When a tap is opened the pressure in the system is altered which activates the pressure switch supplying power to the selected pump.

Solenoid

The solenoid is an electrically operated valve controlling the water flow from internal and external pumps.

Maintenance

Poor pump performance may be an indication that the filter has become blocked



SERVICES

by debris. The filter is easily removed for inspection and cleaning:

- Remove circlip and unscrew filter from pump.
- Pull two halves of filter apart to expose the strainer mesh.
- Remove any debris and replace strainer mesh in position.
- Ensure the rubber seal is correctly seated in the groove on the outlet side of the strainer before pushing the two halves firmly together.
- Attach to the pump and replace the circlip.
- See arrow on pump housing for flow direction.

Care of your Submersible Pump

Care should be taken to ensure that the pump is not allowed to run dry for appreciable periods. Whilst the design will allow some dry running, such as when the tank requires refilling, the pump life will be appreciably lengthened if care is taken to minimise dry running.

Aquaflow Caravan Filler

There is a special filler fitted for use with the Submersible Pump which not only provides a recessed, locking filler cap for water input, but also a polarised power take-off point complete with input plug. This is part of the original equipment for Delta models only.

The Water System for Delta Models

A submersible pump is used for pumping water from an external container into the inboard tank of the caravan.

To Operate The System

First ensure that the drain tap on the inboard tank is closed. Place the pump inside your filled container. Place the hose into the filler cap on the side of the caravan. Plug in the 12 volt plug into the socket on the filler cap. When the water container is empty unplug the 12 volt - do not allow the pump to run dry.

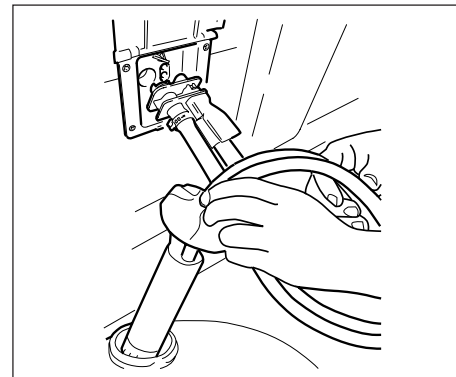

WATER PUMP

The separate plug-in pump assembly consists of a Crystal Maxi pump, hose and plug. The plug provides connection of both water supply to the caravan and 12V dc electric power to the pump. A dust cover is fitted to the connecting dual hose to prevent contaminants falling into the water container.

The Crystal Maxi pump is a completely sealed unit designed for intermittent use. It is NOT self-priming and therefore to ensure proper performance, the pump **MUST ALWAYS** be fully submersed in water **BEFORE** plugging into the wall socket.



Initial connection to fresh water supply

1. Fill the fresh water container and place it alongside the wall socket located in the offside external wall of the caravan.
2. Ensure the pump isolator switch at the control panel inside the caravan is switched off.
3. Open the 'hot' kitchen tap. Ensure all other taps are closed.
4. Place the pump into the water container outside the caravan, taking care to ensure the pump reaches the bottom of the container.
5. Lift the lid of the wall socket and fit the pump assembly plug into the socket. Ensure it is pressed in fully.
6. Adjust the dust cover to fit over the opening in the water container to keep contaminants out.
7. Switch on the pump isolator switch at the control panel inside the caravan.
8. Wait until water flows freely from the 'hot' kitchen tap. Allow to flow for a few more seconds to ensure release of any trapped air in the water system, then turn the tap off.

Repeat the same procedure with the 'cold' kitchen tap.

If the system has been drained, the above procedure **MUST** be repeated **EVERY** time the water container is filled.

Switch on the pump isolator at the control panel.

Once it has been properly connected, and a tap is turned on, the pump is activated automatically by a pressure switch.

Fault Finding

1. *Pump runs very noisy but does not pump water.* Likely to occur after water container has been refilled. Pump is air locked. *Cure:* unplug from socket allowing pump to flood, and reconnect by plugging in again. The correct sequence when refilling the container is to unplug, replace pump in container, then reconnect.
2. *Pump fails to deliver water.* The most likely cause will be air in the system. To remedy this, switch off the pump and shake the pump assembly in the water. Then switch on again. Alternatively, make sure the assembly is positioned fully into the housing.
3. *Pump does not run at all.* If not due to blown fuse or faulty connections, then most likely cause is excessive continuous running. *Cure:* replace pump.

Never allow the pump to run dry.

Never allow the pump to run continuously for more than 15 minutes.

Note: When refilling the water container, the pump assembly may be left plugged into the wall socket so that the pump can be kept off the ground by inserting the hose into the groove on the underside of the plug. But, the pump assembly **MUST** be unplugged **BEFORE** replacing the pump into the refilled water container.

STERILISING

When cleaning the water system at the start or the end of the season, it is advisable to use the sterilising fluid, e.g. Milton 2, Chempro SDP or similar. It is recommended that for this operation you use any empty filter body as the fluid reduces the effectiveness of a new filter.

Flush the system thoroughly to remove the effective fluid traces.

After sterilising the system at the start of the season it is recommended that a new filter cartridge is fitted.

NOTES

- Never allow the pump to run dry. Always ensure that the pump is submerged in the water or the life of the pump will be reduced.
- Before winter storage, the water system must be completely drained.
- Clean the water system at the start and



SERVICES

end of the season with sterilising fluid (see notes under sterilising).

Water System Winterisation

Caravans may be in use all year round, but when not in use, even for short periods, this procedure should be followed. One night of freezing temperatures is all that is required for expensive permanent damage to water system components.

- a. The whole system must be drained.
- b. Open kitchen taps. Lever taps should be lifted in central position, leave taps open permanently after system drain down.
- c. Open bathroom and shower taps (including shower on/off control rose) and leave open permanently after system drain down.
- d. Shake the shower head to remove the water held there and in the hose. At this point it is recommended to remove the shower head from the hose. Even the smallest amount of frozen water can result in the shower head cracking.
- e. Remove cold water drain plug (if fitted), normally located under the caravan near to the water inlet socket.
- f. If possible remove any remaining water from system plumbing at water inlet sockets and in between in-line pressure switch plumbing.

- g. Disconnect cartridge or in-line filters from plumbing.
- h. Submersible pumps should be shaken out and stored in a dry place.
- i. Drain the external shower bridge connection (including models without external shower) on the Ultraflow housing by inserting the shower connection or open the valve by means of a tool to push on the black rubber pad of the valve.

Cleaning the Water System and Portable Water Tanks

The water systems, and in particular storage tanks, in caravans are susceptible to contamination by bacteria if care is not taken with their use and cleaning. The symptoms caused by bacterial contamination are not purely limited to gastro-intestinal diseases, but may also manifest themselves as ear, nose, throat, eye or skin infections. It is therefore important that you carry out the following procedure prior to using the caravan each time, even if you boil or filter all water you use for drinking.

Water Containers

1. All water remaining in the container should be disposed of so that the container is empty.
2. The outside of the container should be thoroughly cleansed and washed down to

remove any dirt, dust or other contaminants. Water at a suitably hot temperature containing an appropriate detergent is recommended for this purpose.

3. Water should be placed in the container, swirled around, then emptied out.
4. The container should then be totally filled with water containing an appropriate disinfectant/sterilant solution and allowed to stand for the recommended contact time (e.g. Milton for 15 minutes).
5. The solution should be emptied from the container.
6. The opening of the container should be cleaned thoroughly with an appropriate pre-prepared wipe impregnated with a disinfectant/sterilant.
7. The container should be inverted whilst stored overnight (if possible).
8. The container must be filled with mains water only and mains water only should be used for the above cleaning procedure.
9. On no account should garden hoses be used to fill water tanks.

Water Systems

1. Drain down the system. (Open all taps to allow air in, enabling the system to drain quickly.)



2. Remove any water filters fitted, and replace with a short length of hose or empty filter cartridge (this will ensure the filter is not affected by the disinfectant/sterilant solution).
3. Fill the system by using the pump with a disinfectant/sterilant solution. (Check that the solution at full strength appears at all taps/showers). Allow to stand for the recommended period of time.
4. Drain the system down using the water systems internal flip switch located under the front off-side bed.
5. Thoroughly clean the outside of all taps/connectors with a cloth soaked in the disinfectant/sterilant.
6. Flush the system through with clean drinking water until no traces of disinfectant/sterilant can be detected at any tap.
7. Replace the filter.

Suitable sterilising chemicals are available from your caravan dealer, accessory shop, chemists or home-brew shops. It is not, however, recommended to use bleach or sodium metabisulphite.

Setting Up the Water System

1. Replace/close all drain valves.
2. Replace shower heads and tap spouts.
3. Close all taps.
4. Refit old filters:
 - a. Check all plumbing connections.
 - b. It is recommended at this point to sterilise your water container and flush the system through with sterilising fluid.

Note:

Frost damage cannot be claimed under warranty.



SERVICES

PRESSURE SWITCH

Operation

The pressure switch detects the opening or closing of any tap in the system and switches the pump on or off accordingly. It is located near the water heater.

To prime if fitted with a submersible pump:

1. Trapped air in the submersible pump will not allow the pump to prime. Air can be released by gently shaking the pump under water while the pump is in the water tank but is switched off.
2. If an external submersible pump is used, place the pump in the water before connecting to the side of the van.

At normal flow rates the pump should operate continuously — but at low rates the pressure switch will cycle on and off to maintain back pressure in the pipework.

Adjusting the pressure switch:

If the battery voltage is not constant, cycling may occur. This can be minimised by adjusting the switch's diaphragm sensitivity as follows:

1. With the system properly primed, close all taps and showers.

2. Leave the power supply turned on.
3. Tighten the adjusting screw (clockwise). The pump should now be running.
4. Partly open one cold tap to allow water to flow at about 1 pint per 15 seconds.
5. Now slowly loosen the adjusting screw until the switch starts to click. The switch will then be properly adjusted.

Helpful Hints

- a) If the pump will not run:
 - Pump could be faulty or a wire disconnected.
 - Check that the pump isolating switch is turned on.
- b) If the pump cycles on/off:
 - Battery voltage may be too low (at or below 10.5 Volts). Adjust switch (see text) and/or recharge battery.
 - Check for air or water leaks in taps and piping. Re-adjust pressure switch.
 - Non-return valve may be held open by grit.
- c) If a pump motor runs steadily and will not stop:
 - Battery voltage may be too low (at or below 10.5 volts)

- Check all connections in the pipe-work.
- Remove the adjusting screw, if motor still runs, pump is probably air locked. Turn off the isolator switch and reprime the pump (see text).

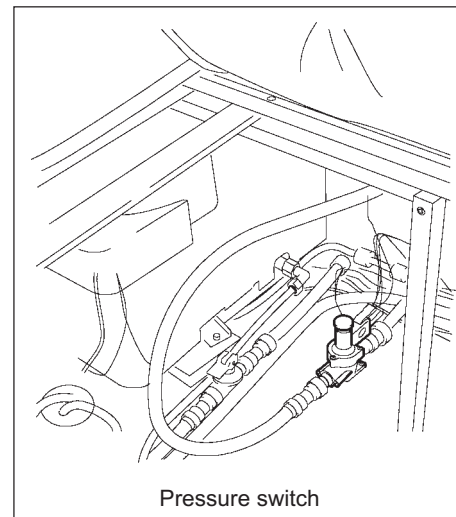

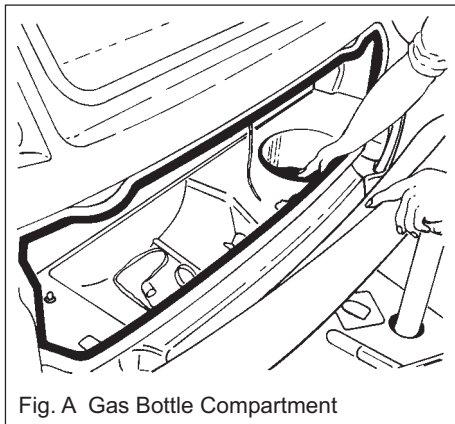

Fig. A Gas Bottle Compartment

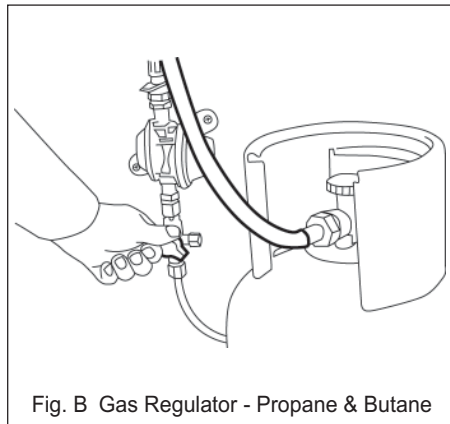

Fig. B Gas Regulator - Propane & Butane

GAS

GENERAL INFORMATION

Gas Bottles

Bottled Liquefied Petroleum Gas (LPG) is the most convenient portable source of fuel for your caravan.

Make sure that heating and cooking appliances and the gas cylinders are switched off before you move the caravan.

Regularly check flexible gas hose, joints and connections for tightness. Finally make sure that each gas appliance is working efficiently to the recommendations of the appliance manufacturers.

In all cases the cylinder contents are in liquid form under pressure from the gas above it, and the pressure is only dependent on the type of L.P.G. and its temperature.

When gas is supplied the pressure in the cylinder is slightly reduced and liquid "boils" off to restore the balance. This action cools the liquid and the cylinder, and condensation or even frost may sometimes be observed on the outside of the cylinder. The cylinder, when in use, is always cooler than the surrounding air so allow plenty of circulation in cool weather and do not cover the cylinder with a "cozy" in the winter.

Butane works satisfactorily at temperatures down to 2° C. Propane should be used for temperatures below this, therefore for all year round caravanners, Propane is of greater use.

There are different sizes of bottles available and it is better to consult your dealer for advice. Gas cannot be supplied from the bottle without an approved regulator.

Hoses connected from regulator to the caravan supply should be made from Neoprene and comply with EN1949. Hoses have a limited life and should be inspected regularly.

The gas cylinders have a recess in the gas bottle compartment into which the cylinders should be restrained by means of the straps provided.

If cylinders are used outwith this compartment you must ensure 1) they are adequately supported b) ventilation is not blocked c) damage will not be caused to fixtures and fittings.

Never use a gas cylinder on its side - always stand cylinders upright - keep them in the gas locker provided (Fig. A).

Please note that the Gas Locker Box is not a watertight compartment.



SERVICES

If you should suspect a gas leak turn off the gas at the bottle and ventilate the caravan by opening the door and windows. Do not operate anything electrical and remove everyone from the caravan until the gas has dispersed. It is part of your annual service to inspect all gas pipes and appliances.

Changing a Gas Cylinder

Before commencing to change a gas cylinder ensure that the valve on the cylinder is turned fully off. Turn off all gas operated appliances.

Remove the gas hose from gas cylinder.

Before refitting a gas cylinder, ensure that all gas operated appliances are turned off – particularly after winterisation. Ensure all connections are secure.

The regulator

Your caravan is fitted with a regulator (capacity 1.5kg/hr) as standard equipment (Fig. B). This is located in front gas bottle locker. The gas regulator has a working pressure of 30mbar and is suitable for both propane and butane liquefied petroleum gas.

Note: Regulator valves should always be in the 'OFF' position when towing.

The 30mbar bulkhead mounted regulator fitted to the caravan requires a 'pigtail' connector for use with UK LPG cylinders, see your dealer for details.

To effect a safe connection with a European cylinder, you will need to obtain a 'pigtail' connector appropriate to the cylinders available in the country you are visiting.

DO NOT use the conventional cylinder-mounted 28mbar/37mbar regulators as the gas pressure is not compatible with the appliances installed in your new caravan/motorhome.

Hoses

Inspect flexible hose(s) regularly for deterioration and renew, as necessary, with approved type. In any case not later than the expiration date marked on the hose. LPG hoses should be routinely replaced at

intervals not exceeding 5 years or as recommended in manufacturers' instructions. Any hoses that show signs of splitting, wear or damage should be replaced irrespective of age.

If the gas supply hose is to be left disconnected for an extended period ensure the open end is protected against the entry of dirt or insects.

Duo Control Regulator (Clubman/Delta)

The DuoControl is a safety gas pressure regulation system with automatic changeover for connecting to two gas cylinders for caravans and motorhomes (Fig C).

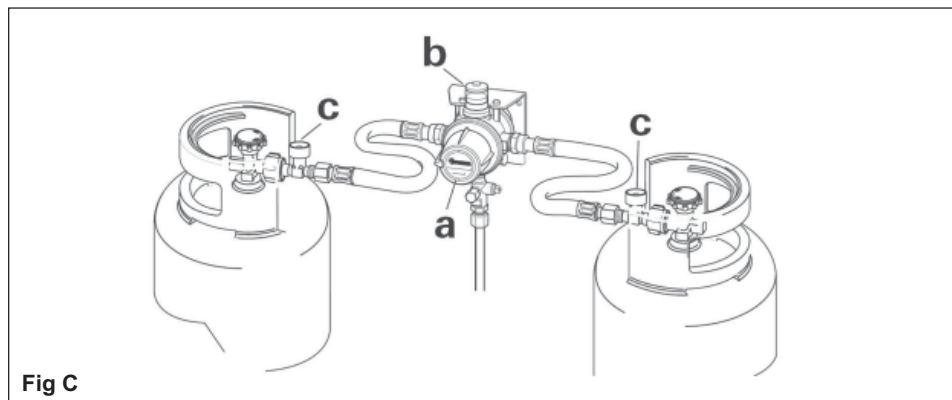

Fig C



Operation

Use the control knob (a) to manually select which cylinder will be operating and which will be held in reserve.

The mica window (b) indicates the status of the operating cylinder:

green = Gas from the operating cylinder.

red = Gas from the reserve cylinder.

- Open gas remote switch if present.
- For example, turn control knob (a) to the left until it stops (left connection is operating cylinder).
- Connect gas cylinders and make sure all hose connections are in good condition.
- Open the valves on both gas cylinders.
- If fitted, press SBS (c) on high pressure hose.
- The display in the mica window will turn green.

Changeover

As soon as the pressure in the operating cylinder falls below 0.6 bar, the DuoControl regulator automatically switches over and begins taking gas from the second gas cylinder. The display in the mica window turns red.

In extreme cold or when a large amount of gas is consumed from the cylinder over a long period of time, the gas pressure may fall below 0.6 bar even though there is still some gas left in the cylinder. This may result in gas being taken from both gas cylinders simultaneously.

If needed, you can change the position of the control knob at any time. Always turn control knob (a) as far to the left or right as it will go (an intermediate position will cause gas to be removed from both gas cylinders simultaneously).

Changing the LPG Cylinder

DuoControl enables replacement of an empty cylinder without interrupting the operation of devices currently consuming the gas. Non-return valves integrated into the inlet connecting piece prevent gas from escaping when only one gas cylinder is attached for a short time.

Please refer to your manual for more information on the DuoControl regulator.

TYPES OF GAS

Butane

Butane is supplied in the U.K. in blue bottles.

Butane is suitable for use at temperatures down to 2°C, but will not work below that temperature.

Propane

Propane is supplied in red bottles which have a left-hand threaded connector.

Propane will work at temperatures as low as -40°C and is therefore suitable for winter caravanning.

Make sure that heating and cooking appliances are turned off, and also the regulator at the gas cylinders before travelling.

Never allow modification of LPG systems and appliances except by qualified persons.



SERVICES

GAS SAFETY ADVICE

Facts about LPG

LPG is not poisonous.

Bi-products are harmless.

There is danger if all air and oxygen were excluded. (Ventilation holes must be kept clear at all times).

LPG has been given a smell by the manufacturers in order to identify leaks.

Awning Spaces LPG Appliance Exhaust

There is no danger of pollution of an enclosed awning space by the LPG exhaust from a refrigerator venting into it.

Space heaters may produce sufficient exhaust to pollute the awning space, if it is totally enclosed, from a general comfort, smell and hygiene point of view. In the extreme case there could be a build up of carbon dioxide to a dangerous level.

Caravan owners are advised to allow some fresh air circulation in the awning space when such appliances are in use.

PRECAUTIONS

- a) Never look for a leak with a match. Always use a soap solution or its equivalent when testing connections. Do not operate any electrical apparatus whatsoever, especially light switches. If the leak is not obvious, the caravan should be evacuated and qualified personnel consulted.
- b) Avoid naked lights when connecting or changing a cylinder.
- c) Check the flexible hose frequently.
- d) The gas is heavier than air and therefore sinks to the lowest point.
- e) Keep bottle gas containers outside (and protected against frost). If they must be kept inside make sure they are well away from heat.

Ventilation

Fresh air circulation should be allowed below the caravan when appliances are in use and when flues terminate below the floor to allow free evacuation of the products of combustion. At least three sides of the underfloor space should always be kept open and unobstructed especially by snow. Do not make any additional openings in the floor.

Fixed ventilation openings are sited under gas appliances in various locations in your tourer.

WARNING

Under no circumstances should fixed ventilation openings or gas appliance flues be obstructed in any manner as this could lead to a build up of dangerous carbon monoxide. Gas drop holes under appliances should also be kept clear at all times. Grilles and flues should be kept clean and free from dust.

All ventilation complies with BS EN1645 and vents should not be obstructed in any manner as this could lead to insufficient fresh air. In this case the confined atmosphere becomes depleted of oxygen which leads to the formation of the highly poisonous gas 'carbon monoxide'. Carbon Monoxide is odourless, colourless and tasteless and will rapidly cause unconsciousness and death with little or no warning prior to collapse. THERE IS NO DANGER WHEN ADEQUATE VENTILATION IS PROVIDED.



Roof-mounted Flue installations

All flue installations should be inspected once a year throughout their length for corrosion. Flues should be replaced if any sign of perforation is found. Ensure that the replacement is of an approved type.

CONNECTION

Ensure that the gas regulator is correctly connected to the gas cylinder in gas bottle compartment and that the hose is tight. Before turning on the gas supply, ensure that all gas operated equipment in the caravan is turned off.

Safety Hints

It is advisable to TURN OFF THE MAIN VALVE on the gas container when the caravan is left unattended for a period or is on tow, except where continuous operation appliances (such as a refrigerator) are in use. AVOID NAKED LIGHTS when connecting or changing a container. Make sure all appliances are turned off.

Space Heating Appliances

Space heating appliances are to be completely extinguished before the caravan is moved and are not to be used when the caravan is in motion. Portable heaters should not be used.

Manifold Locations

Heater and Water Heater manifold located underneath front O/S bed towards bulkhead.

Cooker and Fridge manifold located within compartment below cooker.

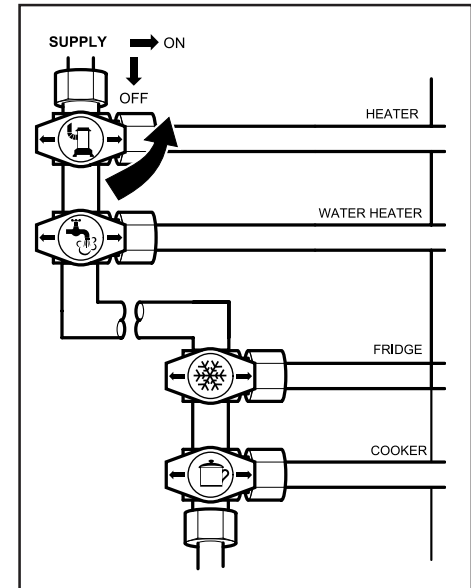



SERVICES

MAINS ELECTRICS

230V Mains Electric Equipment Usage

For your convenience and pleasure this touring caravan is fitted with a 230V mains electrical installation.

Please note: It is possible that all of the 230V mains electrical equipment may not be able to be operated simultaneously. A typical UK caravan park mains hook up point provides a maximum output of 16 amps, although 10 amps is more common and on some continental sites the available output may be as low as 5 amps. If your loading exceeds the site supply it may trip the park's circuit breaker. Please check the available mains output with your site operator.

The following items need to be added together if used simultaneously.

230V mains equipment typical consumption figures:

Fridge	0.5 amps
Charger	1.0 amps
Water heater (max)	5.7 amps
Blown air heaters	4.8 amps
Colour TV	2.5 amps
Microwave	3.5 amps
Air conditioning	4.0 amps
Truma Ultraheat (max)	8.3 amps
Kettle	3.2 amps
Alde central heating	10.0 amps

The mains wiring in Lunar caravans manufactured in the UK complies with the IEE Wiring Regulations, 17th edition, and is safe for the use in the UK. In the UK the on/off switching is always positioned in the live wire. Therefore when the switch is off the current is dead.

Correct polarity of the site supply should always be obtained by the use of a non-reversible plug and socket for connecting the cable to the caravan inlet.

Reverse polarity on overseas use: A plug in polarity tester is used to determine if the polarity is reversed, if so and the site connector is of the two pin type with the two metal strips for the earth, then the plug may be unplugged and inserted the other way round which will then reverse the polarity.

Unfortunately the overseas practice is not always to discriminate between live and neutral wires and the plugs are not necessarily non-reversible. They can be inserted the wrong way round. Consequently when switches are turned off the circuits are not dead. People may touch connections thinking that they are safe and they may still receive a shock.

A residual current device is already fitted to your Lunar Caravan. If a fault occurs and anyone makes indirect contact with a live lead the breaker should trip before a

dangerous voltage is apparent.

It is essential that you understand the workings of each electrical circuit. Check supply cable terminals are firm and secure.

Check supply cables for wear and damage. Do not attempt modifications to the caravan electrical installation to accommodate a double supply.

INSTRUCTIONS FOR ELECTRICITY SUPPLY

On Arrival at Caravan Site

1. Before connecting the caravan installation to the mains supply, check that:
 - (a) the main supply is suitable for your installation and appliances, i.e. 230 volts AC, frequency 50 Hertz.
 - (b) your installation will be properly earthed. Never accept a supply from a socket outlet or plug having only two pins, or from a lighting outlet.
 - (c) any residual current device (earth leakage circuit breaker) in the mains supply to the caravan has been tested within the last month. In case of doubt, consult the site owner or his agent.



Note: Always disconnect the electrical connector between the towing vehicle and the caravan before connecting an LV (low voltage) supply to the caravan and before charging the caravan battery by any other means.

2. Ensure that your caravan mains isolating switch (RCD) is in the off position. The MCB's are the breakers for the individual circuits.
3. Remove any cover from the electricity inlet provided on the caravan, and insert the connector of the supply flexible cable.
4. Remove any cover from the socket outlet provided at the site supply point, and connect the plug (at the other end of the supply flexible cable) to this. Switch on the main switch at the site supply point.

IN CASE OF DIFFICULTY CONSULT AN APPROVED ELECTRICAL INSTALLATION CONTRACTOR (WHO MAY BE THE LOCAL ELECTRICITY COMPANY). IT IS DANGEROUS TO ATTEMPT MODIFICATIONS AND ADDITIONS YOURSELF, LAMPHOLDER PLUGS (BAYONET-CAP ADAPTORS) SHOULD NOT IN ANY CIRCUMSTANCES BE USED.

On Leaving the Caravan Site

5. Reverse the procedure described in Paragraphs 3 and 4 above.

IT IS IMPORTANT THAT THE MAIN SWITCH AT THE SITE SUPPLY POINT SHOULD BE SWITCHED OFF, THE SUPPLY FLEXIBLE CABLE DISCONNECTED, AND ANY COVER REPLACED ON THE SOCKET OUTLET AT THE SITE SUPPLY POINT. IT IS DANGEROUS TO LEAVE THE SUPPLY SOCKET OR SUPPLY FLEXIBLE CABLE LIVE.

Periodically

6. Preferably not less than once a year, the caravan electrical installation should be inspected and tested and a report on its condition obtained as prescribed in the Regulations for Electrical Installations published by the Institute of Electrical Engineers.

Never allow modification of electrical systems or appliances except by qualified persons.

Outlet sockets located within the tourer should only be used with a dedicated appliance and not an independent unit.

No appliance shall be used outside when connected to an internal socket.

YOUR CARAVAN IS NOW SUPPLIED WITH 25 METRES OF MAINS CABLE TO COMPLY WITH BS EN1645.

FLEXIBLE WIRING

LIVE	BROWN
NEUTRAL	BLUE
EARTH	GREEN & YELLOW

FIXED WIRING

LIVE	BROWN
NEUTRAL	BLUE
EARTH	GREEN & YELLOW



SERVICES

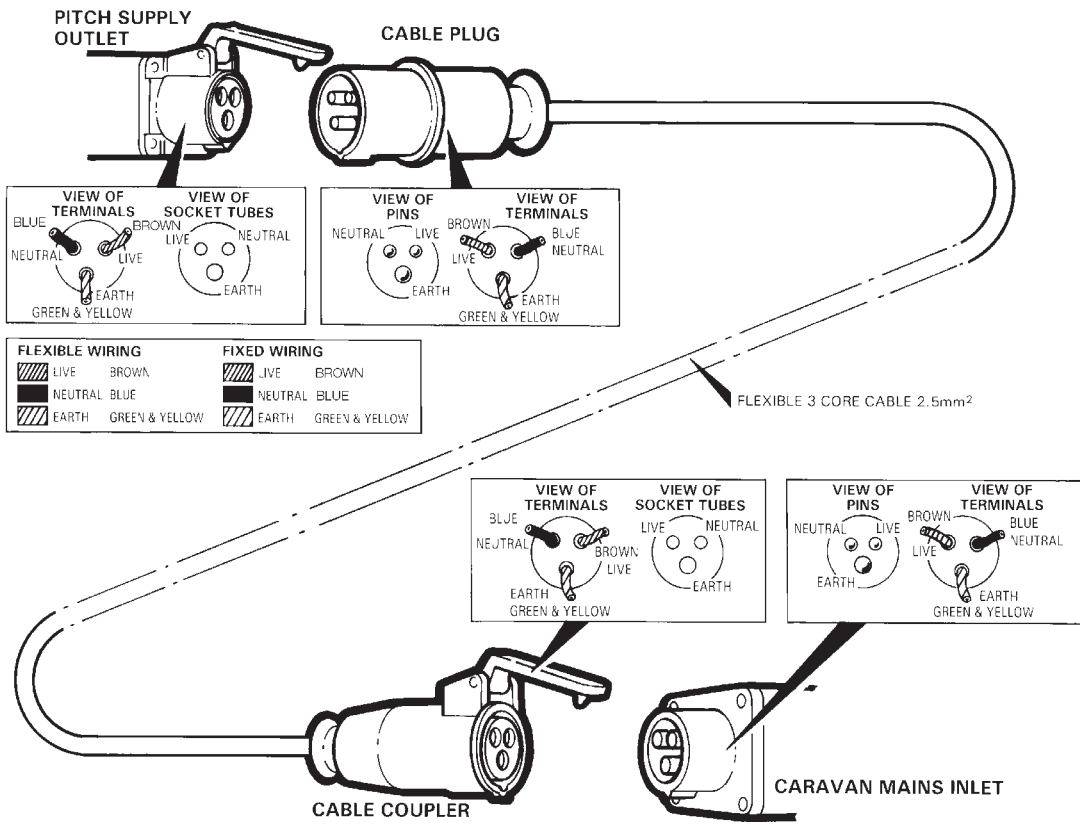

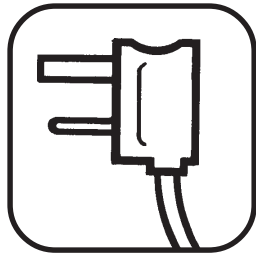

ELECTRICS

Power Control System	48
Lights	80
Battery	80
Use of Generators	81



ELECTRICS

EC500 POWER CONTROL SYSTEM (CLUBMAN, DELTA)

1 INTRODUCTION

This section of the handbook will guide you through the operation of the electrical system.

Further technical details are contained later in this document or in the supporting technical manual available from www.sargentltd.co.uk

For the safe operation of all electrical equipment within your Leisure Vehicle it is important that you read and fully understand these instructions. If you are unsure of any point please contact your dealer / distributor for advice before use.

The system has a number of key components that you will need to be familiar with before attempting to use the system, these are:

- **The EC500 series Power Supply Unit (PSU)** - a combined mains 230V / 12V consumer unit and controller located in the front bed box.
- **The EC370 series Control Panel (CP)** - a remotely located user control panel used to turn circuits on and off and to display battery and water tank information.

- **The PX-300 Battery Charger / Power Converter** – A separate, air cooled 300 Watt multi-stage power converter unit that charges the batteries and provides 12V DC power.
- **The C44 Road Light Fuse Box** - This small unit is located near the PSU. The unit houses fuses for the road lighting circuits and supplies from the tow vehicle and also has connectors for the optional alarm system and Automatic Trailer Control (ATC) unit.

2 USING THE SYSTEM

The PSU is located in the front offside bed box.

2.1 EC500 Power Supply Unit - Component Layout

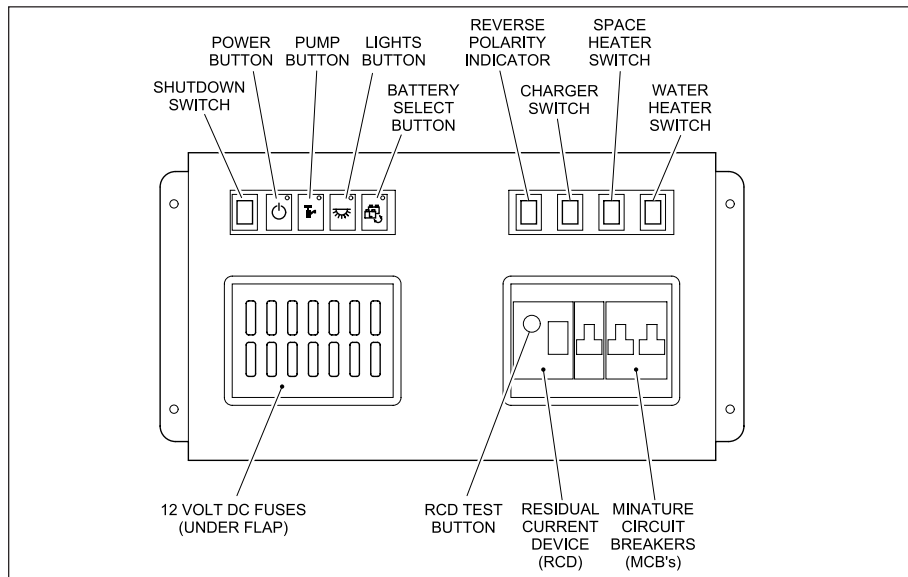



2.2 Activating the System

The EC500 system has a shutdown feature that should be used when the vehicle is in storage or is not being used for long periods of time. This allows the leisure electronics to be turned off when not required to save battery power. When in the off state the alarm and tracking system supplies are still active, most other supplies are turned off.

Before using the system please ensure the system shutdown switch is in the on position (button in).

PSU - 12V Controls

The black system shutdown button is shown on the left. In is on and out is off.

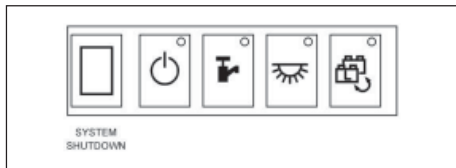

2.3 Connecting to the Mains 230V supply and Safety checks

For your safety it is IMPORTANT that you follow these connections instructions each time your Leisure Vehicle is connected to a mains supply. This section assumes that the system is complete and that a Leisure battery has been installed (see 3.3).

A) Ensure suitability of the Mains Supply. Your Leisure Vehicle should only be connected to an approved supply that meets the requirements of BS7671 or relevant harmonised standards. In most cases the site warden will hold information regarding suitability of supply. If using a generator you also need to comply with the requirements / instructions supplied with the generator. Please note that some electronic generators may not be compatible with your leisure system. Further generator operational information is contained elsewhere in this manual.

B) Switch the PSU internal Power Converter OFF. Locate the green 'Charger' power switch on the PSU and ensure the switch is in the off position (button out) before connection to the mains supply.

C) Connect the Hook-up Lead. Firstly connect the supplied hook-up lead (orange cable with blue connectors) to the Leisure Vehicle and then connect to the mains supply.

D) Check Residual Current Device operation. Locate the RCD within the PSU and ensure the RCD is switched on (lever in up position). Press the 'Test' button and confirm that the RCD turns off (lever in down position). Switch the RCD back to the on position (lever in up position). If the test button failed to operate the RCD see section 3.14.

E) Check Miniature Circuit Breakers. Locate the MCB's within the PSU (adjacent to the RCD) and ensure they are all in the on (up) position. If any MCB's fail to 'latch' in the on position see section 3.14.

F) Turn the PSU ON. Locate the black 'Shutdown' button and ensure it is in the on position (press button to change, button in = on, button out = off). Locate the green 'Charger' switch on the PSU and turn to the on position (press button to change, button in = on, button out = off). The charger switch will illuminate when turned on.

G) Check correct Polarity. Locate the 'Reverse polarity' indicator on the PSU and ensure that the indicator is NOT illuminated. If the indicator is illuminated see section 3.14. Please note that this indicator works in conjunction with the charger switch, so will only operate when the charger is on.

H) Check operation of equipment. It is now safe to operate the 12v and 230v equipment.



ELECTRICS

PSU - 230V Controls

RCD TEST
BUTTON

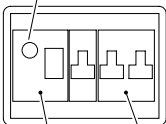

RESIDUAL
CURRENT
DEVICE
(RCD)

MINIATURE
CIRCUIT
BREAKERS
(MCB's)

Lever type switch, far left - Residual Current Device (RCD) and main 230V on/off switch.

Push button, far left - RCD test button.

3 x lever switches, right - Miniature Circuit Breakers (MCB). Note the lever colour and MCB rating may vary. See the safety and rating sticker adjacent to the PSU for further details.

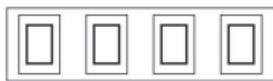

REVERSE
POLARITY

CHARGER

SPACE
HEATER

WATER
HEATER

Red indicator, far left - Reverse polarity warning indicator. This illuminates when the green charger is turned on (see below) and the 230V supply polarity is reversed (see 3.10).

Green push switch - Charger switch, this switch turns the 12V battery charger on or off. In is on out is off.

Amber push switch - Space heater switch, this switch turns the 230V supply to the space heater / combination heater / central heating system on or off. In is on out is off.

Clear push switch - Water heater switch, this switch turns the 230V supply to the separate water heater on or off. In is on out is off.



2.4 Control Panel - Component Layout

EC370 Digital Control Panel (LCD graphic display)

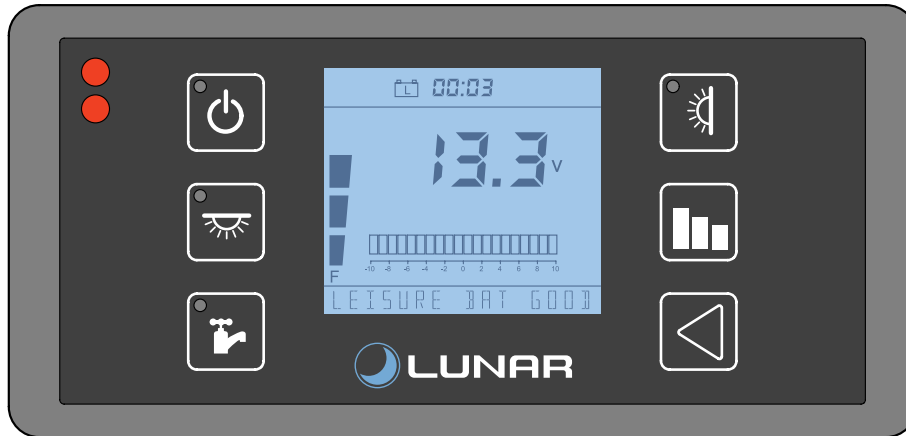



ELECTRICS

2.5 Control Panel Operation

Button	Button Description
	Power Button. Press the power button to turn the leisure power on. Press the button again to turn the power off. The adjacent LED will illuminate when the power is on, and also the voltage of the selected battery will be displayed on the screen. When the car engine is running this LED will flash to indicate the leisure battery is being charged.
	Pump Button. With the power on, press the pump button to turn the water pump on. Press the button again to turn the pump off. The adjacent LED will illuminate when the pump is on, and also the level of the water tank will be displayed on the screen (if the optional onboard water tank is fitted). This LED may also flash during tank filling operations, see 3.6 for further details.
	Light Button. With the power on, press the light button to turn the main internal lighting on. Press the button again to turn the lights off. The adjacent LED will illuminate when the lights are on. The lights will be turned on and off automatically each time the power button is operated.
	Awning Light Button. With the power on, press the awning light button to turn the awning light on or off. The adjacent LED will illuminate when the light is on.
	Levels / scroll button. Use this button to scroll through the various levels screens / menu items or to cancel alarms / warnings. Note: The screen illumination / backlight will turn off after a period of time. Press the levels button or wave your hand in front of the illumination sensor to reactivate the illumination.
	Select button. Use this button to select options/items or to change settings.
	Illumination sensor. With the power turned on, the illumination sensor detects the presence of your hand when it gets within 100mm of the sensor. The sensor is located at the top left of the control panel. Simply wave your hand in front of the sensor to activate the screen illumination.

2.6 Operation while driving

The EC500 system is designed to shutdown parts of the system whilst the engine is running. This is to meet Electro Magnetic Compatibility (EMC) regulations and to ensure the safe operation of the system.

Please ensure the system shutdown switch on the PSU is in the “on” (button in) position before driving (see 2.2). This will ensure the electronic system is active and will therefore be able to control the charging process, supply the refrigerator and monitor other system circuits.

If you hear a warning buzzer when the engine is started, please see the control panel display for details and also refer to section 3.8.



3 System Technical Information

The following section provides further technical information relating to the electrical system.

3.1 Residual Current Device & Miniature Circuit Breakers

The Residual Current Device (RCD) is basically provided to protect the user from lethal electric shock. The RCD will turn off (trip) if the current flowing in the live conductor does not fully return down the neutral conductor, i.e. some current is passing through a person down to earth or through a faulty appliance.

To ensure the RCD is working correctly, the test button should be operated each time the vehicle is connected to the mains supply (see section 2.3)

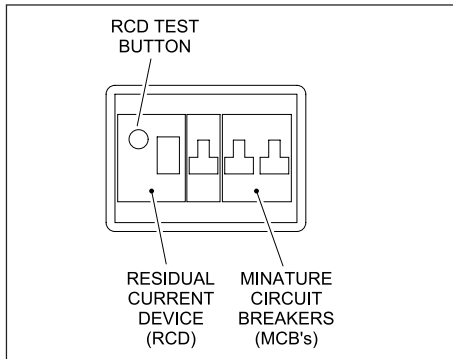

The Miniature Circuit Breakers (MCB's) operate in a similar way to traditional fuses and are provided to protect the wiring installation from overload or short circuit. If an overload occurs the MCB will switch off the supply. If this occurs you should investigate the cause of the fault before switching the MCB back on.

The following table shows the rating and circuit allocation for the three MCB's

MCB	Rating	Description (cable colour)
1	10 Amps	230v Sockets (white)
2	16 Amps	Combination water heater / central heating system (yellow) Extra 230V sockets (white)
3	10 Amps	Fridge (black) 12V Charger (internally socketed)



3.2 Battery Charger

The EC500 system incorporates an intelligent three-stage battery charger / power converter.

During stage 1 the battery voltage is increased gradually while the current is limited to start the charging process and protect the battery. At stage 2 the voltage rises to 14.4V to deliver the bulk charge to the battery. When the battery is charged, the voltage is decreased at stage 3 to 13.6V to deliver a float charge to maintain the battery in the fully charged state. The charger can be left switched on continuously as required but if you are using your caravan as a permanent home please contact Sargent for advice.

The battery charger / power converter also provides power to the leisure equipment when the mains supply is connected. This module supplies DC to the leisure equipment up to a maximum of 25 Amps (300 Watts), therefore the available power is distributed between the leisure load and the battery, with the leisure load taking priority as per the following example

Leisure load	Available power for battery charging
5A	20A
10A	15A
15A	10A
20A	5A

WARNING: Under heavy loads the charger case may become hot. ALWAYS ensure any ventilation slots have a clear flow of air. Do not place combustible materials against/ adjacent to the charger.

3.3 Leisure Battery

3.3.1 Type / Selection

For optimum performance and safety it is essential that only a proprietary brand LEISURE battery is used with a typical capacity of 75 to 120 Ah (Ampere / hours). A normal vehicle battery is NOT suitable. This battery should always be connected when the system is in use.

The PSU is configured to work with standard lead acid leisure batteries, and in most cases is also compatible with the latest range of Absorbed Glass Matt (AGM) batteries. Before fitting non-standard batteries please check that the charging profile described in 3.2 is suitable for the type of battery by referring to the battery documentation or battery manufacturer.

The battery feed is fitted with an inline fuse between the battery and the electrical harness, and is usually located immediately outside the battery compartment or within 500mm of the battery. The maximum rating of this fuse is 20A.

3.3.2 Installation & Removal

Always disconnect the 230v mains supply and turn the PSU green charger switch to the off position (button out) before removing or installing the battery.

When connecting the battery, ensure that the correct polarity is observed (black is negative [-] and red is positive [+]) and that the terminals are securely fastened. Crocodile clips must not be used.

WARNING: Explosive gases may be present at the battery. Take care to prevent flames and sparks in the vicinity of the battery and do not smoke.

3.3.3 Operation / Servicing

Under normal circumstances it should not be necessary to remove the battery other than for routine inspection of the terminals and “topping up” of the battery fluid where applicable. Please see instructions supplied with the battery.

Note: Do not over discharge the battery. One of the most common causes of battery failure is when the battery is discharged below the recommended level of approximately 10v. Discharging a battery below this figure can cause permanent damage to one or more of the cells within the battery.



To prevent over discharge, the EC500 system incorporates a battery protect circuit that warns the users and then disconnects the batteries when they fall below set values.

3.4 Generator Usage

Caution should be used before connecting a generator to your caravan or motorhome.

WARNING: Never start or stop the generator while electrical loads are connected and switched on. Start the engine, let it stabilise and then connect the electrical load. To stop the engine, disconnect the electrical load and let engine stabilise before switching off.

Whilst some generators use electronic inverter technology, others use a more basic principle to generate the 230V supply. Preference should be to choose a generator which produces a consistent sinusoidal wave form with accurate voltage control.

The Reverse Polarity warning light on the PSU may illuminate when using a Generator. This is a normal side effect when using some types of generator. Instead of connecting the neutral conductor to earth, some generators centre tap the earth connection making both neutral and live conductors 110V above earth. This 110V difference causes the neon polarity indicator to illuminate.

In most cases it is safe to use a generator, but please consult the generator handbook for further information.

3.5 Solar Charge Management

The EC500 PSU incorporates a built-in solar charge monitor which will measure and display the current being generated by an attached solar panel (when fitted). For this display to work correctly the solar panel must be connected via a suitable solar regulator to the provided solar panel connection and not connected direct to the battery.

3.6 Water System Operation - Optional Tank Fill Feature

With the optional onboard water tank installed the system may also include an automatic tank fill/refill feature which operates as follows:

3.6.1 One shot fill

With the water pump turned OFF, when the tank fill feature is turned on at the control panel (see 4.4) 12V power is supplied to the tank filling pump. At the same time a timer is started and counts up in seconds and the LED next to the pump switch starts to flash indicating that filling has started.

Water starts to flow from the water carrier (i.e. Aquarol) into the internal tank.

If the 100% level is reached the filling pump is turned off, the timer is stopped and the tank fill feature is turned off (pump LED turns off).

If the tank filling pump runs continuous for 300 seconds (5 minutes) or more, then the

tank filling pump is turned off and the timer is stopped (pump LED stops flashing). This is to protect the tank filling pump.

3.6.2 Continuous fill/refill

During this process you do need to monitor the water level in the water carrier.

With the main water pump turned ON, when the tank fill feature is turned on at the control panel (see 4.4) 12V power is supplied to the tank filling pump. At the same time a timer is started and counts up in seconds and the LED next to the pump switch starts to flash fast indicating that filling has started.

Water starts to flow from the water carrier into the internal tank.

If the 100% level is reached the filling pump is turned off, the timer is stopped and then reset to zero. The pump LED stops flashing.

The process will restart if water is used from the internal tank causing the level to drop below 100%.

If the tank filling pump runs continuous for 300 seconds (5 minutes) or more, then the tank filling pump is turned off and the timer is stopped (pump LED stops flashing). This is to protect the tank filling pump.

The process can be restarted by turning the main pump off and then on again (after refilling the water carrier).



ELECTRICS

3.7 Awning Light Operation

The awning light is controlled by the control panel awning light button. The awning light is also linked to the optional alarm system to enable remote control with the alarm fob.

3.8 System Warnings

The system incorporates a number of warnings that are active at specific times. These are summarised below and also covered by relevant sections of this manual.

Warning	When	Type
Fresh water level low	With pump turned on and fresh water level low (less than 25% full)	Message on screen and 30 second audible beep.
Leisure battery voltage low	With control panel power on and leisure battery selected (as active battery) and the voltage level falls below 10V.	Message on screen and 30 second audible beep.
	With control panel power on and leisure battery selected (as active battery) and the voltage level falls below 9V.	Message on screen and 30 second audible beep. If no action taken after 30 seconds then the system will switch the power off to prevent severe discharge of the battery.
	<p>Note: This is an emergency cut off level to protect the battery from severe damage. You should not rely on this cut off level during normal operation, but manage your power consumption to a discharge level of 11.5V or above.</p> <p>This cut off only applies to power drawn from the battery by the leisure equipment that is controlled by the control panel power switch; it will not protect the battery from discharge by permanently connected equipment.</p>	



Warning	When	Type
Leisure battery voltage high	With control panel power on or off and leisure battery is selected (as active battery) and the voltage level rises above 15V	Message on screen and repeated beeps from the control panel. The beeping will not stop until the fault is cleared.
Vehicle battery warnings	If the vehicle battery is selected instead of the leisure battery, then the same warnings described above for the leisure battery are applied to the vehicle battery.	
Engine running	When the engine is started the system power will be turned off	Message on screen, Leisure & Vehicle battery symbols indicating both batteries are connected for charging. The leisure battery voltage is also shown on screen.
Mains lead (hook-up cable) still connected/plugged in	When the engine is started the system and the mains cable is still plugged in and the charger is switched on.	Message on screen and repeated beeps from the control panel. The beeping will not stop until the hook-up lead is removed.



ELECTRICS

3.9 12 Volt DC Fuses

WARNING: When replacing fuses always replace a fuse with the correct value. NEVER replace with a higher value/rating as this could damage the wiring harness. If a replacement fuse 'blows' do not keep replacing the fuse as you could damage the wiring harness. Please investigate the fault and contact your dealer.

The table opposite shows the fuse allocation for the 15 fuses fitted to the PSU. Please note that fuses are dependant on PSU versions, so not all fuses may be present or used.

Fuse	Rating	Fuse Colour	Description
1	10 Amps	Red	Toilet
2	5 Amps	Tan	Ignitions
3	10 Amps	Red	Motorhomes Only - Electric Step
4	10 Amps	Red	Water Pumps
5	10 Amps	Red	Permanent Supplies
6	20 Amps	Yellow	Leisure Battery
7	20 Amps	Yellow	Vehicle Battery
8	10 Amps	Red	Fans / Heater
9	10 Amps	Red	Power Circuits
10	10 Amps	Red	Lighting Circuit 1
11	10 Amps	Red	Lighting Circuit 2
12	10 Amps	Red	Motorhome only - En-route Circuits
13	10 Amps	Red	Motorhome only - Tank Heaters
14	10 Amps	Red	Tank fill Solenoid
15	25 Amps	White	Charger (note this fuse is fitted inside the PSU)

The following table shows details of the fuse(s) located at the Leisure battery.

Fuse	Rating	Fuse Colour	Description
Battery 1	20 Amps	Yellow	Fuse remotely located near battery



The following table shows details of the fuse(s) located at the Road Light fuse box

Fuse	Rating	Fuse Colour	Description
1	20 Amps	Yellow	Fridge Supply 12V
2	5 Amps	Tan	Left Hand Tail Lights
3	5 Amps	Tan	Right Hand Indicators
4	5 Amps	Tan	Fog Lights
5			Spare location
6	20 Amps	Yellow	Car Battery Supply 12V
7	5 Amps	Tan	Right Hand Tail Lights
8	5 Amps	Tan	Left Hand Indicators
9	7.5 Amps	Brown	Stop Lights
10	5 Amps	Tan	Reverse Lights

3.10 Common Fault Table

Fault	Possible Cause	Proposed Fix
No 230 volt output from PSU	Connecting lead between the site and Leisure Vehicle not connected	Check and connect lead as per 2.3C
	RCD switched off	Reset RCD as per 2.3D
	RCD not operating correctly	Check supply polarity; if the RCD continues to fail contact your Dealer as there is probably an equipment or wiring fault
	MCB switched off	Reset MCB by switching OFF (down position) then back ON (up position), if the MCB continues to fail contact your Dealer as there is probably an equipment or wiring fault
	No or deficient supply from site	Contact site Warden for assistance
	Other fault	Contact your Dealer.



ELECTRICS

3.10 Common Fault Table (continued)

Fault	Possible Cause	Proposed Fix
Reverse Polarity light is illuminated on PSU	Mains Supply reversed?	The reverse polarity light is designed to illuminate when the Live and Neutral supply has been reversed/crossed over. If the light illuminates there is a problem with the site supply or the cable connecting the supply to your vehicle. The light is designed to work on UK electrical supplies (where the neutral conductor is connected to earth at the sub station). If you are using your vehicle outside the UK this light may illuminate when no fault exists. In these cases consult the site warden for advice.
	Generator being used	'The Reverse Polarity warning light is on when using my Generator'. This is a normal side effect when using some types of generator. Instead of connecting the neutral conductor to earth, some generators centre tap the earth connection making both neutral and live conductors 110V above earth. This 110V difference causes the neon polarity indicator to illuminate. In most cases it is still safe to use the generator, but please consult the generator handbook for further information.
Control Panel problems	Control panel has no display	Backlight/illumination may have switched off. Press the select button to reactivate the backlight. Check batteries and fuses, turn PSU shutdown switch and charger switch on and ensure mains supply is connected. Check control panel connecting lead at PSU and behind Control Panel. Contact your Dealer
	12v Power turns off	Battery protect feature has operated to protect the Vehicle battery and or the Leisure battery. See 3.8 Engine has been started, all equipment has been disconnected to meet EMC requirements. See 2.7
	Control panel locked/ erratic function	Observe control panel handling instructions. Control panel software may have crashed. Reboot control panel by turning off the PSU isolate switch. Wait 30 seconds then turn the switch back on.
No 12 volt output from PSU	No 230V supply	Check all above.
	Charger not switched on	Turn charger switch on, switch will illuminate
	Battery not connected and / or charged	Install charged battery as per ??
	Power button on control panel not switched on	Turn power on at control panel
	Battery flat / Battery fuse blown	Recharge battery, check fuses, check charging voltage is present at battery.
	Fuse blown	Check all fuses are intact and the correct value fuse is installed as per fuse table
	Equipment switched off / unplugged	Check equipment is switched on and connected to the 12V supply.



3.10 Common Fault Table (continued)

Fault	Possible Cause	Proposed Fix
	PSU overheated / auto shutdown operated	Reduce load on system. Allow PSU to cool down. PSU will automatically restart when cool.
	Other fault	Contact your Dealer.
Pump not working	Fuse blown	Replace fuse with correct value as per fuse table.
	Pump turned off	Turn pump on by pressing the pump button at the control panel.
	Setting incorrect	Both the internal and external pump feeds are controlled from the control panel. To alter the setting of the pump switch see your dealer. Ensure the setting matches your desired requirement.

3.11 Contact details

Sargent Electrical Services Limited, provide a technical help line during office hours. Please contact 01482 678981 if you require technical help. For out of hour support please refer to the tech support section of the Sargent web site www.sargentltd.co.uk.

4 EC370 Control Panel

In addition to the information contained in section 2.5 (Control Panel Operation), the following section provides further detail information.







4.1 Screen Illumination Operation

The screen illumination (backlight) is turned on and off automatically. Pressing the levels button or waving your hand in front of the illumination sensor will reactivate the illumination.

4.2 Header Area



The header area of the screen shows the following information;

	Tank fill turned on. This symbol indicates that the tank fill feature is switched on. This is only available when the optional onboard water tank is fitted.
	Mains power on. This symbol indicates that the mains supply is connected and the 12V charger is turned on.
	Leisure battery selected. This symbol indicates that the leisure battery is selected as the battery to use or to charge. This is the default setting.
	Clock display. This shows the current time in a 24 hour format.
	Vehicle battery selected. This symbol indicates that the vehicle battery is selected as the battery to use or to charge. This is only available when the car is connected and the vehicle battery has been manually selected.
	Solar power. This symbol is displayed when the optional solar panel is supplying power to the leisure battery.
	This symbol is not used.



ELECTRICS

4.3 Footer Area









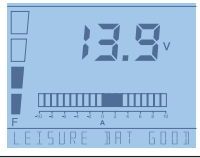

LEISURE BAT GOOD

The footer area of the screen shows details of the current information screen, and may also show additional information during specific operations.

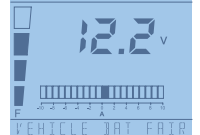
4.4 Information Area

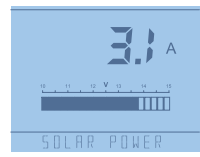
The main information area can display a variety of system information screens. These have been designed to present the information in a clear and concise form, while retaining technical detail for the more advanced users.

The selected screen can be changed by using the levels / scroll button and work on a continuous loop basis (when the last screen is reached the scrolling returns to the first). The selected screen may be changed automatically by the system depending on the action being performed.

Screen 1 - Leisure Battery	 	<p>Here leisure battery information is shown. The digit display shows the battery voltage. The bar display shows the battery current in Amps. A positive value shows the battery being charged and a negative value shows the battery being discharged. If the optional onboard water tank is fitted the display also shows the fresh water level on the left side. This level display is continuously refreshed if the water pump is turned on. The footer area shows a guide to the battery charge condition (i.e. POOR, FAIR, GOOD, CHARGING). Pressing the select  button will swap the display elements so that the digit display shows the battery current and the bar shows battery voltage. Pressing the levels  button to move to the next screen.</p>
2 - Vehicle Battery		<p>Here, if the tow car is connected, the vehicle battery information is shown similar to the leisure battery (see above). Again, pressing the select button  will swap the display elements. Pressing the levels  button to move the the next screen.</p>
3 - Solar Power		<p>The 3rd screen shows information relating to the solar panel (when fitted). The digital display shows the current being generated by the solar panel (measured in Amps). The bar display shows the battery voltage. When the solar panel is generating current the sun logo  is also displayed in the header area. Pressing the select  button will swap the display elements. Pressing the levels  button to move to the next screen.</p>



4 - Select Battery		<p>Here you can select which battery to use or charge.</p> <p>By default the leisure battery is automatically selected. If the mains supply is connected and the charger turned on, this battery will also be charged.</p> <p>If you need to select the vehicle battery and the tow car is connected, press the select button to change the selected battery from leisure to vehicle (or vice versa).</p> <p>The relevant symbol or will be shown in the header area.</p> <p>Information relating to the selected battery is shown on the screen.</p> <p>Pressing the levels button to move to the next screen.</p>
5 - Dimming Adjust		<p>Here you can adjust the dimming level of the dimmable lights.</p> <p>Press and release the select button to toggle the light level from 100% (full) to 0% (off).</p> <p>Press and hold the select button to alter the light level on 10% steps. Release the button when the desired level is reached. This level will be remembered while the system is powered up. It is reset to 100% when the system is shutdown.</p> <p>Pressing the levels button to move to the next screen.</p>
6 - Tank Fill		<p>This screen is only available when the optional onboard water tank is fitted.</p> <p>Press and release the select button to toggle the setting on or off. When turned on the automatic tank fill feature will operate (see 3.6).</p> <p>Pressing the levels button to move to the next screen.</p> <p>Here you can adjust the hour display.</p>



ELECTRICS

7 - Adjust Hour		<p>Here you can adjust the hour display.</p> <p>Press the select button to increase the value by 1. Press and hold the button to rapidly increase the value.</p> <p>Pressing the levels button to move to the next screen.</p>
8 - Adjust Minute		<p>Here you can adjust the minute display.</p> <p>Press the select button to increase the value by 1. Press and hold the button to rapidly increase the value.</p> <p>Pressing the levels button to move to the next screen.</p>
9 - System Info		<p>Here you can view the control panel model number (ie. EC370)</p> <p>Press the select button to increase the value by 1. Press and hold the button to rapidly increase the value.</p> <p>Pressing the levels button to move to the next screen.</p>

The system can display a number of warnings. The control panel will beep and display the appropriate message. Press the levels button to cancel the warning.



5 TECHNICAL DATA & APPROVALS

5.1 Outline specification - EC500PSU & EC370 Control Panel

INPUT 230V	230 Volts / 0 to 16 Amps	+ / - 10%
OUTPUT 230V	RCD protected, 3 x MCB outputs of 1 x 16A and 2 x 10A Separate switched channels for water heater, space heater and charger	
INPUT 12V	2 x 20A battery inputs via 2 x 4 way connectors	
SOLAR INPUT	1 x Dedicated solar panel input (20 to 100W panel) via a 2 way connector	
OUTPUT 12V	25A total output via multiple switched channels protected by 14 fused outputs	
CHARGER	Input 220-240 Volts AC +/- 10%, Frequency 50 Hz +/- 6%, Current 3A max. DC Output 13.6 to 14.4 Volts nominal, Current 25 Amps max (300 Watts) Overall size (HxWxD) 50 x 250 x 135mm	Fixing centres 128*128mm 1.2 kg
Signal INPUT	4 x Fresh water level, 1 x Engine running, plus multiple vehicle connections	Fresh water negative sensed
Data IN / OUT	CANBUS Data communication and power to Control Panel via 6 way connector	
IP rating	IP31	
Operating temperature	Ambient 0 to 35° Centigrade PSU case temperature with full load 65°C Max	Automatic shutdown and restart if overheated/overloaded
EC500 PSU	Overall size (HxWxD) 315 x 195 x 150mm Clearances 75mm above, 50mm left and right	Weight 2.9kg
EC370 Control Panel	Overall size (HxWxD) 80 x 194 x 25mm Cut-out size (HxW) 60 x 165mm	Fixing centres 190mm Weight 180g



ELECTRICS

EC175 POWER CONTROL SYSTEM (QUASAR, LEXON, ARIVA & STELLAR)

1 INTRODUCTION

This section of the handbook will guide you through the operation of the electrical system.

Further technical details are contained later in this document or in the supporting technical manual available from www.sargentltd.co.uk

For the safe operation of all electrical equipment within your Leisure Vehicle it is important that you read and fully understand these instructions. If you are unsure of any point please contact your dealer / distributor for advice before use.

The system has a number of key components that you will need to be familiar with before attempting to use the system, these are:

- **The EC175 series Power Supply Unit (PSU)** - a combined mains 230V / 12V consumer unit and controller located in the front bed box.
- **The EC360 or EC350 series Control Panel (CP)** - a remotely located user control panel used to turn circuits on and off and to display battery and water tank information.

2 USING THE SYSTEM

The PSU is located in the front offside bed box.

2.1 EC175 Power Supply Unit - Component Layout

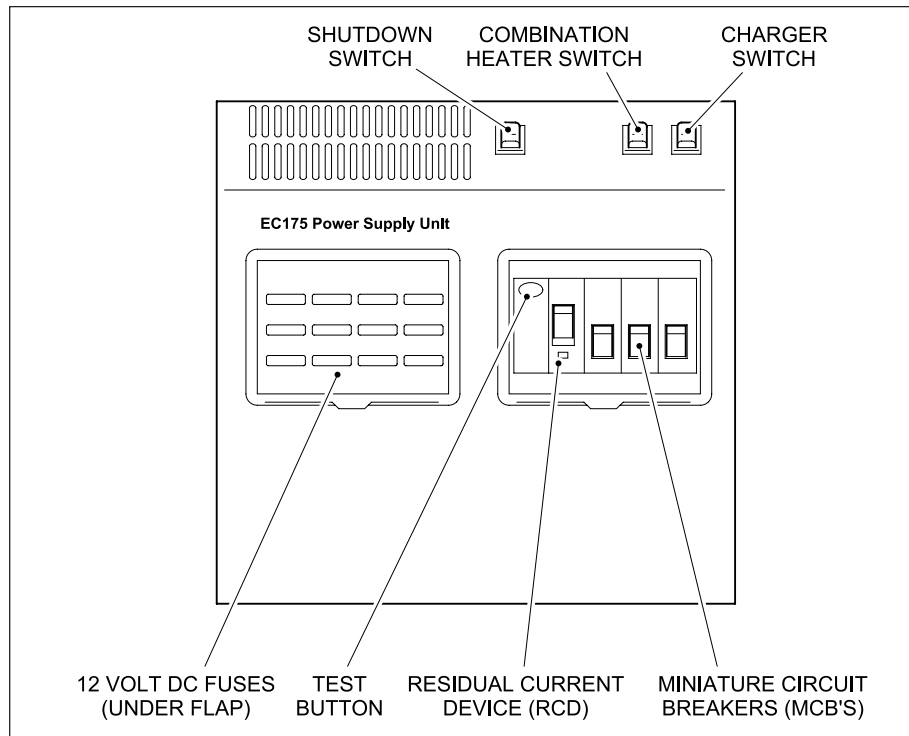



2.2 Activating the System

The EC175 system has a shutdown feature that should be used when the vehicle is in storage or is not being used for long periods of time. This allows the leisure electronics to be turned off when not required to save battery power. When in the off state the alarm and tracking system supplies are still active, most other supplies are turned off.

Before using the system please ensure the system shutdown switch is in the on position (button in).

PSU - 12V Controls

The black system shutdown button is shown on the left. In is on and out is off.

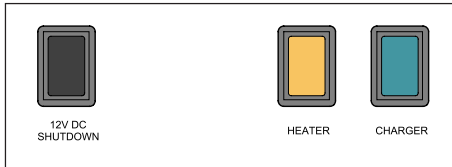

The other two switches are for 230V.

2.3 Connecting to the Mains 230V supply and Safety checks

For your safety it is IMPORTANT that you follow these connections instructions each time your Leisure Vehicle is connected to a mains supply. This section assumes that the system is complete and that a Leisure battery has been installed (see 3.3).

A) Ensure suitability of the Mains Supply. Your Leisure Vehicle should only be connected to an approved supply that meets the requirements of BS7671 or relevant harmonised standards. In most cases the site warden will hold information regarding suitability of supply. If using a generator you also need to comply with the requirements / instructions supplied with the generator. Please note that some electronic generators may not be compatible with your leisure system. Further generator operational information is contained elsewhere in this manual.

B) Switch the PSU internal Power Converter OFF. Locate the green 'Charger' power switch on the PSU and ensure the switch is in the off position (button out) before connection to the mains supply.

C) Connect the Hook-up Lead. Firstly connect the supplied hook-up lead (orange cable with blue connectors) to the Leisure Vehicle and then connect to the mains supply.

D) Check Residual Current Device operation. Locate the RCD within the PSU and ensure the RCD is switched on (lever in up position). Press the 'Test' button and confirm that the RCD turns off (lever in down position). Switch the RCD back to the on position (lever in up position). If the test button failed to operate the RCD see section 3.1 & 3.8.

E) Check Miniature Circuit Breakers. Locate the MCB's within the PSU (adjacent to the RCD) and ensure they are all in the on (up) position. If any MCB's fail to 'latch' in the on position see section 3.1 & 3.8.

F) Turn the PSU ON. Locate the black 'Shutdown' button and ensure it is in the on position (press button to change, button in = on, button out = off). Locate the green 'Charger' switch on the PSU and turn to the on position (press button to change, button in = on, button out = off). The charger switch will illuminate when turned on.

G) Check operation of equipment. It is now safe to operate the 12v and 230v equipment.



ELECTRICS

PSU - 230V Controls

RCD TEST
BUTTON

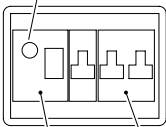

RESIDUAL
CURRENT
DEVICE
(RCD)

MINATURE
CIRCUIT
BREAKERS
(MCB's)

Lever type switch, far left - Residual Current Device (RCD) and main 230V on/off switch.

Push button, far left - RCD test button.

3 x lever switches, right - Miniature Circuit Breakers (MCB). Note the lever colour and MCB rating may vary. See the safety and rating sticker adjacent to the PSU for further details.

Green push switch - Charger switch, this switch turns the 12V battery charger on or off. In is ON out is OFF.

Amber push switch - Heater switch, this switch turns the 230V supply to the space heater / combination heater / central heating system on or off. In is ON out is OFF.

Note the far left 12V DC Shutdown switch is covered in section 2.2.



12V DC
SHUTDOWN



HEATER



CHARGER

2.4 Operation while driving

The EC175 system is designed to shutdown parts of the system whilst the car engine is running. This is to meet Electro Magnetic Compatibility (EMC) regulations and to ensure the safe operation of the system.

Please ensure the system shutdown switch on the PSU is in the “on” (button in) position before towing (see 2.2). This will ensure the electronic system is active and will therefore be able to control the charging process, supply the refrigerator and monitor other system circuits.



2.5 Control Panel - Component Layout



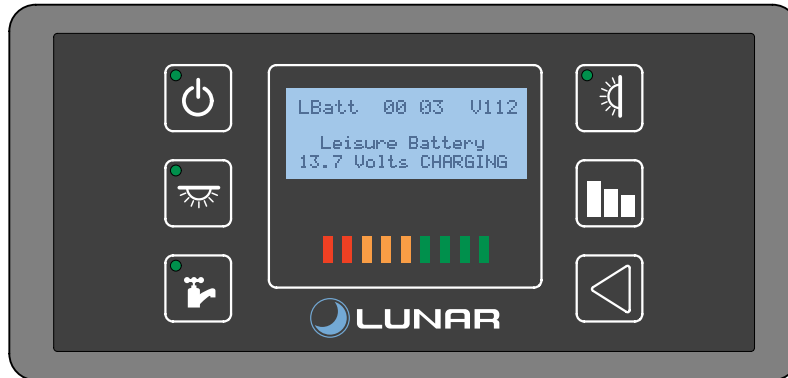



EC360 Digital Control Panel (LCD graphic display)





ELECTRICS

2.6 Control Panel Operation

Button	Button Description
	Power Button. Press the power button to turn the leisure power on. Press the button again to turn the power off. The adjacent LED will illuminate when the power is on, and also the voltage of the selected battery will be displayed on the screen. When the car engine is running this LED will flash to indicate the leisure battery is being charged.
	Pump Button. With the power on, press the pump button to turn the water pump on. Press the button again to turn the pump off. The adjacent LED will illuminate when the pump is on, and also the level of the water tank will be displayed on the screen (if the optional onboard water tank is fitted).
	Light Button. With the power on, press the light button to turn the main internal lighting on. Press the button again to turn the lights off. The adjacent LED will illuminate when the lights are on. The lights will be turned on and off automatically each time the power button is operated.
	Awning Light Button. With the power on, press the awning light button to turn the awning light on or off. The adjacent LED will illuminate when the light is on.
	Levels / scroll button. Use this button to scroll through the various levels screens / menu items or to cancel alarms / warnings. Note: The screen illumination / backlight will turn off after a period of time. Press the levels button or wave your hand in front of the illumination sensor to reactivate the illumination.
	Select button. Use this button to select options/items or to change settings.



3 System Technical Information

The following section provides further technical information relating to the electrical system.

3.1 Residual Current Device & Miniature Circuit Breakers

The Residual Current Device (RCD) is basically provided to protect the user from lethal electric shock. The RCD will turn off (trip) if the current flowing in the live conductor does not fully return down the neutral conductor, i.e. some current is passing through a person down to earth or through a faulty appliance.

To ensure the RCD is working correctly, the test button should be operated each time the vehicle is connected to the mains supply (see section 2.3)

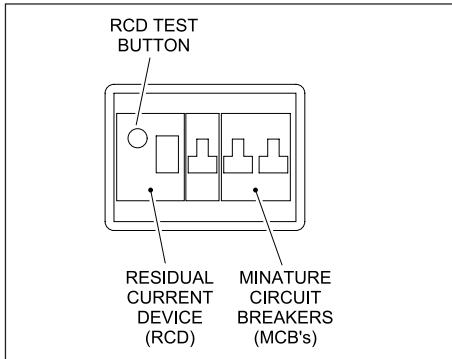

The Miniature Circuit Breakers (MCB's) operate in a similar way to traditional fuses and are provided to protect the wiring installation from overload or short circuit. If an overload occurs the MCB will switch off the supply. If this occurs you should investigate the cause of the fault before switching the MCB back on.

MCB	Rating	Description (cable colour)
1	10 Amps	230v Sockets (white)
2	16 Amps	Combination water heater / central heating system (yellow) Extra 230V sockets (white)
3	10 Amps	Fridge (black) 12V Charger (internally socketed)

3.2 Battery Charger

The EC175PSU incorporates a fixed voltage battery charger / power converter. The battery charger / power converter also powers the leisure equipment when the mains supply is connected. This module supplies 13.8V DC to the leisure equipment up to a maximum of 12 Amps (155 Watts), therefore the available power is distributed between the leisure load and the battery, with the leisure load taking priority as per the following example:

The table below shows the rating and circuit allocation for the three MCB's

Leisure load	Available power for battery charging
3A	9A
6A	6A
9A	3A
12A	0A

WARNING

Under heavy loads the power supply unit case may become hot. ALWAYS ensure the ventilation slots have a clear flow of air. Do not place combustible materials against / adjacent to the EC175. The PSU will shutdown if overheated and will restart automatically when cool.



ELECTRICS

3.3 Leisure Battery

3.3.1 Type / Selection

For optimum performance and safety it is essential that only a proprietary brand LEISURE battery is used with a typical capacity of 75 to 120 Ah (Ampere / hours). A normal vehicle battery is NOT suitable. This battery should always be connected when the system is in use.

The PSU is configured to work with standard lead acid leisure batteries, and in most cases is also compatible with the latest range of Absorbed Glass Matt (AGM) batteries. Before fitting non-standard batteries please check that the charging profile described in 3.2 is suitable for the type of battery by referring to the battery documentation or battery manufacturer.

The battery feed is fitted with an inline fuse between the battery and the electrical harness, and is usually located immediately outside the battery compartment or within 500mm of the battery. The maximum rating of this fuse is 20A.

3.3.2 Installation & Removal

Always disconnect the 230v mains supply and turn the PSU green charger switch to the off position (button out) before removing or installing the battery.

When connecting the battery, ensure that the correct polarity is observed (black is negative

[-] and red is positive [+]) and that the terminals are securely fastened. Crocodile clips must not be used.

WARNING: Explosive gases may be present at the battery. Take care to prevent flames and sparks in the vicinity of the battery and do not smoke.

3.3.3 Operation / Servicing

Under normal circumstances it should not be necessary to remove the battery other than for routine inspection of the terminals and “topping up” of the battery fluid where applicable. Please see instructions supplied with the battery.

Note: Do not over discharge the battery. One of the most common causes of battery failure is when the battery is discharged below the recommended level of approximately 10v. Discharging a battery below this figure can cause permanent damage to one or more of the cells within the battery.

To prevent over discharge, the EC175 system incorporates a battery protect circuit that warns the users and then disconnects the batteries when they fall below set values.

3.4 Generator Usage

Caution should be used before connecting a generator to your caravan.

WARNING: Never start or stop the generator while electrical loads are connected and switched on. Start the engine, let it stabilise and then connect the electrical load. To stop the engine, disconnect the electrical load and let engine stabilise before switching off.

Whilst some generators use electronic inverter technology, others use a more basic principle to generate the 230V supply. Preference should be to choose a generator which produces a consistent sinusoidal wave form with accurate voltage control.

The Reverse Polarity warning light on the PSU may illuminate when using a Generator. This is a normal side effect when using some types of generator. Instead of connecting the neutral conductor to earth, some generators centre tap the earth connection making both neutral and live conductors 110V above earth. This 110V difference causes the neon polarity indicator to illuminate.

In most cases it is safe to use a generator, but please consult the generator handbook for further information.

3.5 Awning Light Operation

The awning light is controlled by the control panel awning light button. On some models the awning light is also linked to the optional alarm system to enable remote control with the alarm fob.



3.6 System Warnings

The system incorporates a number of warnings that are active at specific times. These are summarised below, and also covered by relevant sections of this manual.

Warning	When	Type
Fresh water level low	With pump turned on and fresh water level low (less than 25% full) Only available when an onboard tank is fitted	Message on screen and 30 second audible beep.
Leisure battery voltage low	With control panel power on and leisure battery selected (as active battery) and the voltage level falls below 10V.	Message on screen (or flashing LED bar graph on EC350) and 30 second audible beep.
	With control panel power on and leisure battery selected (as active battery) and the voltage level falls below 9V.	Message on screen (or flashing LED bar graph on EC350) and 30 second audible beep. If no action taken after 30 seconds then the system will switch the power of to prevent severe discharge of the battery
<p>Note: This is an emergency cut off level to protect the battery from severe damage. You should not rely on this cut off level during normal operation, but manage your power consumption to a discharge level of 11.5V or above.</p> <p>This cut off only applies to power drawn from the battery by the leisure equipment that is controlled by the control panel power switch; it will not protect the battery from discharge by permanently connected equipment.</p>		
Leisure battery voltage high	With control panel power on or off and leisure battery is selected (as active battery) and the voltage level rises above 15.4V	Message on screen (or flashing LED bar graph on EC350) and repeated beeps from the control panel. The beeping will not stop until the fault is cleared.
Vehicle battery warnings	If the vehicle battery is selected instead of the leisure battery, then the same warnings described above for the leisure battery are applied to the vehicle battery.	
Engine running	When the engine is started the system power will be turned off	Message on screen (EC360 only) and power button LED flashing indicating both batteries are connected for charging.



ELECTRICS

3.7 12 Volt DC Fuses

WARNING: When replacing fuses always replace a fuse with the correct value. NEVER replace with a higher value/rating as this could damage the wiring harness. If a replacement fuse 'blows' do not keep replacing the fuse as you could damage the wiring harness. Please investigate the fault and contact your dealer.

The table opposite shows the fuse allocation for the 12 fuses fitted to the PSU. Please note that fuses are dependant on PSU versions, so not all fuses may be present or used.

Fuse	Rating	Fuse Colour	Description
1	10 Amps	Red	Water Pumps / Toilet
2	2 Amps	Grey	Permanent Supplies / Electronics
3	5 Amps	Tan	Heater Fans
4	10 Amps	Red	Lights
5	15 Amps	Blue	Fridge Element (during towing)
6	10 Amps	Red	Extractor fans
7	5 Amps	Tan	Ignitions
8	10 Amps	Red	Switched Lights
9	20 Amps	Yellow	Vehicle Battery
10	20 Amps	Yellow	Leisure Battery
11	10 Amps	Red	12V Sockets
12	15 Amps	Blue	Charger

The following table shows details of the fuse(s) located at the Leisure battery.

Fuse	Rating	Fuse Colour	Description
Battery 1	20 Amps	Yellow	Fuse remotely located near battery



3.8 Common Fault Table

Fault	Possible Cause	Proposed Fix
No 230 volt output from PSU	Connecting lead between the site and Leisure Vehicle not connected	Check and connect lead as per 2.3C
	RCD switched off	Reset RCD as per 2.3D
	RCD not operating correctly	Check supply polarity; if the RCD continues to fail contact your Dealer as there is probably an equipment or wiring fault
	MCB switched off	Reset MCB by switching OFF (down position) then back ON (up position), if the MCB continues to fail contact your Dealer as there is probably an equipment or wiring fault
	No or deficient supply from site	Contact site Warden for assistance
	Other fault	Contact your Dealer.
Control Panel problems	Control panel has no display	Backlight/illumination may have switched off. Press the power button or select button to reactivate the backlight. Check batteries and fuses, turn PSU shutdown switch and charger switch on and ensure mains supply is connected. Check control panel connecting lead at PSU and behind Control Panel. Contact your Dealer
	12v Power turns off	Battery protect feature has operated to protect the Vehicle battery and or the Leisure battery. See 3.6 Engine has been started, all equipment has been disconnected to meet EMC requirements. See 2.4
	Control panel locked/erratic function	Observe control panel handling instructions. Control panel software may have crashed. Reboot control panel by turning off the PSU isolate switch. Wait 30 seconds then turn the switch back on.
No 12 volt output from PSU	No 230V supply	Check all above.
	Charger not switched on	Turn charger switch on, switch will illuminate
	Battery not connected and / or charged	Install charged battery as per 3.3.
	Power button on control panel not switched on	Turn power on at control panel
	Battery flat / Battery fuse blown	Recharge battery, check fuses, check charging voltage is present at battery.
	Fuse blown	Check all fuses are intact and the correct value fuse is installed as per fuse table
	Equipment switched off / unplugged	Check equipment is switched on and connected to the 12V supply.



ELECTRICS

3.9 Common Fault Table (continued)

Fault	Possible Cause	Proposed Fix
	PSU overheated / auto shutdown operated	Reduce load on system. Allow PSU to cool down. PSU will automatically restart when cool.
	Other fault	Contact your Dealer.
	Fuse blown	Replace fuse with correct value as per fuse table.
	Pump turned off	Turn pump on by pressing the pump button at the control panel.
Pump not working	Setting incorrect	Both the internal and external pump feeds are controlled from the control panel. To alter the setting of the pump switch see your dealer. Ensure the setting matches your desired requirement.

3.11 Contact details

Sargent Electrical Services Limited, provide a technical help line during office hours. Please contact 01482 678981 if you require technical help. For out of hour support please refer to the tech support section of the Sargent web site www.sargentltd.co.uk.

4 EC360 Control Panel

In addition to the information contained in section 2.5 (Control Panel Operation), the following section provides further detail information.

4.1 Screen Illumination Operation

The screen illumination (backlight) is turned on and off automatically. Pressing the levels button will reactivate the illumination.

4.2 Header Area



The header area of the screen shows the following information;

LBatt or VBatt	Leisure battery selected. This symbol indicates that the leisure battery is selected as the battery to use or to charge. This is the default setting. Vehicle battery selected. This symbol indicates that the vehicle battery is selected as the battery to use or to charge. This is only available when the car is connected and the vehicle battery has been selected.
13 : 45	Clock display. This shows the current time in a 24 hour format.
V112	This shows the software version of the control panel.



4.3 LED Bar Graph



The LED Bar Graph displays the voltage of the selected battery.

1	Red		<9.5 (<9 LED Flashes)
2	Red		9.5 - 10.9
3	Amber		11 - 11.4
4	Amber		11.5 - 11.9
5	Amber		12.0 - 12.4
6	Green		12.5 - 12.9
7	Green		13.0 - 13.4
8	Green		13.5 - 13.9
9	Green		14.0 - 14.4 (>15.4 LED Flashes)

When the control panel power is on, pressing the levels  button will display the battery voltage on the bar graph.





ELECTRICS

4.4 Information Area







The main information area can display a variety of system information screens. These have been designed to present the information in a clear and concise form, while retaining technical detail for the more advanced users.

The selected screen can be changed by using the levels / scroll button and work on a continuous loop basis (when the last screen is reached the scrolling returns to the first). The selected screen may be changed automatically by the system depending on the action being performed.

1 - Leisure Battery	<p>Leisure Battery 13.9V GOOD</p>	<p>Here leisure battery information is shown.</p> <p>The digit display shows the battery voltage followed by a guide to the battery charge condition (i.e <i>POOR, FAIR, GOOD, CHARGING</i>).</p> <p>The voltage is also shown on the LED bar graph below the display.</p> <p>Pressing the levels  button to move to the next screen.</p>
2 - Vehicle Battery	<p>Vehicle Battery 12.2V FAIR</p>	<p>Here, if the tow car is connected, the vehicle battery information is shown similar to the leisure battery (see above).</p> <p>The voltage is also shown on the LED bar graph below the display.</p> <p>Pressing the levels  button to move to the next screen.</p>
3 - Water Tank	<p>Fresh Water Level 25%</p>	<p>The 3rd screen shows information relating to optional onboard water tank. This screen is only available when the tank is fitted.</p> <p>The tank water level is shown in + steps (i.e. 0%, 25%, 50%, 75% & 100%)</p> <p>The displayed level is continuously refreshed if the water pump is turned on.</p> <p>Pressing the levels  button to move to the next screen.</p>



4.4 Information Area (continued)

4 - Select Battery	<p>Select Battery Battery = LEISURE</p>	<p>Here you can select which battery to use or charge.</p> <p>By default the leisure battery is automatically selected. If the mains supply is connected and the charger turned on, this battery will also be charged.</p> <p>If you need to select the vehicle battery, and the tow car is connected, press the select  button to change the selected battery from leisure to vehicle (or vice versa).</p> <p>The relevant symbol (LBatt) or (VBatt) will be shown in the header area.</p> <p>Information relating to the selected battery is shown on the screen.</p> <p>Pressing the levels  button to move to the next screen.</p>
7 - Adjust Hour	<p>Adjust Hour Hour = 13</p>	<p>Here you can adjust the hour display.</p> <p>Press the select  button to increase the value by 1. Press and hold the button to rapidly increase the value.</p> <p>Pressing the levels  button to move to the next screen.</p>
8 - Adjust Minute	<p>Adjust Minute Minute = 13</p>	<p>Here you can adjust the minute display.</p> <p>Press the select  button to increase the value by 1. Press and hold the button to rapidly increase the value.</p> <p>Pressing the levels  button to move to the next screen.</p>
9 - System Info	<p>SARGENT EC360 LCD Control Panel</p>	<p>Here you can view the control panel model number (i.e. <i>EC360</i>). Note that the software version number is also shown in the top right.</p> <p>Pressing the levels  button to move to the first screen.</p>

The system can display a number of warnings. The control panel will beep and display the appropriate message. Press the levels  button to cancel the warning. See 3.6 for further details.



ELECTRICS

5 TECHNICAL DATA & APPROVALS

5.1 Outline specification - EC175PSU & EC350/360 Control Panel

INPUT 230V	230 Volts / 0 to 16 Amps	+ / - 10%
OUTPUT 230V	RCD protected, 3 x MCB outputs of 1 x 16A and 2 x 10A Separate switched channels for water heater, space heater and charger	
INPUT 12V	2 x 20A battery inputs via 2 x 4 way connectors	
OUTPUT 12V	25A total output via multiple switched channels protected by 12 fused outputs	
Built in CHARGER	Input 220-240 Volts AC +/- 10%, Frequency 50 Hz +/- 6%, Current 3A max. DC Output 13.8 Volts nominal, Current 12 Amps max (155 Watts)	
Signal INPUT	4 x Fresh water level, 1 x Engine running, plus multiple vehicle connections	Fresh water negative sensed
Data IN / OUT	Data communication and power to Control Panel via 8 way connector	
IP rating	IP31	
Operating temperature	Ambient 0 to 35° Centigrade PSU case temperature with full load 65°C Max	Automatic shutdown and restart if overheated/overloaded
EC175 PSU	Overall size (HxWxD) 260 x 273 x 110mm Clearances 75mm above, 20mm below, 50mm left & right	Fixing centres 262 x 224mm Weight 2.2kg
EC350 & EC360 Control Panel	Overall size (HxWxD) 95 x 200 x 25mm Cut-out size (HxW) 82 x 178mm	Fixing centres 190mm Weight 180g



CLUBMAN/DELTA ADDITIONAL LIGHTS

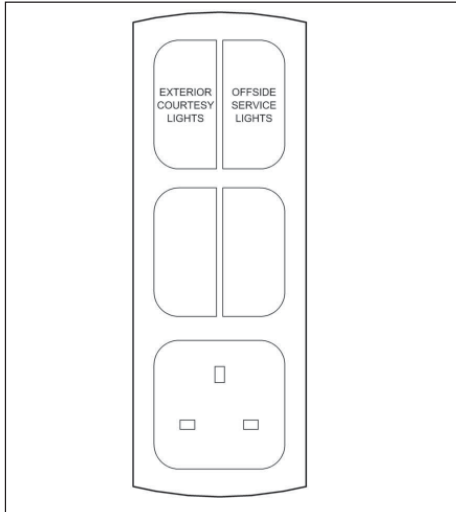

The Clubman and Delta ranges feature an offside service light as well as exterior courtesy lights.

Offside Service Light Switch: Activates/deactivates the external service light situated on the offside of the caravan.

Exterior Courtesy Light Switch: Activates/deactivates the courtesy lights on the front and rear grab handles.

GENERAL INFORMATION

BATTERY

For optimum performance and safety it is essential that only a good quality CARAVAN battery is used. A normal car battery is NOT suitable.

WARNING

One of the most common causes of caravan battery failure is for the battery to be discharged below the recommended level of approximately 10.5 Volts and therefore causing one or more cells to fail.

Provided the appropriate relay is fitted to your car and the connection is made via the 13 pin plug and socket, a small trickle charge is achieved from car battery to the leisure battery when towing.

The auxiliary battery compartment is located on the offside of the caravan, with easy to fit and clearly identified positive and negative connectors.

It is recommended that a good quality leisure battery is always in circuit when the system is in use.

A heavy duty 12v battery should be purchased to provide power for lights and other electrical appliances. A proprietary brand leisure battery with a 60, 90 or 110

amp capacity is recommended. (It must have tube venting capability for internal battery boxes).

It should be remembered that batteries suitable for the electrical demands of a caravan differ in design from those for use with a car, and whilst the system may operate with a car battery it is strongly recommended that only a caravan/leisure type battery, maintained in good condition is used. The battery should be kept topped up at all times.

The battery should be positioned in the designated vented compartment and properly secured. When connecting the battery, ensure that the correct polarity is observed (black is negative and red is positive) and that the terminals are securely fastened. (Crocodile clips are not recommended.)

Under normal circumstances it should not be necessary to remove the battery other than for routine inspection of terminals and "topping up".

The AC output of generators is often derived from an AC alternator, rectified to DC then inverted back to AC. In essence this means the output sinewave may not be very smooth and may not run sophisticated electronics efficiently. Some of the new wave of gensets are more sophisticated in their production of



ELECTRICS

a sinewave output and are more suited to run electronic equipment.

If in doubt consult your genset dealer or manufacturer for advice.

WARNING

Explosive gases may be present at the battery. Take care to prevent flames and sparks in the vicinity.

WARNING

Switch off all appliances and lamps before disconnecting the battery.

GENERATOR GUIDELINES

Lack of regular servicing can be the cause of most generator problems. Gensets under 2kW are mainly dependent on engine speed for output frequency and voltage, poor or no servicing may cause the engine speed governor to run the genset engine too fast. Therefore frequency and output voltage can rise above the specification of the machine data plate, i.e. 240v at 50Hz, This may cause damage to electrical/electronic equipment (such as battery chargers).

A generator should always be run for a few minutes prior to connection with the caravan electrics, to allow it to warm up and the output to settle to a steady level.

SUPPORT SERVICE

Contact your local dealer.



FITTED EQUIPMENT

Refrigerators	84
Dometic RMS8500 Fridge	84
Dometic RMS8551 Fridge	84
Dometic RMD8551 Fridge Freezer	91
Oven, Hob & Grill	94
Microwave	98
Truma Combi	99
Alde Heating	103
Thetford C-260 Toilet	108
Dometic Toilet CTW4050	116
Awning Points	122
Rooflight	122
TV Antenna	123
CD/Radio/MP3	126
Alarm	127
Flyscreens/Blinds	128
Window Care	130
Condensation	130
ABS Panels	132
Badges	132
Bunk Beds	133
How to Maintain Furniture in a Caravan	135



REFRIGERATOR

Note: Most proprietary items within the caravan will have their own instruction book, the information within the Lunar Handbook is an extract of the most relevant aspects.

IMPORTANT: In the interest of safety, replacement parts for an appliance shall conform to the appliance manufacturer's specifications and should be fitted by them or an authorised agent.

To maximise the use and life of all fitted equipment in your caravan it is essential that any accompanying manufacturers' literature is read fully. All recommended maintenance and preparation procedures should be followed. The information provided in this handbook is only intended as a guide. If in any doubt consult your Lunar appointed dealer, particularly before attempting to install EXTRA EQUIPMENT.

REFRIGERATORS

Winter Operation - Dometic Refrigerators



▲ Please check that the ventilation grilles or the flue outlets are not blocked by snow, leaves etc.

MODEL RMS 8500 (Ariva Only)
MODEL RMS 8551 Clubman, Lexon, Quasar, Stellar (single axle Lexon only)

Cleaning

Before starting up the refrigerator, it is recommended to clean it inside and repeat

this at regular intervals. Use a soft cloth and lukewarm water with a mild detergent. Then wipe out the appliance with clean water and dry thoroughly.



▲ To avoid deterioration of materials: Do not use soap or hard, abrasive or soda-based cleaning agents. Do not allow the door seal to come into contact with oil or grease.

Operating modes and use of the refrigerator

- This refrigerator is equipped to operate on three power modes: AC mains power (230V), 12V DC or gas (propane/butane liquid gas).
- Select the desired power mode by the energy selector switch (battery igniter

type models) or the MODE button (MES, AES). Appliances with automatic energy selection (AES) are additionally provided with automatic mode function. The AES system automatically selects the best energy source for each particular situation.

- The cooling unit is silent in operation.
- The refrigerator works reliably on slopes of up to 6 degrees (5 degrees with models starting from 140 litres capacity).
- When the appliance is started for the first time, there may be a mild odour which will disappear after a few hours. Air the living space thoroughly.
- The refrigerator will take several hours to reach its operating temperature in the cooling compartment.

Control elements of energy selections (BATTERY IGNITER, MES and AES)

Manual energy selection/manual ignition (RMS 8500) battery igniter:

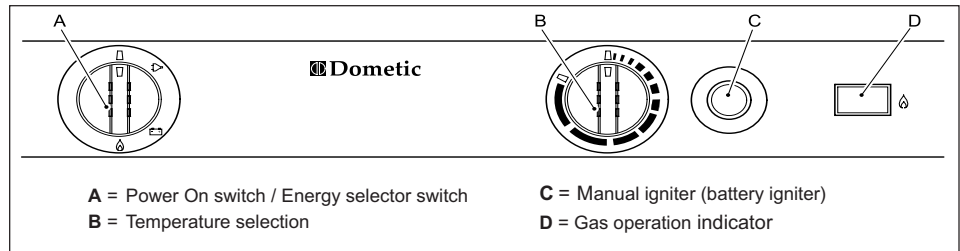



Explanation:

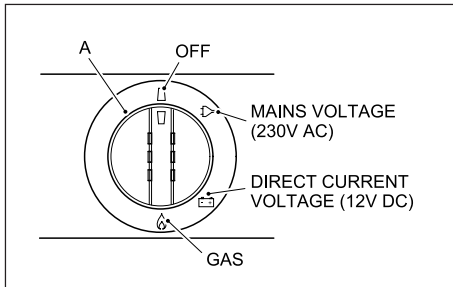

The refrigerator is equipped to operate on mains power, 12V DC or liquid gas. Select the desired power supply by turning the energy selector switch A. The energy selector switch A has four settings: OFF, AC mains voltage, DC (battery), gas (liquid gas).



Electrical operation

Appliances with battery igniter (manual energy selection)

Switch on the appliance by turning the energy selection switch A clockwise to position:

-  230V operation,
-  12V operation

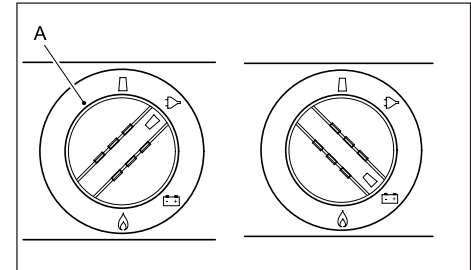

- In order to prevent discharge of the on-board battery, 12V operation should only be used while the motor is running.

Gas operation (liquid gas)



- ▲ The refrigerator must be operated using liquid gas (propane, butane (no natural gas or town gas). When using LPG gas, please consider that the burner needs cleaning at shorter intervals due to the gas combustion method (semi-annual recommended).
- ▲ In Europe, gas operation is permitted while travelling only on the condition that the gas system of the vehicle is equipped with a hose rupture protection. The national regulations of the respective country must be observed.
- ▲ For physical reasons, ignition faults could occur starting from an altitude above sea level of approx. 1000m/3280 ft. (No malfunction!)
- ▲ On the initial refrigerator start-up or after a cylinder change, air may be trapped in the gas line. To purge the air from the lines, switch on the refrigerator and any other gas appliances (e.g. stove) for a short time. The gas ignites without delay.
- ▲ As a basic rule, gas operation is prohibited in petrol stations.



REFRIGERATOR

Prior to starting the refrigerator in gas mode:

- Open the gas cylinder valve.
- Open the shut-off valve for gas supply to the refrigerator.

Appliances with battery igniter:

1. Turn the rotary selector switch **A** to position .
2. Turn the temperature selector **B** clockwise and push. Keep the controller button depressed.
3. Then, press knob C of battery igniter down and keep it depressed. The ignition process is activated automatically.
4. Once the flame ignites, the pointer of galvanometer **D** begins moving into the green range. The refrigerator is operational. Keep knob **B** depressed for approx. 15 seconds and finally release it.

Each refrigerator with manual ignition is equipped with an automatic flame safety valve which interrupts the gas supply after approx. 30 seconds when the flame has extinguished.

Door Locking

Open the door by pressing the locking button and pull open.

Shut the door again by pushing it to close. The snapping into the lock can be heard.

While the vehicle is parked, the locking hook may be fixed to facilitate opening of the door.

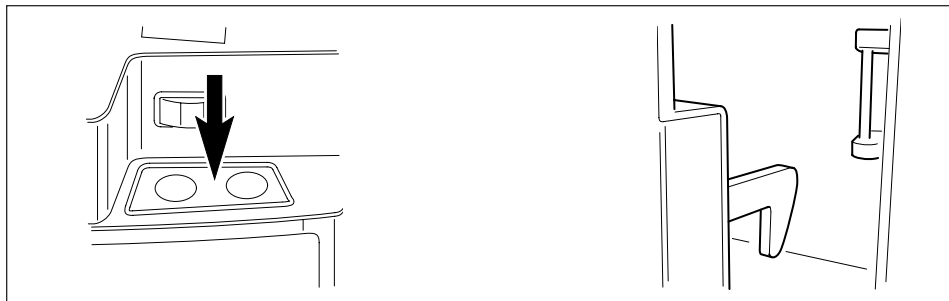
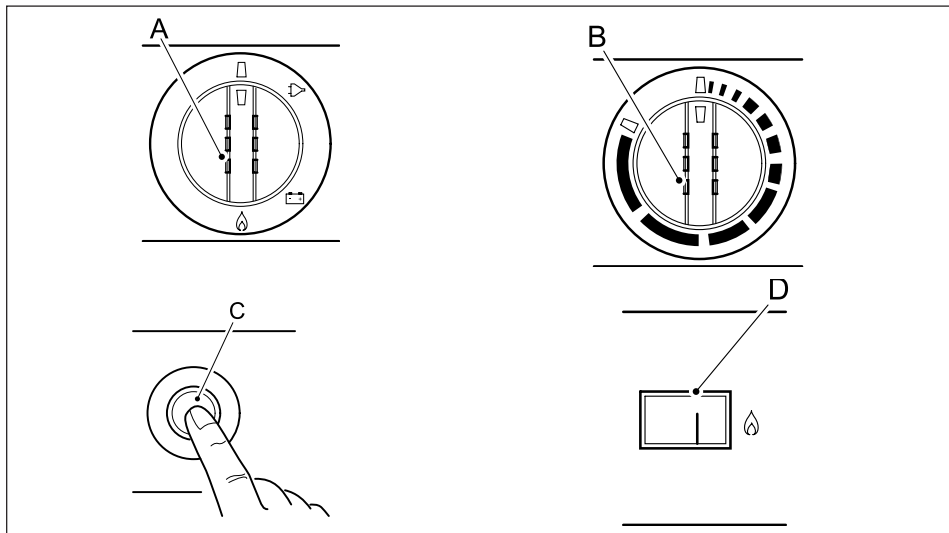



Fixing and releasing the door lock hook when parking the vehicle

If the vehicle is parked for a longer period of time, the locking hook may be clamped by means of a lockbar. The door may now be opened by just pulling it without need of pressing the locking button.

Restore the original position by pushing the hook down.



▲ As a basic rule, shut and lock the refrigerator door before commencing your journey.

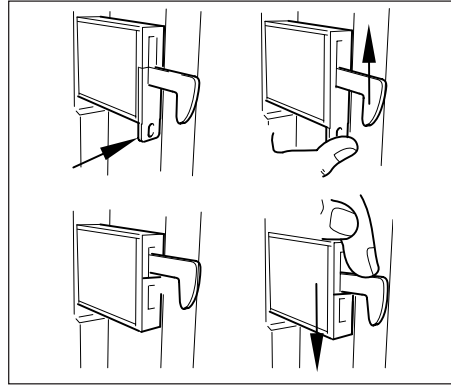

Removable freezer compartment

To enlarge the cooling space, just remove the freezer compartment.

Unlock the freezer compartment on both sides and pull it out.

Store the freezer compartment safely in order to prevent damage.

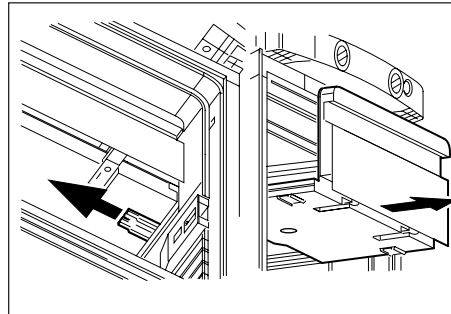

Positioning the storage racks

The storage racks may be pulled out by smoothly lifting them and may be positioned as desired.

- ▲ Once the freezer compartment is removed, an additional storage rack may be installed. The storage rack is a piece of extra equipment and may be obtained from Dometic.

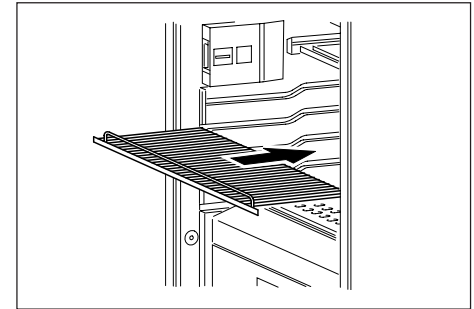



REFRIGERATOR

Exchange of the igniter's battery

Unlock the battery by depressing and turning the button (C) approximately 90 degrees clockwise.

Remove cap and exchange battery (1.5V AAA / R3 / Micro). Observe correct polarity.

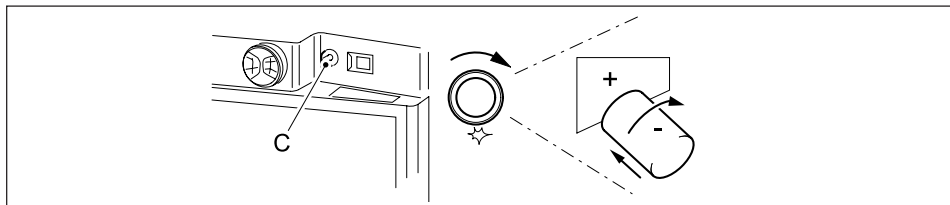

Shutting off the refrigerator

- For battery igniter models, set energy selector switch **A** to position 'OFF'. The appliance is switched off.
- Press the 'MODE' button to switch off MES and AES models. Keep button **A** pressed for two seconds. The display disappears and the appliance is fully switched off.
- Release the locking mechanism of the door lock by pushing it and shift it to the front. If the door is shut in this position, a small gap is nevertheless kept open to prevent formation of mildew.
- If the refrigerator is to be taken out of service for an extended period of time, close the onboard shut-off valve and the cylinder valve.

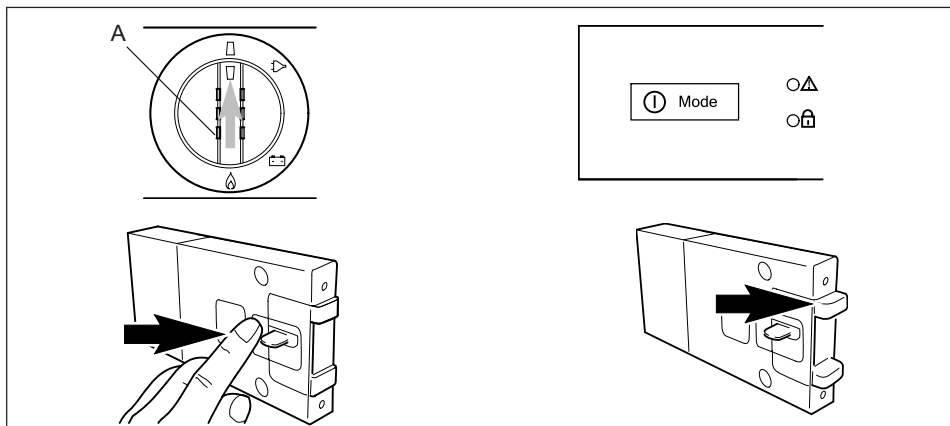

Lighting

If the door is open for more than two minutes, the sensor-controlled interior lighting is automatically cut off (except for models with battery igniter).

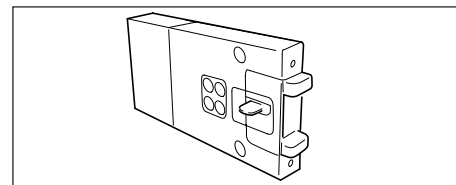



Troubleshooting

Before notifying the authorised Service Centre, please check whether:

- ▲ The instructions in the section “Operating the refrigerator” have been followed.
- ▲ The refrigerator is level.
- ▲ It is possible to operate the refrigerator with any available power source.

Failure: The refrigerator does not cool sufficiently.

Possible cause

- a) Inadequate ventilation to the unit.
- b) Thermostat setting is too low.
- c) The condenser is heavily frosted.
- d) Too much warm food has been stored inside within short period of time.
- e) The appliance has been running for only a short period of time.
- f) Ambient temperatures too high.

Action you can take

- a) Check that the ventilation grilles are not covered.
- b) Set thermostat to a higher level.
- c) Check that the refrigerator door closes properly.
- d) Allow warm food to cool down before storage.
- e) Check whether the cooling compartment works after approximately 4-5 hours.
- f) Regularly remove ventilation grilles.

Failure: The refrigerator does not cool in gas operation mode.

Possible cause

- a) Gas cylinder empty.
- b) Is the supply shut-off device open?
- c) Air in the gas pipe?

Action you can take

- a) Change gas cylinder..
- b) Open the shut-off device.
- c) Switch off the appliance and start again. Repeat this procedure 3-4 times, if necessary.



REFRIGERATOR

Failure: The refrigerator does not cool in 12V operation.

Possible cause

- a) On-board fuse defective.
- b) On-board battery discharged.
- c) Engine not running.
- d) Heating element defective (please also refer to failure indication).

Action you can take

- a) Fit new fuse.
- b) Check battery, charge it.
- c) Start engine.
- d) Please inform the Dometic Customer Services.

Failure: The refrigerator does not cool in 230V operation.

Possible cause

- a) On-board fuse defective.
- b) No connection to supply voltage.
- c) AES: gas operation despite connection to the supply voltage?
- d) Heating element defective (please also refer to failure indication).

Action you can take

- a) Fit new fuse.
- b) Establish power connection.
- c) Appliance switches to gas operation due to insufficient supply voltage (automatically switches back to 230V operation).
- d) Please inform Dometic Customer Services.

Maintenance

- Works on gas components and electrical installation may only be carried out by authorised personnel. We recommend to contact your Dometic Service Centre.
- EN 1949 stipulates that the appliance's gas equipment and its associated fume system must be inspected after installation and a certificate issued.
- Afterwards a qualified technician must inspect according to EN 1949 every two years and a certificate issued.



FRIDGE FREEZER (Model RMD8551) Delta, Lexon (Twin Axle Only)

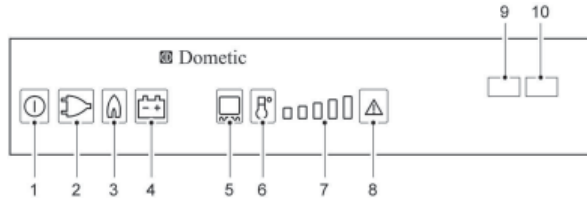

- | | |
|-------------------------------|--|
| 1 Power ON/OFF switch | 6 Temperature level selection |
| 2 Energy selector button 230V | 7 Temperature level display |
| 3 Energy selector button GAS | 8 Indicator LED failure/Reset button GAS FAILURE |
| 4 Energy selector button 12V | 9 LED "failure" (red) |
| 5 Frameheating | 10 LED "operational" (blue) |

Cleaning

Before starting up the refrigerator, it is recommended that you clean it inside and repeat this at regular intervals.

Use a soft cloth and lukewarm water with a mild detergent. Then wipe out the appliance with clean water and dry thoroughly.

Operation

The control panel buttons are not accessible when the refrigerator door is closed. Open the bottom door to reach the operating buttons.

There are two LEDs on the right edge of the control panel. The outer LED (10) indicates

that the refrigerator is operational (blue). The other LED (9) lights red in the event of a fault.

The refrigerator is equipped to operate on mains power, 12V DC or liquid gas.

Switch the refrigerator ON or OFF by pressing button 1 for 2 seconds. The refrigerator starts with the last selected type of energy.

MES Appliances (manual energy selection)

Select the desired power supply by the energy selector buttons 2, 3 and 4. Then set temperature step by pressing button 7.

Gas Operation (Liquid gas)

- The refrigerator must be operated using liquid gas (propane, butane) (no natural gas or town gas). When using LPG gas, please consider that the burner needs cleaning at shorter intervals due to the gas combustion method (2-3 times per year recommended)
- In Europe, gas operation is permitted while travelling only on the condition that the gas system of the vehicle is equipped with a hose rupture protection. The national regulations of the respective country must be observed.
- For physical reasons, gas ignition faults could occur starting from an altitude above sea level of approx. 3280 ft / 1000m (No malfunction!)
- On the initial refrigerator start-up or after a cylinder charge, air may be trapped in the gas line. To purge the air from the lines, switch on the refrigerator and any other gas appliances (e.g. stove) for a short time. The gas ignites without delay.



▲ As a basic rule, gas operation is prohibited in petrol stations.

Prior to starting the refrigerator in gas mode:

- Open the gas cylinder valve.
- Open the shut-off valve for gas supply to the refrigerator.



REFRIGERATOR

Gas Operation

Press button **3**. The ignition process is activated automatically by means of an automatic igniter.

The flame extinguishes after reaching the preset cooling compartment temperature and ignites again if the cooling compartment temperature increases again. If the flame is not lit after the first ignition attempt, the automatic igniter repeats the ignition twice (duration 30s) at time intervals of 2 minutes. If the flame is not lit afterwards, a fault is indicated.

Additional Features

The brightness of the display reduces after a few seconds if no other buttons are pressed. The indicator lights again if a button is pressed. Press the button again to activate the required function.

Failures are indicated by flashing of the failure indicator LED.

Should the door be kept open for too long (more than 2 minutes), an acoustic signal is initiated (pulsing whistle tone).

Frame heating

All models are equipped with a frame heating (12VDC/3,5W) around the freezer compartment. During summer months with high temperatures and humidity the metal frame may have water droplets forming. To evaporate these droplets switch on the frame heating with button **5**.

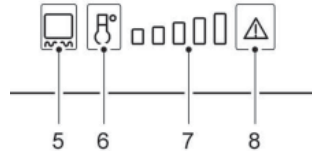

The operating time of the frame heater can be set to 2 hours, 5 hours or continuous operation. After selecting the operating time using button **(5)**, the temperature level indicator **(7)** is extinguished for a short time to show the set operating time for a few seconds. The display then returns to the temperature level indicator.

Shutting off the refrigerator

Switch off the refrigerator by pressing button **1**. Keep button **1** pressed for 3 seconds. The display disappears and the appliance is fully switched off.

Defrosting

As time goes by, frost builds up on the fins inside the refrigerator. A layer of frost thicker on one side may occur and does not represent a malfunction. When this layer of frost is about 3mm thick, the refrigerator should be defrosted.

- Switch off refrigerator.
- Remove all food and the ice cube tray.
- Leave the refrigerator door open to allow air to enter and to prevent formation of mildew.
- After defrosting (freezer compartment and fins free of frost), wipe both cooling compartments dry with a cloth.

Note: Water thawing in the main compartment of the refrigerator runs into an appropriate container at the back of the refrigerator. From there the water evaporates.



The layer of ice must never be removed forcibly, nor may defrosting be accelerated using a heat source!



Troubleshooting

If a malfunction occurs, the indicator LED Failure 4 flashes and LED 9 simultaneously.

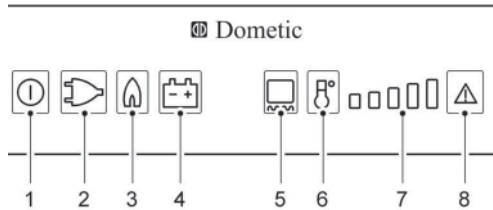

Display:	Failure:
Flashing + acoustic signal	230V mode: "230V" not available or voltage too low
Flashing + acoustic signal	12V mode: "12V" not available or voltage too low
Flashing + acoustic signal	GAS/Auto mode: Flame not ignited.
Flashing	Temperature sensor without contact or defective
Flashing	230V mode: Heating element defective
Flashing	12V mode - Heating element defective
Flashing	Burner defective or cooling unit defective



OVEN, HOB & GRILL

ASPIRE DUEL FUEL OVEN

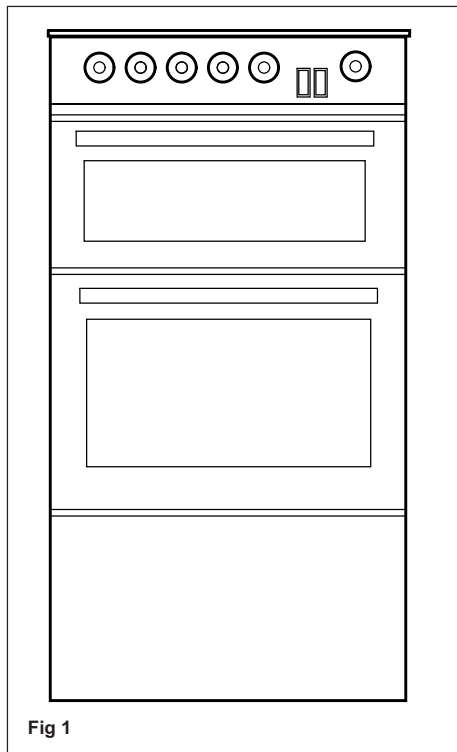

Fig 1

OPERATION

Hotplate burners

Ensure the gas cylinder is turned on.

In the event of a gas smell turn off at the cylinder and contact supplier.

Flame supervision: each burner is controlled individually and is monitored by a thermocouple probe. In the event of the burner flames being accidentally extinguished, turn off the burner control and do not attempt to re-ignite the burner for at least one minute.

CAUTIONS:

- (1) When cooking, young children should be kept away.
- (2) Glass lids may shatter when heated. Turn off all burners and grill before shutting lid.
- (3) Spillage on the surface of the lid should be removed before opening the lid.
- (4) Do not use foil on the hob, as it creates a fire hazard.
- (5) The glass lid has a tendency to snap shut towards the end of lowering. This is caused by the travel lock action of the hinges as it is activated. Make sure all fingers are removed from appliance when closing the lid.

Operation

To light the grill, push in the control knob and turn to full rate (see Fig 2. Hold a lighted

match or taper to the burner and push the control knob in and hold. It is necessary to hold the knob depressed after the burner has ignited for approximately 10-15 seconds, to allow the thermocouple probe to reach temperature, before releasing the knob. Should the flame go out when the knob is released, the procedure should be repeated holding the knob depressed for slightly longer.

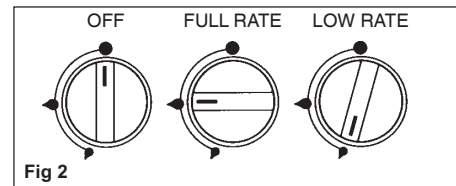

Fig 2

For models fitted with spark ignition the procedure is similar except that the burner can be ignited by depressing the ignition button, which is located on the fascia. If the burner has not lit within 15 seconds the control knob should be released and the burner left for at least one minute before a further attempt to ignite the burner.

For simmering, turn the knob further anti-clockwise to the low rate position.

To turn off: Turn the control knob until the line on the control knob is aligned with the dot on the control panel. Always make sure the control knob is in the off position when you have finished using the hotplate burners.



IMPORTANT:

- Each burner will support pans from 10 to 22 cm diameter, care should be taken not to overload the appliance as performance may be reduced.
- The following pan sizes are the maximum we recommend: electric hotplate 18cm dia, auxiliary burner 20cm dia, semi-rapid burner 2x20cm dia or 1x22cm dia with 1x18cm dia.
- When using small pans the flames should not spread beyond the base of the pan as this will reduce the efficiency of the burner.
- Avoid old or misshapen pans as these may cause instability.
- The lid must be opened fully prior to using the hotplate burners.

Using the Electric Hotplate

Ensure the electricity is switched on. The hotplate control is numbered from 1 to 6. To turn it on, rotate the knob either clockwise or anti-clockwise to the required position. Position 1 is the coolest setting. To turn off, rotate the knob until the line or pointer on the knob lines up with the zero on the control panel.

The hotplate is a sealed construction and transfers heat through conduction. For maximum efficiency a correctly sized pan with a flat heavy gauge base should be used. Pan size should be the same or slightly larger (up to 2.5cm oversize).

CAUTIONS:

Ensure the glass lid is open before turning on the hotplate burners.

WARNINGS

- Children should be supervised to ensure they do not play with the appliance.
- Glass lids may shatter when heated. Turn off the hotplate and allow it to cool before closing the glass lid.
- Remove all spillage from the surface of the glass lid before opening.
- The glass lid has a tendency to snap shut towards the end of lowering. This is caused by the travel lock action of the hinges as it is activated. Make sure all fingers are removed from appliance when closing the lid.

The grill

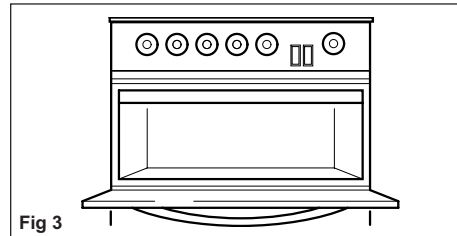

Fig 3

1. Ensure gas cylinder/supply is connected and turned on. In the event of a gas smell turn off at gas cylinder/mains and contact supplier.
2. To light: Open door, push in the control knob and turn to full rate (see Fig 2). Hold a lighted match or taper to the burner and push the control knob in and hold. The burner should ignite and the control knob should be held in for 10-15 seconds before release. If the burner goes out, repeat procedure holding control knob for slightly longer.
3. For models fitted with spark ignition the procedure is similar except that the burner can be ignited by depressing the ignition button, which is located on the fascia. Ignition must be carried out with the door open, and if the burner has not lit within 15 seconds the control knob should be released and the grill left for at least one minute before a further attempt to ignite the burner.
4. Note: The grill must only be used with the door open.
5. On first use of the grill, it should be heated for about 20 minutes to eliminate any residual factory lubricants that might impart unpleasant smells to the food being cooked. A non-toxic smoke may occur when using for the first time so open any windows and turn on mechanical ventilators to help remove the smoke.
6. Although the grill does heat up quickly, a few minutes preheat is recommended.
7. Flame Failure Device (FFD): The grill



OVEN, HOB & GRILL

burner is fitted with a flame sensing probe, which will automatically cut off the gas supply in the event of the flame going out. In the event of the burner flames being accidentally extinguished, turn off the burner control and do not attempt to re-ignite the burner for at least one minute.

- It is normal for the flames on this burner to develop yellow tips as it heats up, particularly on butane.
- A reversible grill pan trivet enables the correct grilling height to be achieved.
Fast toasting trivet in high position
Grilling sausages trivet in high position
Grilling steak/bacon trivet in high position
Grilling chops, etc. trivet in low position
Slow grilling trivet removed
- To turn off, turn the control knob until the line on the control knob is aligned with the dot on the control panel. Always make sure the control knob is in the off position when you have finished grilling.

WARNINGS:

- When the grill is being used, accessible parts may be hot, young children must be kept away.
- The grill area can get hot when the oven is in use, even if the grill is switched off.
- Care should be taken when removing parts from the grill, i.e. use of oven gloves, and by making use of the removal grill pan handle.

Notes:

- The grill pan supplied is multi functional, for use in grill or oven.
- The handle design allows removal or insertion whilst the pan is in use.
- Always remove the handle when the pan is in use,
- The grill **MUST** only be used with the door open.

The oven

CAUTIONS:

- When you are cooking, keep children away from the oven.
 - Do not use foil on the oven shelves, as this creates a fire hazard and can hinder circulation of heat.
- Ensure gas cylinder/supply is connected and turned on. In the event of a gas smell turn off at gas cylinder/mains and contact supplier.
 - To light: Open door, push in the control knob and turn to full rate (240°C). Hold a lighted match or taper to the burner and push the control knob in and hold. The burner should ignite and the control knob should be held in for 10-15 seconds before release. If the burner goes out, repeat procedure holding control knob for slightly longer.
 - For models fitted with spark ignition the procedure is similar except that the

burner can be ignited by depressing the ignition button, which is located on the fascia. Ignition must be carried out with the door open, and if the burner has not lit within 15 seconds the control knob should be released and the oven left off at least one minute before a further attempt to ignite the burner.

- Place the oven shelf in the required position and close the door. Set control knob to approximately 200°C and heat the oven for about 30 minutes to eliminate any residual factory lubricants that might impart unpleasant smells to the meals being cooked. A non-toxic smoke may occur when using for the first time so open any windows and turn on mechanical ventilators to help remove the smoke.
- Although the oven does heat up quickly, it is recommended that a 10 minute preheat be allowed. The oven should be up to full temperature in about 15-20 minutes.
- To turn off: turn the control knob until the line on the control knob is aligned with the dot on the control panel.
- Shelf: The shelf has been designed to allow good circulation at the rear of the oven and are also fitted with a raised bar to prevent trays or dishes making contact with the back of the oven. To remove a shelf, pull forward until it stops, raise at front and remove.



DO'S AND DON'TS

DO read the user instructions carefully before using the appliance for the first time.

DO allow the oven to heat fully in order to expel any smells before introducing food for the first time.

DO clean the appliance regularly.

DO provide additional ventilation, such as opening windows near grill, cooker and oven when cooking.

DO remove any spills as soon as they occur.

DO use oven gloves when removing food shelves and trays from a hot oven.

DO check the controls are in the off position when finished.

DO NOT allow children near the cooker when in use. Turn pan handles away from the front so that they cannot be caught.

DO NOT allow fats or oils to build up in the oven trays or base.

DO NOT use abrasive cleaners or powders that will scratch the surface of the hot plate and oven.

DO NOT under any circumstances use the oven as a space heater.

LEAKS

If a smell of gas becomes apparent, the supply should be turned off at the cylinder immediately.

Extinguish naked lights including cigarettes and pipes. Do not operate electrical

switches. Open all doors and windows to disperse gas escapes.

Butane/Propane gas is heavier than air and escaping gas will collect at a low level. The strong unpleasant smell of gas will enable the general area of the leak to be detected. Check that the gas is not escaping from an unlit appliance.

Never check for leaks with a naked flame; leak investigation should be carried out using a leak detector spray or soapy solution.

MAINTENANCE

This appliance needs little maintenance other than cleaning. All parts should be cleaned using warm soapy water. Do not use abrasive cleaners, steel wool or cleansing powders. When cleaning the burner ring it is essential that the holes do not become blocked. The control knobs are a push fit and can be removed for cleaning. They are interchangeable without affecting the method of operation.

THIS APPLIANCE MUST NOT BE MODIFIED OR ADJUSTED UNLESS AUTHORISED AND CARRIED OUT BY THE MANUFACTURER OR HIS REPRESENTATIVE. NO PARTS OTHER THAN THOSE SUPPLIED BY THE MANUFACTURER SHOULD BE USED ON THIS APPLIANCE.

WARNINGS:

On no account should this appliance be used as a space heater.

All pans should be mounted centrally over the burners, even when cooling, to protect adjacent walls.

Do not lower hob cover until burners and grill have cooled.

Do not store equipment in the pan cupboard so that movement whilst travelling causes them to fall against the glass door causing damage.

This appliance must not be modified or adjusted unless authorised and carried out by the manufacturer or his representative.

No parts other than those supplied by the manufacturer should be used on this appliance.

Never use a portable cooker in your tourer.

When you are cooking it is essential to provide additional ventilation, such as opening windows near grill, cooker and oven.



MICROWAVE

Microwave (Daewoo)

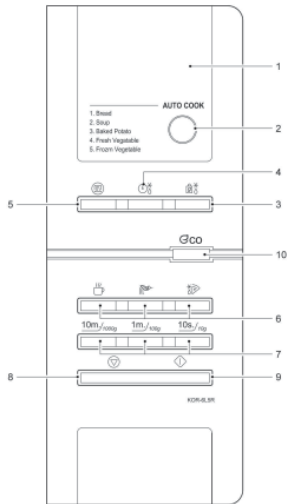

- 1 **DISPLAY** - Shows cooking time and power levels.
- 2 **AUTO COOK** - Use to cook or reheat common foods.
- 3 **WEIGHT DEFROST** - Defrost food based on weight.
- 4 **TIME DEFROST** - Defrost food by time.
- 5 **POWER** - Use to set power level.
- 6 **ONE TOUCH COOK** - Cook or reheat specific quantities of food.
- 7 **TIME SET BUTTON** - Set the cooking time and weight.
- 8 **STOP/CLEAR** - Stop the oven operation or delete the cooking data.
- 9 **START/+30 SEC** - Start the oven and also use set a reheat time.
- 10 **ECO** - Used to turn the AC power on the oven.

Operation Procedure

- Plug power supply cord into 230V AC 50Hz power outlet.
- Press eco button until beep sounds and display is turned on.
- After placing the food in a suitable container, open the oven door and put it on the glass tray. The glass tray and roller guide must always be in place during cooking.
- Close the door. Make sure that it is firmly closed.
- The oven door can be opened at any time during operation by pushing the door open button. The oven will automatically shut off. To restart the oven, close the door and then push the START button.
- The oven automatically cooks on full power unless set to a lower power level.
- The display will show ": 0" when the oven is plugged in, press and hold Eco button until display is turned on and beep sounds.
- Display will be returned to the ": 0" when the cooking time ends.
- When the STOP/CLEAR button is pushed during the oven operation, the oven stops cooking and all information

retained. To erase all information, push the STOP/CLEAR button once more.

- If the START button is pushed and the oven does not operate, check the area between the door and door seal for obstructions and make sure the door is closed securely. The oven will not start cooking until the door is completely closed or the program has been reset.
- Display turns off after 10 minutes.

Make sure the oven is properly installed and plugged into the electrical outlet.



TRUMA COMBI BOILER

Introduction

The liquefied gas heater 'Truma Combi' is a warm air heater with an integrated hot water boiler (10 litre volume) the burner operates fan supported, which ensures trouble-free function even when on the move.

The heater can be used to heat the room, heat the room and water at the same time or just heat hot water.

In warmer conditions the water contents are heated using the small burner. Once the water temperature is reached, the burner switches off.

In winter or in lower temperatures the unit will automatically select the required power setting according to the temperature difference between the temperature set on the control panel and the current room temperature. When the boiler is filled, the water is automatically heated as well. The water temperature will depend upon the operational mode and the heater output.

If the heater is not to be used when freezing conditions are expected the water system MUST be drained. NO warranty claim will be accepted for cases of frost damage.

Before using the heating system for the first time please ensure that the 12v system is turned ON at the control panel over the doorway and that the gas cylinder and isolation valve are turned on.

Fig opposite shows the controls for the Truma Combi Boiler

If the gas system is leaking or if there is a smell of gas:

- Extinguish all naked flames.
- Open all doors and windows.
- Close all quick-acting valves and gas cylinders
- Do not smoke
- Do not activate any electrical switches
- Ask an expert to inspect the entire system.

Repairs may only be carried out by a certificated repairer.

Any modifications to the unit, including the accessories, exhaust duct and cowl, or the use of spare parts and accessories that are important to the operation of the system that are not original Truma parts and failure to follow instructions will cancel any warranty and indemnify Truma of any liability claims.

It also becomes illegal to use the appliance, and in some countries this even makes it illegal to use the vehicle.

The gas supply's operation pressure (30 mbar) must be the same as the unit's operating pressure (see type plate).

The vehicle owner is always responsible for arranging periodic inspections.

Liquefied gas equipment may not be used when refuelling, in multi storey car parks, in garages or on ferries.

During the initial operation of a brand new appliance (or after it has not been used for some time), a slight amount of fumes and smell maybe noticed for a short while. It is a good idea to heat the device up several times and to make sure that the area is well ventilated.

Heat-sensitive items such as aerosols or flammable liquids may not be stored in the same compartment as the heater because this area maybe subjected to high temperatures.

On applicable models Isotherm duct provides a gentle convection heat across the back of the front seating areas.



TRUMA COMBI BOILER

TRUMA CONTROL PANEL

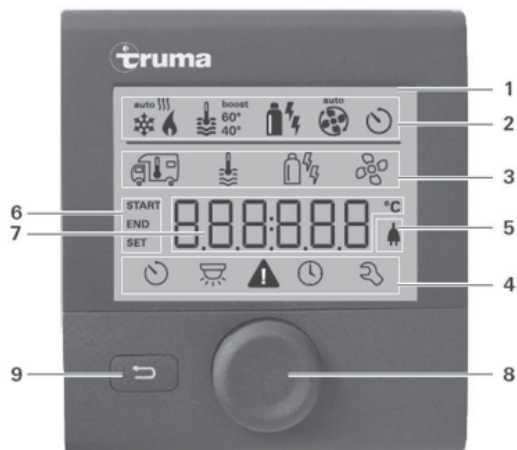

- 1 = Display
- 2 = Status line
- 3 = Menu line (above)
- 4 = Menu line (below)
- 5 = Display of mains voltage 230V (shore power)
- 6 = Display timer
- 7 = Settings / values
- 8 = Control knob / push button
- 9 = Back button









TRUMA COMBI BOILER



FUNCTIONS







To switch on/off press the control knob for longer than 3 seconds. The boiler starts with the last selected settings.

Turn the control knob right or left to move through the menu and also to increase/decrease values, click the control knob to select a menu item or accept a value.

Menu		Settings/Description	
	CHANGE THE ROOM TEMPERATURE		Heater Settable temperature range 5 - 30°C (1°C steps). This symbol will flash until the required room temperature is reached.
			CHANGE THE WARM WATER LEVEL
		boost	Targeted, fast heating of the content of the boiler. Once the water temperature is reached, the room is heated again.
		40°	Warm water temperature 40°C.
		60°	Warm water temperature 60°C.
	SELECT POWER TYPE		Gas
			EL1 - Electro
			EL2 - Electro
			Mix 1 (mixed mode) – Gas + Electro
			Mix 2 (mixed mode) – Gas + Electro



TRUMA COMBI BOILER

Menu		Settings/Description	
	SELECT FAN LEVEL (When the heater unit is connected)		Vent Circulating air, if no device is in operation, 9 speed levels can be selected.
			Eco Low fan level.
			Mid High fan level (only Combi Gas).
			Fast heating of the room. Available, if the difference between the selected and current room temperature is >10°C.
	SET TIMER	<ul style="list-style-type: none"> • Enter start time • Enter end time point • Set the room temperature • Set the warm water level • Select power type • Select fan level • Activate the timer <p>The timer remains active, even for several days, until it is deactivated.</p>	

Filling the Unit with Water

- Ensure that the cold water drain tap is closed (the level should be in the horizontal position).
- Turn on the hot tap in either the bathroom or the kitchen. Position the tap in the HOT position.
- Position the handles on the water pump so that it is directed into the heater.
- Leave the tap open to let the air escape from the water system while the tank is filling. The heater is full once the water flows from the tap. For more detailed information on operating the Truma Combi boiler please refer to TRUMA appliance instructions that can be found in your information wallet.

It is essential that you do not block/ obstruct or cover the flue outlet from your Truma Combi Boiler.



ALDE TOUCHSCREEN CONTROL PANEL

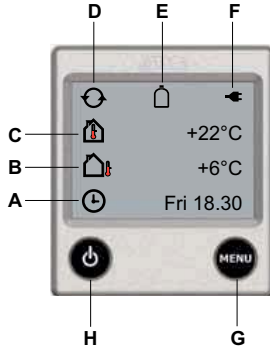

A. Clock

The clock shows day and time.

B. Outdoor temperature

The outdoor temperature is displayed if a sensor probe is mounted.

C. Indoor temperature

The indoor temperature is displayed automatically.

D. Circulation pump

This symbol is displayed when the heating pump is requested.

E. LPG bottle full/empty

This symbol is displayed when the sensor on the cylinder changeover is connected and activated.

F. 230 volts

This symbol is displayed when 230V is connected to the boiler.

G. MENU button

Button for setting menu.

H. On/Off button

Shut down / turn on the boiler.

PRE-START CHECKS

1. Ensure the system is filled with Glycol before starting the boiler, check the expansion tank level. The fluid should be 10mm above the minimum mark when cold.
2. Ensure adequate LPG Propane, 230V and 12V supplies are connected and turned on. The control panel should be active and display the 230V connection symbol.
3. Turn the boiler 'ON' using the control panel, then scroll across and raise the desired room temperature to +30°C. The circulation pump symbol should appear. Visually check in the expansion tank that the pump is operating.
4. Scroll across and turn on the 3kW electric heater using the panel. Wait for 10 minutes and check that the upper flow pipe on the boiler is getting hot. The bottom return pipe may also be warm.
5. Scroll back and turn on the gas burner using the control panel. You might not be able to hear it start, so visually check the flue outside to confirm the boiler is operating. Wait for 10 minutes and check the lower return pipe on the boiler. It should now be hot and the boiler fully operational.



ALDE HEATING

- Isolation switch is a MCU (Mini Circuit Breaker) in the PDU located in offside bed.

From standby mode to setting menu

When on standby, the indoor temperature is displayed and the outdoor temperature is displayed if an outdoor temperature sensor has been connected. The background lights up when you press the screen or the MENU button. Start the setting menu by pressing the MENU button. The background lights up and those functions which can be set are displayed. The settings are automatically saved after 10 seconds. The control panel reverts to standby automatically after 30 seconds if no buttons are pressed (or if the MENU button in the setting menu is pressed).



Control panel in standby

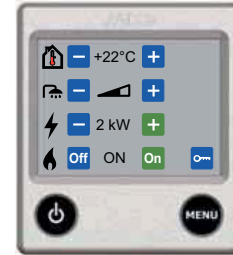

Control panel in setting

Set the required temperature

The temperature can be set from +5°C to +30°C in steps of 0.5°C. Warm water is always available (50°C) when the boiler is on and running on LPG or electricity. During summer, when only warm water is required, adjust the temperature setting to below the surrounding temperature so that the central heating pump does not start.

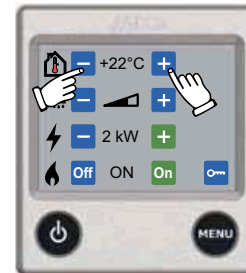



1. The temperature displayed is the temperature which is set at present (in this case 22.0°C).
2. Raise the temperature by pressing the + button. Lower the temperature by pressing the - button.
3. The settings are ready and the central heating pump will work at the set temperature.

Extra warm water

If you need more warm water, you can raise the water temperature temporarily from 50°C to 65°C. After 30 minutes, the boiler reverts to normal operation. When you have selected more warm water the circulation pump stops.



1. Increase the quantity of warm water by pressing the + button. When activated the plus symbol changes colour to green.
2. The settings are ready.

If you wish to revert to the basic warm water settings before 30 minutes have expired.

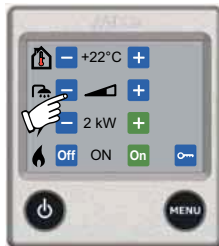

1. Reset the warm water by pressing the - button.
2. The settings are ready.

Heating with electricity

Do as follows to activate heating with electricity. The greater the power, the better the heating performance. In choosing between electricity and gas, electricity is given priority.

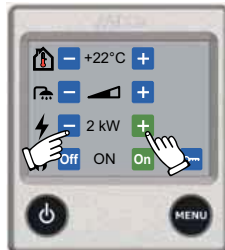

1. Start and step between the various power steps (Off, 1kW, 2kW or 3kW) with the + button or - button. The set value is displayed on the screen. When activated the plus symbol changes colour to green. (Certain boilers are equipped with max. 2kW).
2. The settings are ready and the boiler is working at set temperature.
3. In order to switch off gas operation, press Off.

Heating with gas

Do as follows to activate heating with gas. If both electricity and gas are selected, electricity is given priority.

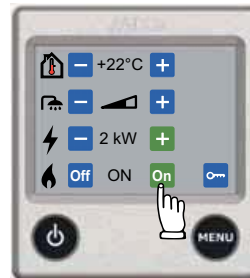



ALDE HEATING

Unlocking the tool menu

It is possible to go from the setting menu to the tool menu. Under the tool menu you can access the other functions of the control panel.

1. The control panel in setting menu. Press the unlock symbol.
2. The control panel in unlocking menu. Press on open padlock, then OK or MENU to unlock the tools menu. When activated the symbol changes colour to green.
3. The control panel in setting menu with unlocked tool menu. In order to get to the tool menu, press the symbol.

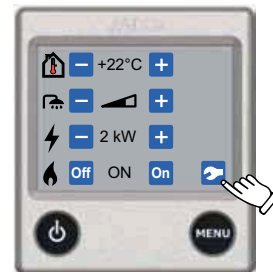
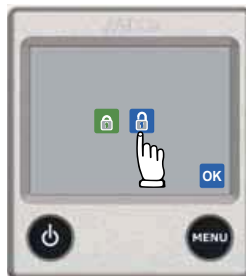









ALDE QUICK START OPERATING INSTRUCTIONS

Select the options using the touchscreen.

External Start Function (Clubman/Delta)

When leaving the caravan, set the desired room temperature and power source. Under the tool menu select EXT (external start) setting and then switch the control panel off. The control panel will now switch on and off via the signal device (Phantom Tracker).

	STARTING THE BOILER	To start the boiler, press the on/off button and the start-up display is shown. The boiler starts with the last selected setting.
	SETTING MENU	Start the setting menu by pressing the MENU button. The background lights up and those functions which can be set are displayed. The settings are automatically saved after 10 seconds.
	SET THE REQUIRED TEMPERATURE	<p>The temperature can be set from +5°C to +30°C in steps of 0.5°C.</p> <p>Warm water is always available (50°C) when the boiler is on and running on LPG or electricity.</p> <p>During summer when only warm water is required, adjust the temperature setting to below the surrounding temperature so that the central heating pump does not start.</p> <p>Raise and lower the temperature by pressing the + and – buttons on the touchscreen.</p>
	EXTRA WARM WATER	<p>If you need more warm water you can raise the water temperature temporarily from 50°C to 65°C.</p> <p>After 30 minutes, the boiler reverts to normal operation.</p>
	HEATING WITH ELECTRICITY	In choosing between electricity and gas, electricity is given priority. Start and step between the various power steps with the + or – button on the touchscreen.
	HEATING WITH GAS	Start the gas operation by pressing 'On' on the touchscreen. The On symbol is activated and changes colour to green. In order to switch off gas operation, press Off.
	TOOL MENU	It is possible to go from the setting menu to the tool menu by pressing the tool menu icon then selected the open padlock. From here you can access various functions such as the clock, timer and temperature offset.



THETFORD TOILETS

THETFORD C-260 CASSETTE TOILET (Lexon/Stellar/Quasar/Ariva)

INTRODUCTION

The Thetford Cassette Toilet is a high quality product. The toilet forms an integral part of your caravan or camper bathroom, thanks to its functional design which combines modern styling and ease of use. The C-260 Cassette Toilet is manufactured from high quality synthetic materials which makes it a durable, user and maintenance friendly toilet.

The toilet is made up of two parts: a permanently fixed part and a Waste Holding Tank that is accessible from the outside. The removable Waste Holding Tank is located under the toilet bowl and can be removed via a door on the outside of the caravan or camper.

The operating instructions cover Thetford Cassette Toilet models C-260S, C-260CS (models connected to the vehicle's central water tank) and C-260CWE (model with its own flush-water tank). There are differences in the use of these models. Please ensure that you follow the instructions that apply to your toilet model.

Standard C-260

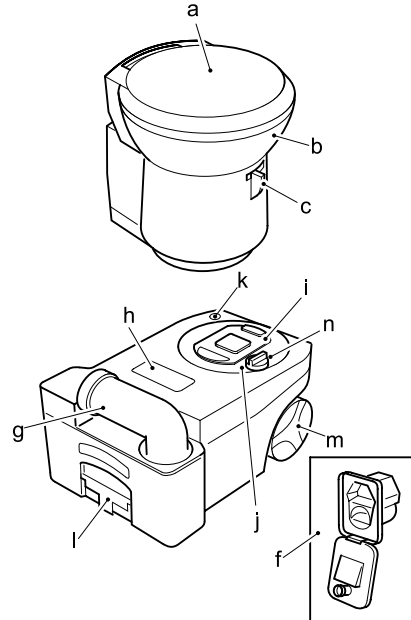

Optional features C-260

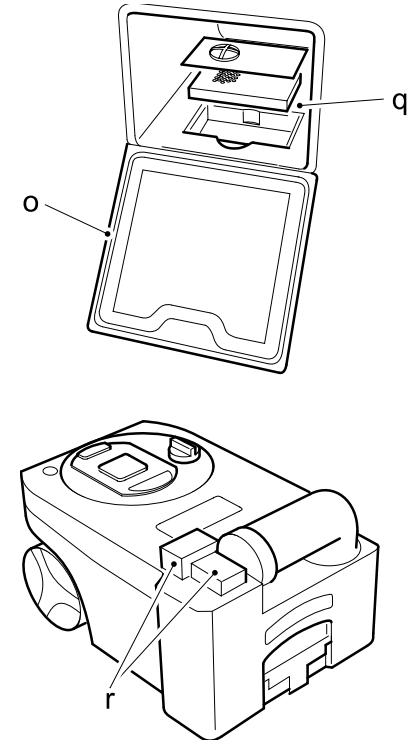

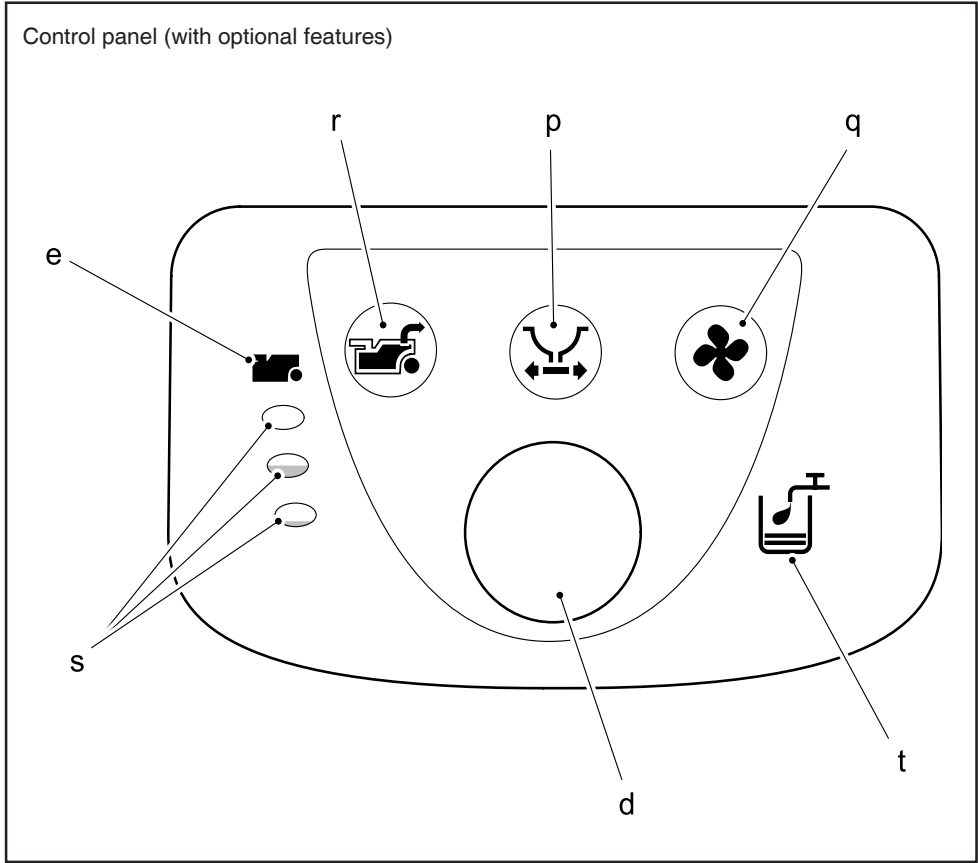

PARTS

- a) Removable Seat and Lid
- b) Swivelling Toilet Bowl
- c) Blade Handle
- d) Flush Button
- e) Waste Holding Tank Level Indicator
- f) Water Filling Door (only if toilet has own flush-water tank)
- g) Rotating Emptying Spout
- h) Automatic Pressure Release Vent
- i) Sliding Cover
- j) Removable Mechanism
- k) Vent Plunger
- l) Pull-out Handle
- m) Wheels
- n) Blade Opener
- o) Access Door to Waste Holding Tank

Optional Features

- p) Electric Blade
- q) Automatic Ventilator
- r) Waste Pump-Out System
- s) Waste Holding Tank Multi-Level Indicator
- t) Flush-Water Tank Level Indicator (only if toilet has its own flush-water tank)

Note: Optional features can be bought from Thetford dealerships.



THETFORD TOILETS

Preparing for use (standard)

1. Open the access door on the outside of your caravan or camper.
2. Remove the Waste Holding Tank by pulling the safety catch (which holds the tank in place) upwards.
3. Pull the Waste Holding Tank outward to the stop. Tip it slightly and take the tank fully out.
4. Place the tank upright and turn the rotating emptying spout upwards. The emptying spout ensures that the tank can be easily and hygienically emptied.
5. Remove the cap, with the measuring cup inside, from the emptying spout and pour the correct dosage of Thetford toilet fluid (see product label) into the holding tank. This avoids unpleasant smells and keeps the inside of the tank clean. Next add approximately 2 litres of water - enough to ensure that the bottom of the Waste Holding Tank is covered. Screw the cap back onto the emptying spout and turn back to its original position.

Note: The emptying spout measuring cup is supplied in the same packaging as your Thetford manual.

WARNING: Never add toilet fluid directly via the blade or the toilet bowl as this could damage the lip seal of the Waste Holding Tank. Always pour the fluids via the emptying spout.

6. Slide the Waste Holding Tank back into its original position via the access door. Make sure that it is secured with the safety catch. Close the access door and lock it. Your Thetford toilet is now ready to use.

WARNING: Never use force if you cannot get the tank back into place easily. This may cause serious damage. If blockage occurs, always check if the blade handle is in the correct (closed) position.

7. For toilets with own Flush-Water Tank: Open the water filling door and fill the flush-water tank with the correct dosage of Aqua Rinse. This Thetford toilet fluid keeps the flush water fresh and improves the flushing. Next, fill up the flush-water tank with clean water (approximately 8 litres) using a ferry can or hose. Your toilet is now ready to use.

Preparing for use with Optional Features

8. Automatic Ventilator: Open the access door on the outside of your caravan and remove the Waste Holding Tank (as described above).
9. Remove the filter housing cover and if no filter is present, place a new filter into the filter housing. Peel off the sticker lids on the filter. Place back the cover of the filter housing.

Using the toilet (standard)

10. Turn the bowl to the desired position with the lid closed and using both hands.
11. To activate the control panel, press the flush-button once. The control panel display will stay activated for approximately 5 minutes. Run some water into the bowl by pressing the flush button again briefly.
12. The toilet may be used with the blade open or closed. To open the blade, slide the blade handle under the toilet bowl sideways. After use, open the blade (if still closed) and flush the toilet by pressing the flush button for several seconds (if necessary re-activate the control panel). Close the blade after use.



WARNING: If your toilet has its own flush-water tank, please make sure that you do not travel with a flush-water tank that is too full. Do not travel with water in the toilet bowl. Failure to adhere to this notice may result in water damage to your caravan or motor home.

Using the toilet with Optional Features

13. **Electric Blade:** Push the electric blade button on the control display to electrically open or close the blade. In the case of failure, you can manually open or close the blade by sliding the small handle under the toilet bowl sideways.
14. **Automatic Ventilator:** The ventilator automatically starts when the control panel is activated (by pressing the flush button) and will automatically shut off after approximately 5 minutes. The Automatic Ventilator Indicator will flash until automatic shut-off occurs. If you want to stop the ventilator, press the Automatic Ventilator button. If you want to re-start the ventilator, press the button again (the LED will start flashing again).
15. **Flush Water Tank Level Indicator** (only for toilets with own flush-water tank): When the Flush Water Tank Level Indicator lights up, refill the flush-water tank, as only about 1.5 litres of water is left in the tank, which is sufficient for approximately 2 flushes.

Emptying

The Waste Holding Tank has a capacity of 18 litres and requires emptying when the red light (LED) on the toilet control display lights up, when the Waste Holding Tank only has capacity for approximately 2 more litres, which is no more than two to three further uses.

Make sure that the blade is closed. Open the access door located outside the vehicle, pull the safety catch upwards and remove the Waste Holding Tank.

16. Place the Waste Holding Tank in an upright position (Pull-Out Handle at the top, Wheels at the bottom). Slide the handle sideways - to the front of the tank - until it snaps out of its locked position.
17. Pull the handle up and wheel the Waste Holding Tank to an authorized waste disposal point.
18. Push the handle back into its locked position. Turn the emptying spout upwards and remove the cap from the spout. Hold the Waste Holding Tank in such a way that during emptying you can operate the vent plunger with your thumb. To empty the tank without splashing, depress the vent plunger while emptying the tank. After emptying, rinse the tank and blade thoroughly with water.

WARNING: Do not seriously shake the tank or use high pressure water cleaners. This may cause damage to the tank's interior.

Note: The vent plunger should only be depressed once the emptying spout is pointing downwards. Prepare the toilet for re-use if required. Slide the Waste Holding Tank into the toilet and close the access door.

Emptying with Optional Features

19. **Waste Holding Tank Multi-Level Indicator:**
The lower lamp indicates that the Waste Holding Tank is almost empty; the middle lamp indicates that it is more than half full; when the upper lamp lights up, the tank needs emptying as it can only take 2 - 3 further uses.
Note: The Waste Holding Tank Level Indicator will flash when the holding tank is not present. In this case the toilet will not flush.
20. **Waste Pump-Out System:** When activating the control panel this feature automatically lights up. When the Waste Holding Tank Level Indicator illuminates, press the Waste Pump-Out button to pump out the waste from the holding tank into the vehicle's waste tank. The button will flash while the waste is being



THETFORD TOILETS

pumped and will stop automatically (after approximately 5 minutes) when all waste has been transferred. If the vehicle's waste tank is full, the Waste Pump-Out light will flash rapidly and no pump-out will be possible until the central tank is emptied. (Check the level of the vehicle's waste tank on the vehicle's central console). After the Waste Holding Tank has been emptied, there will be approximately 1.5 litres of waste left in the tank. This is normal. Add 2 litres of water and a correct dosage of Thetford toilet fluids to the Waste Holding Tank.

CAUTION: It is vital that the correct amount of toilet fluid is added to ensure the proper breakdown of the waste in the holding tank. Only use the system when the tank is full. Using the system too often on an empty tank can cause damage to the pump, which could cause the system to fail.

CLEANING AND MAINTENANCE

The toilet should be cleaned and maintained regularly, depending on the amount of use. To clean Thetford toilets, we advise using water and Thetford Bathroom Cleaner.

Note: Never use bleach, vinegar or other powerful household cleaners that contain these substances. These may cause permanent damage to the seals and other toilet components.

Toilet Bowl

- Squirt Thetford Bathroom Cleaner into the toilet bowl.
- Flush the toilet bowl with water and wipe down the rest of the toilet with a damp cloth.
- Clean seat and lid The seat and lid can easily be removed: Lift the seat and lid assembly and pull the round pins (inside the assembly) outwards from the pin holes. After cleaning, replace the seat and lid by positioning the round pins in front of the pin holes and push the lid and seat downwards.
- To keep your flush water fresh and to prevent deposits from forming in your toilet bowl, add a correct dosage of Aqua Rinse in your flush water tank, if present, on your toilet.

Tip! For a really shining toilet, dry with a soft dry cloth after cleaning.

Waste Holding Tank

To keep your Waste Holding Tank fresh and clean, Thetford has developed a number of different toilet fluids. Thetford toilet fluids suppress smells, reduce formation of gas, promote breakdown of toilet waste and increase the life span of a mobile toilet. We advise a thorough cleaning of the Waste Holding Tank once each season. Next to using Thetford's Cassette Tank Cleaner, the powerful cleaning agent for the periodical cleaning of the Waste Holding Tank of your toilet, we suggest the following: -

- Remove the removable mechanism from the Waste Holding Tank by turning it anti-clockwise and rinse it under a tap.
- Remove the cover plate from the Automatic Pressure Release Vent by prising it up using a small screwdriver. Use one hand to push the Automatic Pressure Release Vent open while holding the float of the Automatic Pressure Release Vent on the inside of the tank with the other hand. Push the float upwards, turn it 180 degrees and remove it from below. Remove the rubber seal underneath the float. Rinse the float and rubber seal under a tap. Replace the rubber seal and float for the Automatic Pressure Release Vent using the same method in reverse.



The rubber seals in the toilet (the lip seal, the mechanism seal, the automatic pressure release vent seal and the cap seal) should be regularly cleaned with water and treated with Thetford High Grade Seal Lubricant. This will ensure that the seals remain flexible and in good condition. If the toilet is not to be used for any length of time, it is important to treat the seals with Thetford High Grade Seal Lubricant after cleaning.

Note: Never use Vaseline or any vegetable oil except olive oil. These may cause leakage or malfunction. The lip seal is a part of the toilet that is subject to wear. Depending upon the extent and manner of use, the seals will become less effective and will need replacing periodically.

Cleaning and Maintenance for Optional Features

- **Automatic Ventilation:** The filter of the Automatic Ventilation needs to be renewed periodically. After approximately 4 full weeks of use, the filter loses its absorption power.
- **Pump-Out Waste System:** To ensure optimal functionality of the Pump-Out Waste System, periodical maintenance of the tube and pump is recommended. After emptying the Waste Holding Tank completely, fill it with clean water and empty it again. This will clean the pump

and the hose. Do this once every 3 weeks when on holiday. This should ensure proper operation of the system.

Winter operation

You can use your Thetford Cassette Toilet as normal in cold weather as long as the toilet is situated in a heated location. If there is a risk of freezing we advise that the toilet is drained by following the instructions under 'Storage'. For environmental reasons the use of antifreeze, such as that used in car radiators, is not recommended.

Storage

It is important that you follow the instructions below if you do not expect to use your Thetford toilet for a long (winter) period.

- Activate the Control Panel by pressing the flush button. Open the blade and press the flush button until water stops flowing into the bowl. Close the blade. Open the access door on the outside of your caravan or camper and empty the Waste Holding Tank at an authorized waste dump. Follow the instructions for cleaning and maintenance. To allow the Waste Holding Tank to dry, do not place the cap back on the emptying spout of the tank.
21. If the toilet has its own flush-water tank, place a sufficiently large bowl under the

drain tube to catch the remaining water from the flush-water tank and remove the drain plug. When no more water exits, put the drain plug on the drain tube, put it back in its original position and close the access door. If the toilet is connected to the vehicle's water tank, please follow your vehicle's instructions for draining the central water system. If your toilet is optionally featured with a Waste Pump-Out System, take out the Waste Holding Tank and completely clean it (see Cleaning and Maintenance). After cleaning, fill it with water, put it back and empty it via the waste pump-out system. Repeat this twice.



THETFORD TOILETS

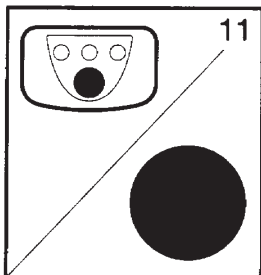
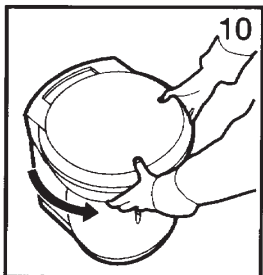
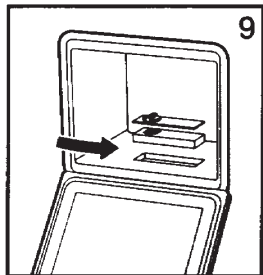
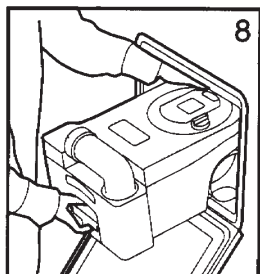
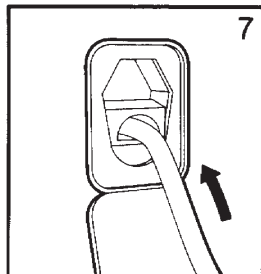
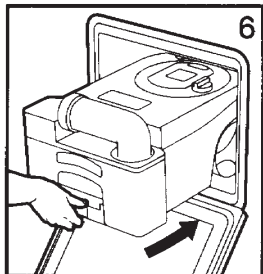
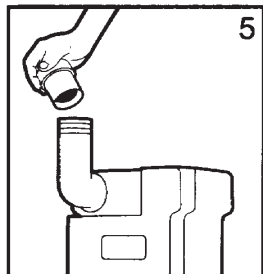
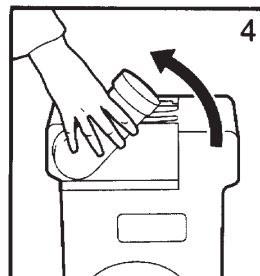
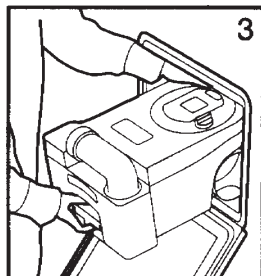
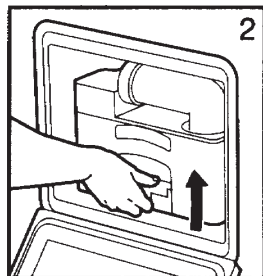
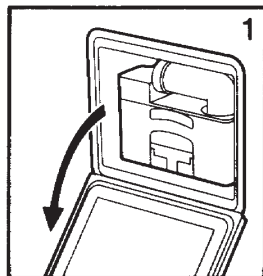

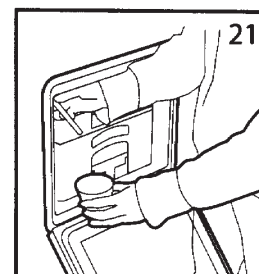
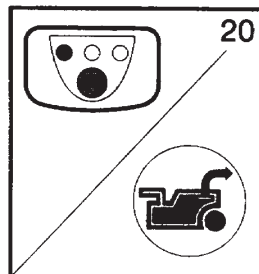
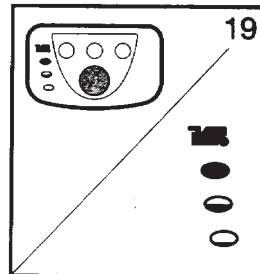
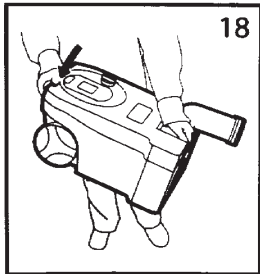
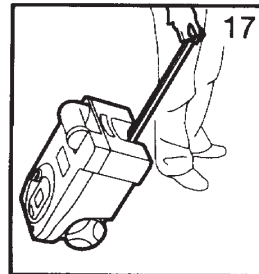
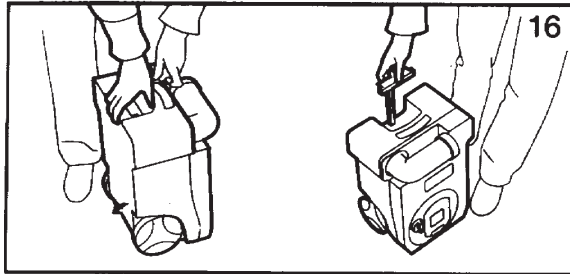
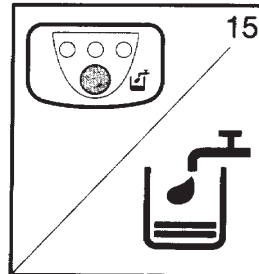
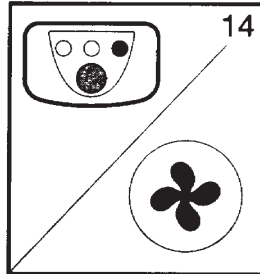
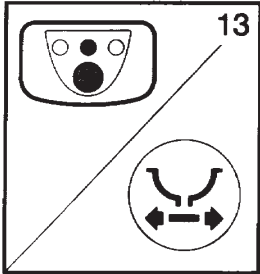



DOMETIC TOILET

DOMETIC CTW4050 TOILET (Clubman/Delta)

Introduction

These instructions provide you with the necessary guidance for the proper use of the toilet. Observe the safety instructions in particular. Observing the instructions and handling recommendations is important for dealing with the toilet safely and for protecting you from injury and the toilet from damage.

The CTW4050 cassette toilet consists of a fixed toilet and a removable waste holding, mobile cassette tank. The cassette can be accessed from the outside through a door.

Description of parts

1. Removable cover and seat.
2. Toilet bowl.
3. Emptying blade for the toilet bowl.
4. Fresh water tank (capacity depends on the model).
5. Level indicator / flush (control panel).
6. Cassette tank (capacity 19L).
7. Pour out spout.
8. Vent button for emptying.
9. Service door.
10. Pull-out handle (cassette tank movable on wheels).

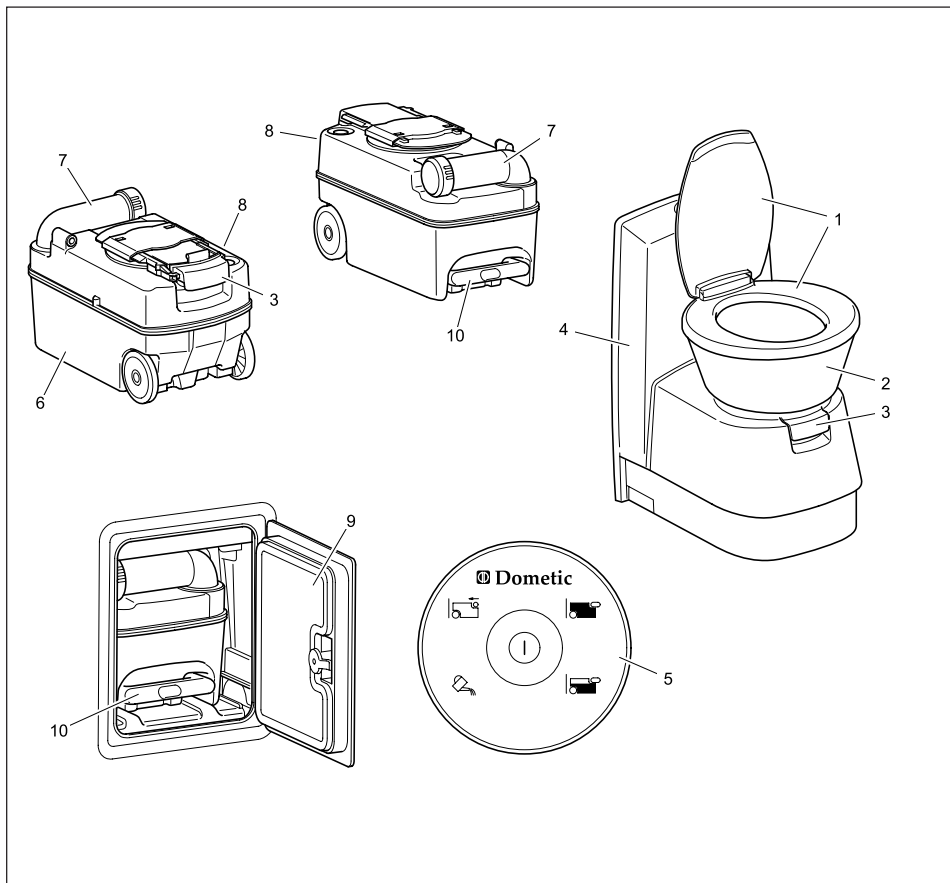



Cleaning

Before using the toilet for the first time, we recommend cleaning the toilet on the inside and outside. Use a soft cloth and lukewarm water with a mild detergent. Then rinse the surfaces with clear water.

Maintenance

Regularly clean all seals on the toilet and cassette tank. Carry out this cleaning every month for frequent usage.

Dismantling the cassette seal

Remove the cassette tank and place it on a solid surface. Dismantle the entire blade, as illustrated in the following five steps. A seal can now be removed, cleaned or replaced.

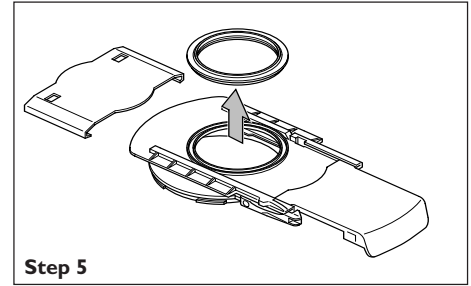
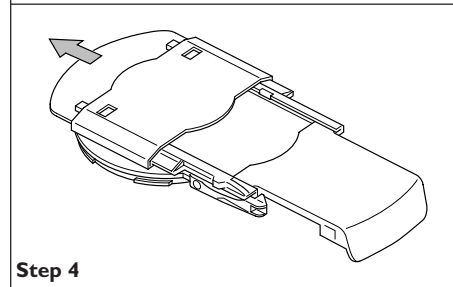
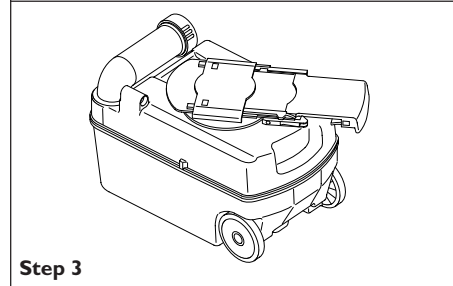
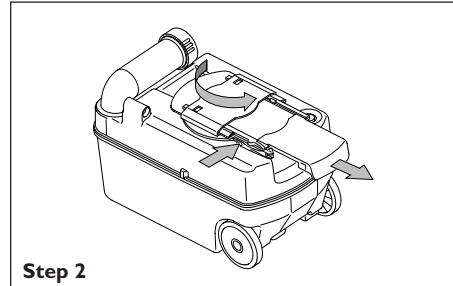
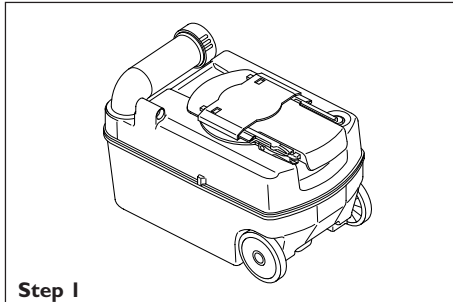

Preparing cassette tank

Before you use the toilet for the first time:

1. Open the service door.

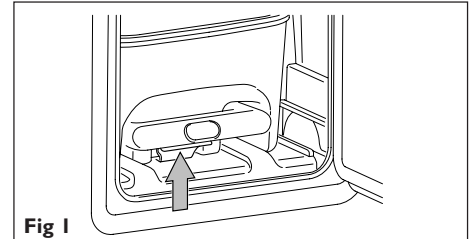

2. Unlock the cassette tank by pushing the lock upwards (fig 1).



DOMETIC TOILET

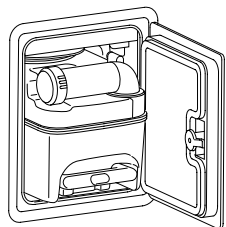

Fig 2

3. Pull the cassette out to the stop and remove it completely (fig 2).

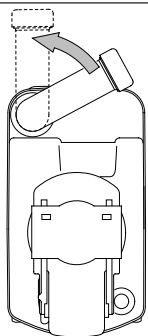

Fig 3

4. Place the cassette tank in an upright position and turn the pour out spout upwards by approximately 90 deg (fig 3).

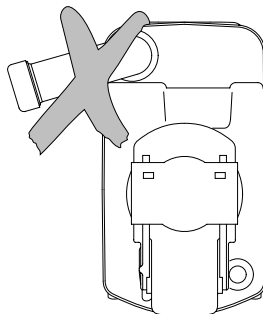

Fig 4

Caution: Avoid turning the spout by more than 90 deg. as it may otherwise come loose (fig 4).

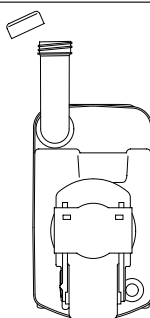

Fig 5

5. Fill a small amount of sanitary additive into the cassette tank via the spout.
6. Put the cassette back in and push it in until it stops.

Note: Ensure that the tank can be smoothly inserted. Do not use force!

7. The cassette tank locks shut automatically when inserted. But check that the cassette tank is firmly attached.
8. Close and lock the service door.

Filling fresh water tank

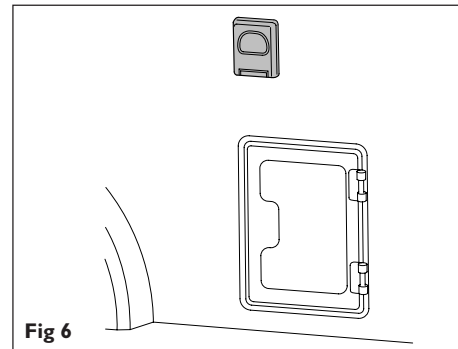

Fig 6

Fill the fresh water tank via the filling piece on the outside of the vehicle (fig 6). The quantity depends on the tank used (on-board tank or integrated toilet tank, option).



Control Panel

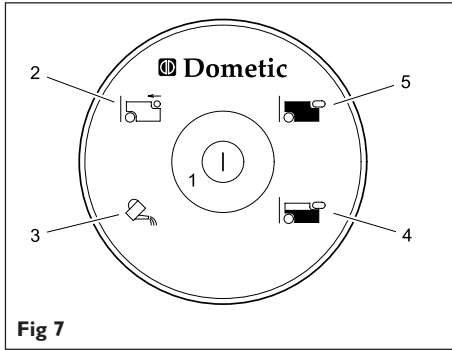

Fig 7

1 = "Flush" button

2 = "Cassette tank removed" display

3 = "Fill fresh water tank" display•

4 = "Cassette tank 3/4 full" display

5 = "Cassette tank full" display

* not connected as a rule when using the on-board tank.

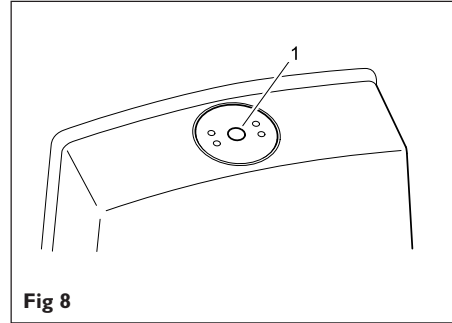

Fig 8

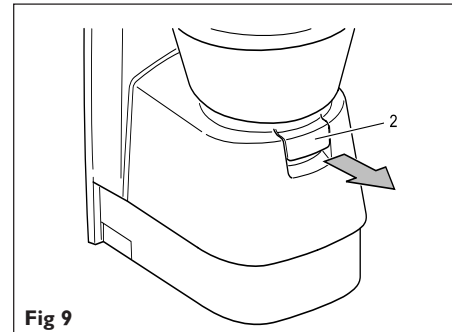

Fig 9

Emptying the cassette tank

Empty the cassette tank when the level indicator LED lights up.

The cassette tank has a capacity of 19L. When LED 4 lights up, the tank is approximately 80% full. This means that it can be used only a couple of times.

1. Remove the cassette tank (see fig 1).
2. Carry or wheel the holding tank to the nearest authorised waste disposal point.
3. The cassette tank is provided with wheels and a pull-out handle. To unlock the handle, push in the button in middle of the handle.

Pull out the handle until it stops.

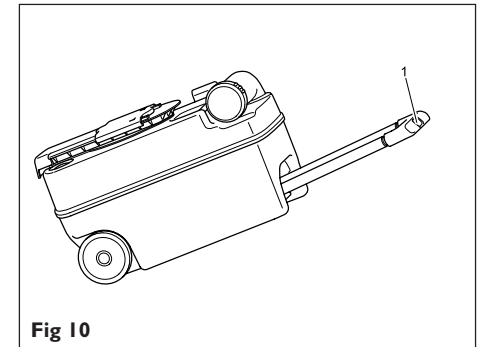
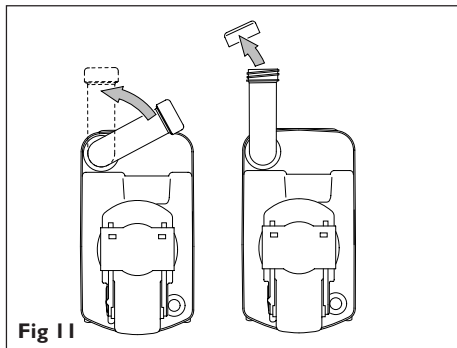

Fig 10



DOMETIC TOILET

4. To bring the handle back into its original position, press the handle's unlock key and push the handle back into the cassette (fig 10, 1).



5. Place the cassette tank in an upright position and turn the emptying spout upwards (fig 11). Remove the cap from the spout (fig 11).

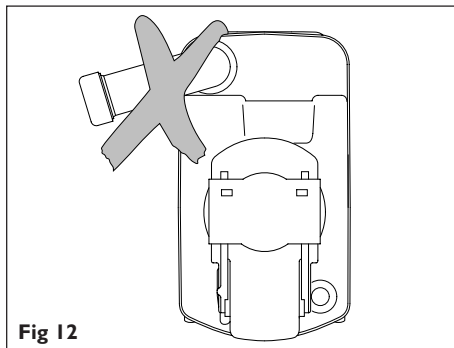

Fig 12

Caution: Avoid turning the spout by more than 90 deg. as it may otherwise come loose (fig 12).

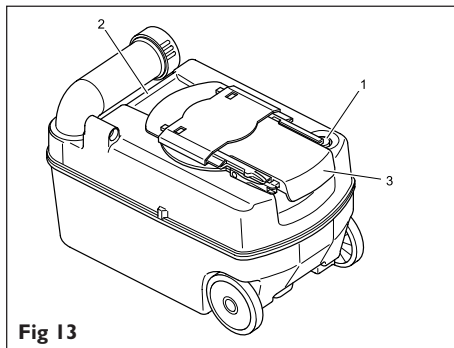

Fig 13

6. Hold the cassette tank with one hand by the handle (fig 13, 2). With the other hand hold it at the blade handle (fig 13, 3) so that you can operate the vent button (fig 13, 1) during emptying.
7. The vent button should only be pressed once the emptying spout is pointing downwards. The tank empties evenly and without squirting.
8. After emptying, flush the cassette tank thoroughly with water. Then make the tank operational again as described in section "Preparing cassette tank" before inserting it in the toilet.



Exchanging the fuse on the control panel

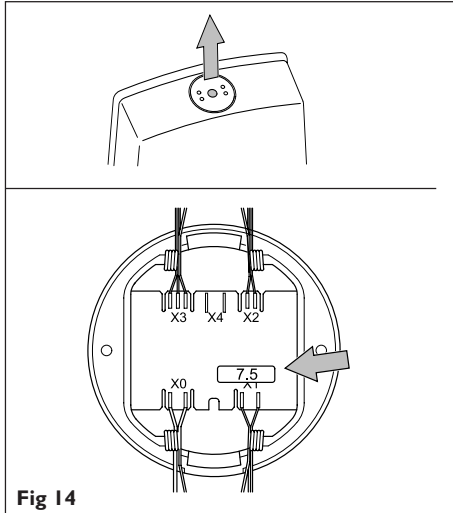

Fig 14

Lift the control panel with a suitable tool and pull it out of the tank case or the wall (fig 14). The fuse (automotive fuse 7.5A) is located on the bottom side of the control panel.

Winter use

You can continue to use the cassette also in winter, as long as the toilet and the cassette are situated in a frost-protected location.

If this is not the case, empty the fresh water tank, the cassette tank and the water pipes of fresh water supply. This prevents damage due to frost.

WARNING: Do not use anti-freeze agents. Such agents can damage the sanitation system.

Decommissioning

If you wish to decommission the toilet for long periods of time, empty the fresh water tank and the water supply system fully.

- Clean the toilet.
- Press the flush button until there is no remaining water left in the pipes.
- Then empty the cassette tank and rinse it thoroughly.
- To allow the tank to dry, do not place the cap back on the emptying spout of the waste tank.



AWNING/ROOFLIGHTS

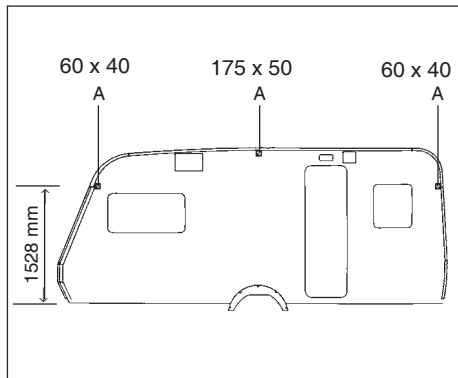

AWNING FIXING POINTS

In all Lunar Caravans fixing blocks for the awning brackets are now fitted as per the diagram (position A). The centre block is determined from centre of wheel arch and just below awning rail.

The end fixing points are just above window height front and rear, approximately 60mm long x 40mm, 1528mm above the underside of the floor (i.e. from top of skirt).

Care must be taken when fixing the brackets and a suitable sealant used.

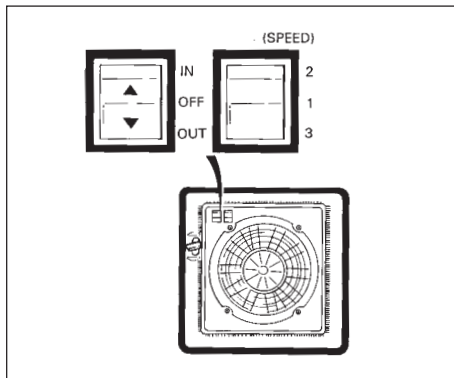

12 VOLT ROOF MOUNTED EXTRACTOR FAN

The fan is a double glazed rooflight. Its side operating mechanism allows a completely free central opening with built-in fixed ventilation when closed.

TILT & SLIDE ROOFLIGHT

To open - turn the handles to release the rooflight. Push it upwards and slide it towards the front of the caravan.

Before travelling ensure the rooflight is in the fully closed and locked position.

A fully adjustable flyscreen and black out screen are built into the frame.



STATUS TV ANTENNA

OPERATING THE SYSTEM

Travelling

When positioning the Antenna Dome please allow for the following:-

DO NOT TRAVEL:-

- With the Antenna raised
- With the Antenna set for vertical signals

To reduce the possibility of damage when travelling, have the antenna pointing towards the rear of your caravan/motor home.

Operating

1. Loosen the Mast Locking Collar and raise the antenna.
2. Determine whether the TV transmissions are horizontal or vertical and position accordingly.
3. Switch On the Amplifier and the LED will illuminate and check the gain is set to MIN by rotating the button anti-clockwise.
4. Rotate the antenna.
 - RED - Poor signal - keep turning.
 - YELLOW - getting better - slow down.
 - GREEN - Signals located, ready to GO.
5. If there's no GREEN increase the Gain and repeat the 360 degree rotation.
6. Once the transmitter has been located increase the Gain to MAX.

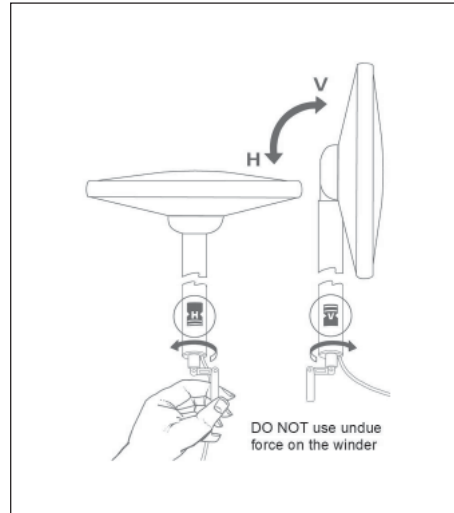

7. Turn on your television set and tune in. This will be necessary at all new locations.
8. Secure the Antenna by hand tightening the Mast Locking Collar.

IMPORTANT

You may detect more than one transmitter. Choose the position that gives you the most channels when tuning in your TV.

In poor signal areas the LED may only glow YELLOW.

In strong signal areas you may need to reduce the gain by rotating the Control anti-clockwise.

Removing the Antenna

A permanently fitted Status can be easily removed leaving only the Mounting Foot and rubber gaiter.

1. Unplug the antenna lead from the Amplifier.
2. Loosen the Mast Locking Collar and lift off whilst feeding out the mast, coaxial cable and plug.
3. Push the Blanking Cap supplied into place.

IMPORTANT - The Blanking Cap is a temporary seal and is not recommended for long term use.

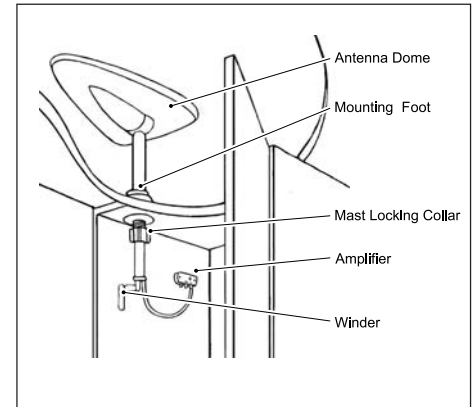



ANTENNA

Signal	Symptom	Action
Very Poor	No picture or sound, TV freezing, severe pixilation, break up and picutre drop out	Check the amplifier gain is set to maximum (rotate clockwise). Check antenna alignment which must be directed at the transmitter. Ensure the antennas polarity is correct, whether horizontal or vertical. Bypass the amplifier by following "Short Hook-Up Test 1"
Poor	Moderate pixilation and sound distortion	
Medium	Minor pixilation will not receive all channels	
Good	Stable picture, good sound quality will receive all channels	N/A
Strong	Possible pixilation, picture break up and drop out.	Reduce the amplifier gain (rotate anti-clockwise). Rotate antenna AWAY from the transmitter.
Very Strong	No picture or sound, TV freezing, severe pixilation, break up and picture drop out.	Rotate antenna AWAY from transmitter. Switch 'OFF' the amplifier and turn the gain control to maximum (rotate clockwise).
After performing any of the 'Actions' above you must re-tune your TV		

Guarantee

The Status Antenna has a return to base guarantee against defective parts and workmanship for two years or a period determined by the vehicle manufacturer. This does not include any malfunction resulting from improper use, incorrect installation, accidental or malicious damage. To support your guarantee claim a dated Proof of Purchase will be required.

This does not affect your statutory rights. Any queries concerning warranty please contact ourselves.

Fault Finding

The following are some of the key areas we suggest you check which generally solve the most common problems encountered with the operation of the Status antenna.

Coaxial Connections

It is critical that all connections in the system are fitted correctly and only quality plugs have been used.

Coaxial Cable

Sharp bends, kinks and hot surfaces can easily damage coaxial cable and should be avoided. Coaxial cable, if placed in close proximity to electrical cables, transformers or other pieces of electrical equipment, may pick up electrical interference causing picture quality to deteriorate, especially in poor reception areas. Excess cable should be removed and NOT coiled as this may cause picture distortion. An inspection of the routing of the cable is highly recommended to ensure all is correct.

Gain Control

In normal use the button should be rotated clockwise for maximum. In strong signal areas the amplification may need to be reduced. To reduce amplification rotate the button anti-clockwise until picture quality improves. The button rotates through 270 degrees from MAX to MIN



LED Light

Should the LED on the Amplifier not light, firstly check there is power to the unit. Secondly check the polarity is correct. Otherwise contact ourselves for further assistance.

Short Hook Up - Test 1

This test isolates the wiring from the Amplifier through to your TV/Radio points.

Unplug the coaxial plugs from the 'TV' sockets of the Amplifier and using your TV fly lead with Converter 1 supplied. Connect your TV to the Amplifier.

Please ensure the Antenna Dome is plugged directly into the 'ANT-IN' socket of the Amplifier and switch on. Tune in your TV for the strongest signal.

If the picture quality improves the fault lies with the wiring of the system between the Amplifier and the TV outlet socket.

Short Hook Up - Test 2

This test isolates the Amplifier by connecting your TV direct to the Antenna.

Unplug the Antenna from the Amplifier and connector Connector 2 supplied to the plug on the cable end. Using your TV flylead connect the antenna directly to your TV. Tune in your TV for the strongest signal.

If the picture quality improves the fault lies with the Vision Plus Amplifier.

Antenna Dome Co-axial Cable

Check the routing of the coaxial cable from the Antenna Dome to the Amplifier. Check to ensure there are no kinks or trapped cable or if there are loops of surplus cable which could be affecting performance.

Customer Help Line

Should you still be experiencing difficulties and require assistance, please do not hesitate to contact us at the address below.

MAINTENANCE

Gaiter

We suggest you periodically check the gaiter for any signs of damage or for wear.

If the rubber is caught by overhead obstructions it may rip or tear which would allow water to work its way into the fabric of the roof.

Over an extended period of time the gaiter will wear at the contact area with the mast. Should the gaiter begin to fail the signs will be small amounts of water dripping down the outside of the mast, however, the design of the Gaiter and Mounting Foot ensures that water cannot work its way into the fabric of the roof. Should this problem occur contact ourselves for a replacement unit.

Spares & Repairs

Should you require any parts for replacements or repair please log on to www.gradeuk.co.uk or contact ourselves on 0115 986 7151.

Vision Plus

8 Finch Close
Lenton Lane
Nottingham
NG7 2NN
0115 986 7151
info@visionplus.co.uk
www.visionplus.co.uk



LIGHTS, CD/RADIO/MP3

LED LIGHTING

LED lighting is non replaceable.

Please refer to electrics section, control panel, for information on dimming functionality.

CD/RADIO/MP3

Your caravan is fitted with a Pioneer CD/ Radio Unit. Please refer to manufacturers manual for further functionality and instructions.



STINGER 310 ALARM

If your caravan has been fitted with a Stinger 310 Alarm, this provides comprehensive protection for your caravan when parked or coupled to your tow vehicle, as well as protecting the contents. The alarm system is controlled by a key fob, which can also switch the awning light on/off. If you insure with the Caravan Club, K. Drewe (Insurance) or Caravan Guard Insurance, you should be eligible for a discount on your premiums.

OPERATION

Each Stinger 310 is supplied with two key fob style radio controllers, which are used to operate the alarm system.

USING THE ALARM

The Stinger 310 comes complete with a PIR internal movement sensor that detects body movement within the vehicle. If you are leaving pets within the vehicle, the system should be armed without the PIR sensor active.

The Stinger 310 alarm also incorporates an electronic tilt and motion sensor which works automatically and does not need adjustment for normal use.

When the alarm is triggered the siren will sound for 2 minutes. Following the 2 minute period the alarm will then deactivate for 15 seconds and then rearm. The alarm siren can be turned off at any point by pressing the key fob arm/disarm button.

	LED TORCH BUTTON	Press and hold the button to use the torch.
	ARM/DISARM BUTTON	Press and release the button to arm the alarm (one beep). Press and release the button to disarm the alarm (two short beeps). To arm the alarm without the PIR movement sensor, press and hold the button and release after you hear one beep followed by two beeps.
	AWNING LIGHT BUTTON	Press and release the button to turn the awning light on or off. (Please note that this light must be switched on with its own switch before it can be switched off then back on using the key fob).
P	PROGRAMMING MODE BUTTON	Press and hold the button for 10 seconds to access the 3 programming modes.



FLYSCREENS, BLINDS & ROOFLIGHTS

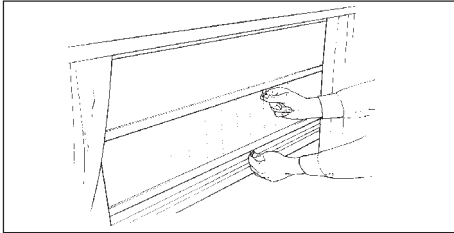

FLYSCREENS AND SUNBLINDS

Important: Blinds should be checked for holes and tears when you take delivery of your caravan. Failure to report a fault at this stage will result in a claim under warranty being rejected.

OPERATING INSTRUCTIONS (Quasar/Lexon only)

Flyscreen

Pull the flyscreen fully down and gently push the crossbar towards the window so that it locates in the retaining “cut out” within the rear channel of the lateral guides. To release, gently pull the crossbar downwards and toward you and allow the tension of the spring mechanism to rewind the flyscreen upwards.

DO NOT RELEASE THE HANDLE – causing the flyscreen to “whiplash” upwards – as this will cause damage to the spring mechanism.

Sunscreen

The front channel of the lateral guides has a number of “cut outs” to enable the sunscreen to be retained at various heights – look inside the lateral guides to locate these. To raise or lower the sunscreen follow similar procedure as with the flyscreen.

TENSION ADJUSTMENT

The tension adjustment clips are located at the left side of the cassette – the top one is for the flyscreen and the lower one for the sunscreen.

Insert screwdriver into tension clip, apply gentle inward pressure and rotate tension clip one or two clockwise turns to increase tension or anti-clockwise to reduce tension. Gently release the inward pressure to enable tension clip to re-engage into its internal ratchet. Check tension and, if necessary, repeat until the crossbars return to their top positions without too much tension or assistance. **DO NOT OVERTENSION.**

Note: It is not recommended that the window blinds are retained in the “down” position whilst the caravan is being towed.

WINTERISATION

The flyscreen/sunscreen should NOT be left in the “down” position through the winter as this may cause the spring mechanism to lose tension.

However to rectify this, gently pull crossbar downwards and toward you then allow the tension remaining in the mechanism to rewind, when it stops pull the crossbar downwards and upwards five or six times to restore correct tension.

Should the blinds not retract fully, please follow Tension Adjustment instructions.

DOOR FLYSCREEN

To close

Pull handle/crossbar across door aperture until hook engages on closing profile.

To open

- a) **From inside:** To release hook, pull handle/crossbar slightly toward you then, still holding the handle/crossbar, allow the tension to pull the flyscreen back into the cassette.
- b) **From outside:** To release hook, push handle/crossbar away from you then, still holding the handle/crossbar, allow the tension to pull the flyscreen back into the cassette.

CAUTION: To avoid damage to the tension mechanism DO NOT allow the flyscreen to “whiplash” back into the cassette.

Cleaning

Use a damp cloth and, if necessary, a normal household cleaner without abrasives or solvents.



Opening and closing the panoramic rooflight

Opening the rooflight

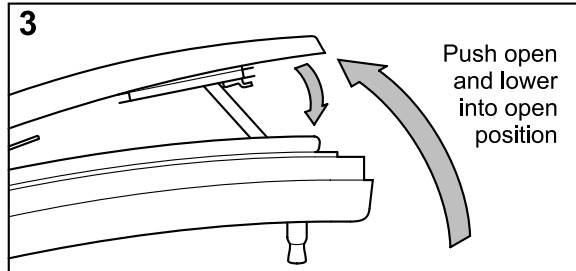
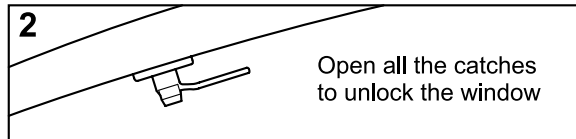
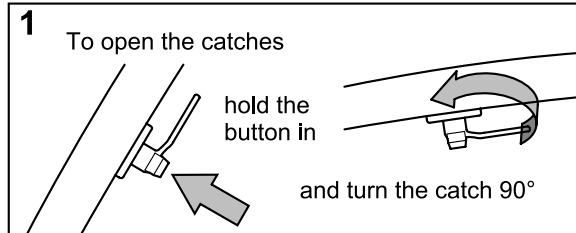

Closing the rooflight

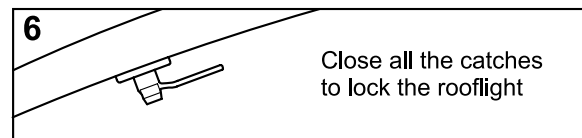
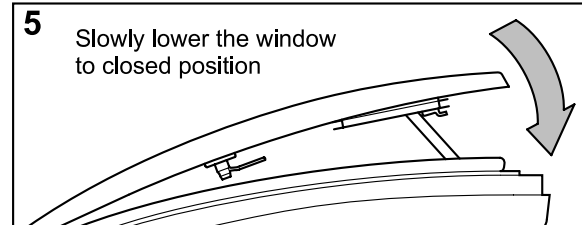
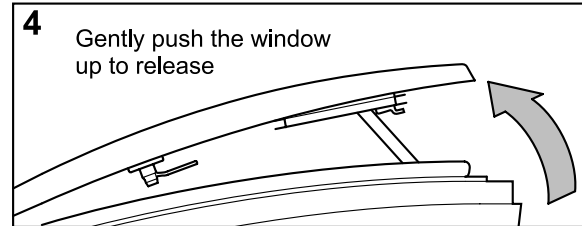



WINDOWS AND BODY

WINDOWS

The windows on your caravan are made from acrylic. If you consider the instructions below, the windows will stay in good shape for a long time. Windows also require periodic maintenance and checking by your dealer at least once per year.

Operation



When the vehicle is in motion all windows must be fully closed.



Never use the blinds in direct sunlight. If you use the blind in direct sunlight, even for a short period, heat will accumulate between the window and blind possibly causing damage to the window such as bending/ballooning.

Your windows are equipped with either handles with buttons or handles with stays. Please observe the following operating instructions.

Handles with buttons - Always push the button when opening/closing the handle.

Stays in step version - You will hear clicks when opening the window. Every click represents the position in which a window can stay opened. When closing the window, you must open it till the end and then close. Do not try to close it without first opening it as wide as it goes, as this will damage the stays.

Stays with knob screw - Always make sure to unscrew the knob before closing the window.

Catches - The catchers enable three positions of the window. The open position is where the handle is open placed on the outer part of the catcher. If the handle is placed in the middle of the catch, this is the position for ventilating. The closed position is where the handle is closed on the inner part of the catch.

Cleaning

1. Cleaning window profiles

To clean coloured and anodized profiles, use a soft cloth and water without any aggressive cleaning solvents. The use of any chemicals and abrasive cleaners could damage the surface of the profile.

2. Cleaning windows

Never use abrasive or corrosive substances or solvents on windows, such as turpentine, spirit or dishwasher detergents, as they will damage the acrylic and/or print. We recommend cleaning with a generous amount of water or mild cleaner intended for use on acrylic. There are some specialist plastic cleaning agents such as Plexus or Brilliantize which can be used if preferred. Cleaning with a dry cloth can damage the acrylic and leave scratches; always use a

moist sponge or moist soft cloth. Never clean windows with a high pressure washer. Please also note that a carwash can cause scratches or other damages.

Acrylic material can get scratched very easily. Please consider the above instructions for cleaning, so that you will not cause scratches or other damages.

Condensation

Condensation can appear on the window or between both panes. This is a normal occurrence that appears because of different temperatures inside and outside, moisture and the properties of acrylic itself. Condensation will disperse after some time. This doesn't mean that there is something wrong with the window or that it is leaking. With a properly ventilated vehicle you can in most cases prevent condensation.

How to overcome condensation

1. Improve ventilation

- (a) Leave rooflight open or use a self-ventilating rooflight.
- (b) Add to the ventilation by fitting more improved ventilators.
- (c) Put windows onto night vent position.
- (d) Leave doors open between compartments.



2. Help yourself tips

- (a) Do not wash crockery last thing at night, it creates more moisture in the air.
- (b) Do not boil water last thing at night and empty all water from kettles, etc.
- (c) Remove flowers or vases containing water from sleeping quarters.
- (d) Keep temperature at night to a minimum (hot air contains water vapour).
- (e) Increase ventilation to above normal in inclement or very wet weather.

Note: You cannot expect to eliminate condensation completely but following the hints above will help towards a more comfortable environment.



ABS PANELS

CLEANING THE CARAVAN BODY

It is wise to wash the caravan body regularly in order to maintain its good looks. Do not use aggressive cleaning materials as this will damage the paintwork over time. 'T Cut' or other similar cleaning compounds should only be used occasionally for stubborn marks. We suggest that a good quality car wax, applied at least once a year, will enhance the paintwork and ease the cleaning operation.

ABS Panels

ABS components need to be washed, waxed and taken care of like a car. Most stains or marks can be removed with mild detergent, but more stubborn marks may require a (fine grit) rubbing compound such as T-cut.

To help keep your ABS components looking almost like new, it is wise to wash the parts monthly (or more frequently) using mild detergent, but avoid using strong alkaline (e.g. tri-sodium phosphate) or acidic cleaners or abrasives. Waxing the components once or twice a year with a good grade paste wax will help to maintain the colour and finish.

BADGES

Resin coated badges are now being widely used within the caravan industry. Their upkeep is simple, use soap and water only to clean them. Under no circumstances should abrasive cleaners or solvent based solutions be used on them.



BUNK BED ASSEMBLY

The following step by step guide illustrates how to assemble the bunk bed.

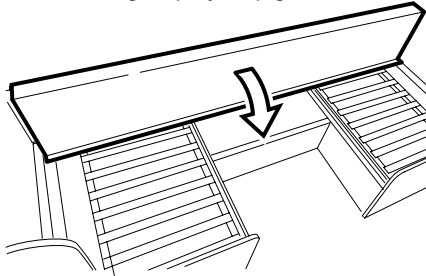

1. Pull the top edge of the bunk towards you.

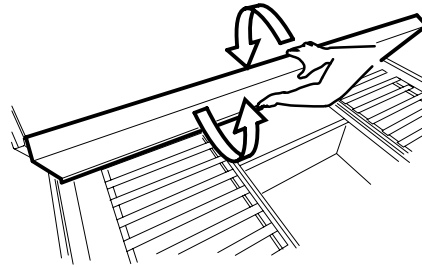

2 & 3. With your left hand on the bottom edge, lift upwards and towards you, while your right hand keeps the bunk steady.

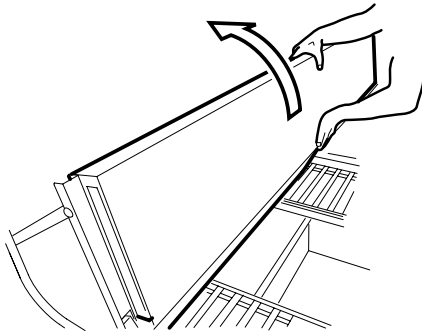
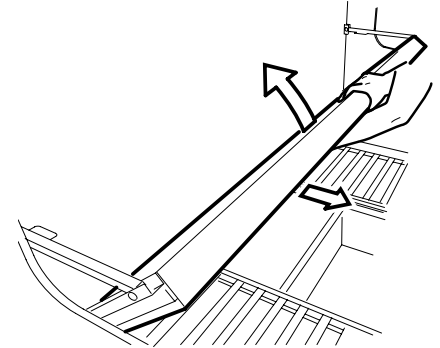

4 & 5. As the left hand passes the pivot point allow the right hand to slowly lower the bunk into the rest position.

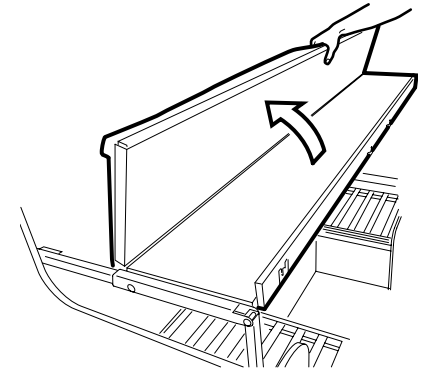
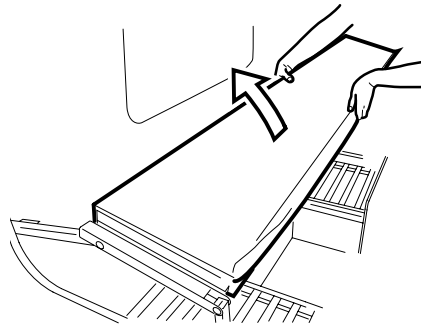

6. Fold the two part bunk into position.



BUNK BEDS

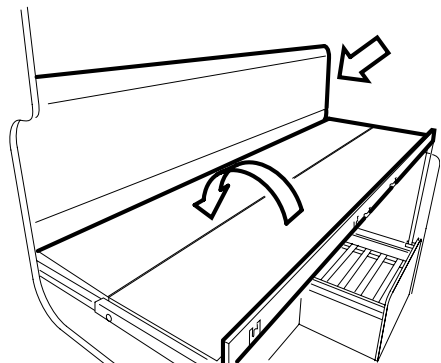

7. Fit the safety boards into position.

HOW TO MAINTAIN FURNITURE IN A CARAVAN



HOW TO PROPERLY MAINTAIN THE FURNITURE IN A CARAVAN

About Humidity

Air contains moisture – this is called humidity. The higher the temperature of the air the more water it is able to hold. Air at 20°C can hold a lot more moisture than air at 10°C. The term 'relative humidity' describes how much moisture air contains at a given temperature. 100% relative humidity means the air is holding as much moisture as it can at that temperature.

The more humid the air is in your caravan, the more energy it takes to warm your van because it is also warming the water in the air. This means it will be more expensive to heat!

A good range of indoor humidity for comfort and health is between 30-60% during cooler months of the year. Mould is likely to occur if the relative humidity indoors is 70% or more for long periods of time. Keeping humidity levels under 50% also helps to minimise or control dust mites.

It can be fun to buy a low cost humidity meter from a hardware store and track how humid the air in your caravan is. You might be surprised at how quickly it can change, from morning to night and as the weather changes.

About Condensation

When the humidity is high inside a van and it is cold outside the water vapour condenses on cold surfaces. What can cause dampness and condensation in your van?

- Lack of adequate ventilation and/or heating.
- Water coming in from the outside through leakage, seepage or open windows
- High levels of moisture/water vapour being produced inside the caravan

Humid air and condensation can also be generated by things people do on a daily basis.

- Cooking Up to 3 litres per day
- Showers and baths 1.5 litres per person
- Washing dishes Up to 1 litres per day
- Unflued gas heater 0.5-1.0 litre per hour of use
- Breathing, active adult 0.2 litres an hour per person
- Breathing, adult asleep 0.02 litres an hour per person

Because your Furniture pieces are made from wood or wooden materials they require attention and care to maintain their beauty over time.

Moisture in air can cause damage to furniture. Wood expands or contracts with an increase or decrease in the relative humidity in the air. A 40% -60% relative humidity is tolerable. Beyond this level, wood can expand. The damages can be quite visible if the relative humidity is higher than 80% for a long time. To prevent damage, assure the relative humidity of air is not too high for a long time by ventilate the van, using dehumidifiers or water adsorbent substances.

When wood is wet, wipe it dry. Do not just wait for the sun to dry it. The longer the water stays on the surface, the more damage it can do.

How to keep your caravan dry and avoid condensation

There are lots of things YOU can do to minimise dampness and condensation in your caravan.

The key actions:

- Provide ventilation and/or reduce relative humidity of air by , particularly in moisture-prone period of year (especially winter time) and when the moisture is produced in the van (cooking, shower)
- Reduce the amount of moisture produced in the van
- Increase heating to raise the temperature of the air and the cold surfaces



HOW TO MAINTAIN FURNITURE IN A CARAVAN

On dry days open some windows to allow humid air to ventilate out of the van. It is better to open a few windows a little throughout the whole caravan. This helps the air to move through the caravan. One window open wide may not be as effective. Try to do this as often as possible (at least once a week), but keep windows closed on wet days as damp air may increase indoor humidity.

High temperature can also damage the surfaces of your furniture. Protect them with protective table pads or place-mats when utilizing extremely hot utensils or dishes.

Do Not's

- use detergents or chemical cleaners on your furniture this may damage the finish,
- drop the pieces,
- expose the furniture to extreme hot, cold, rain, humidity or salinity,
- leave surfaces wet with beads of water standing

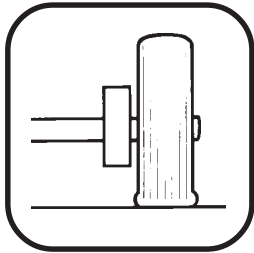

AL-KO CHASSIS & TYRES

Chassis	138
Running Gear	138
Braking System	138
General Maintenance	141
Tyres	142



AL-KO CHASSIS & TYRES

CHASSIS & UNDERGEAR

The Chassis

The design of the chassis undergear is suitable for the sustained high speeds permissible on mainland Europe (130 k.p.h.).

The maximum static load at the coupling head is 100kg.

The chassis is capable of carrying your caravan to the Maximum Technical Permissible Laden Weight as shown at the back of the service handbook.

The towing hitch (50mm dia. ball) operates on the over run principle; the application of the towing vehicle brakes automatically, mechanically operating the brakes of the caravan.

No manual assistance is needed to activate the auto reversing mechanism which automatically comes into operation when the towing vehicle starts to travel in a reverse direction. No lock off device needs to be used.

As the name implies, the corner steadies are designed to steady and stabilise the caravan when parked. They are not designed as jacks.

The AL-KO chassis is galvanised steel. To maintain protection to the steel, any rusting areas should be recoated using galvanising paint.

ALKO RUNNING GEAR

Coupling Head

The ball couplings are entirely automatic in operation and designed for one hand operation to suit the 50mm international ball recommended by the British Standards Institution, National Caravan Council and the Society of Motor Manufacturers and Traders.

It is expressly forbidden by the chassis manufacturer for holes to be drilled into the 'A' frame to accommodate a stabiliser bracket. A clamp must be used. Similarly, holes should not be drilled into the coupling head.

Operation of hitch head

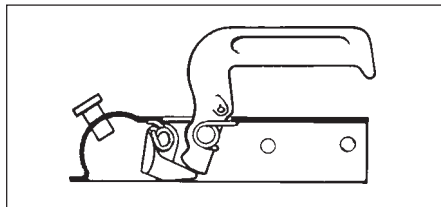

Lift handle upward and forward. Place the unlocked coupling onto the towing ball and with the slightest downward pressure it will lock onto the ball automatically. Ensure locking trigger returns to its free position and indicator button shows green before commencing to tow.

Uncoupling

Having lowered the jockey wheel to the ground, operate the handle as previously described. Lift the coupling clear of the towing ball either manually or by operating the telescopic jockey wheel.

BRAKING SYSTEM (AL-KO Automatic Reversing Brakes)

Forward Braking

In the free position, with the drawshaft fully extended and the handbrake lever fully forward "off position" the wheel brake shoes are clear of the drum and there is no friction.

During braking travel on the main shaft of the overrunning device is transmitted via the overrun lever, brake rod and bowden cables to the expander mechanism inside the wheel brake. The fully floating expander mechanism (2) forces the leading brake shoe (1) and by reaction the trailing brake shoe (3) into contact with the brake drum.

The friction between brake shoes and drum creates a tendency for both shoes and expander to move with the forward rotation (4) against the solid abutment of the adjuster box (5) which ensures both shoes remain in the braking position.



Reversing

During reversing the shaft of the overrunning device is subjected to its full travel which is transmitted in the normal manner to the expander mechanism inside the wheel brake.

The expander (2) forces both brake shoes (1 and 3) into contact with the drum as normal except with the backward rotation of the wheel the friction between brake shoes and drum is relieved.

The initial friction between brake shoes and drum ensures that both shoes plus the expander mechanism show a definite tendency to move in the direction of rotation i.e. reverse. The pressure generated by this action is applied to the spring loaded reverse lever (6) which is attached to the adjuster box (5) causing it to collapse.

The collapse of the reverse lever virtually eliminates the friction between brake shoes and drum thus allowing easy reversing. With only slight forward movement, the reverse lever returns to its normal position by virtue of the coil spring attached, and normal braking is immediately available.

Parking — Handbrake Application

The AL-KO automatic reversing brake system incorporates a patented device for added safety when parking on a reverse sloping site or a steep hill.

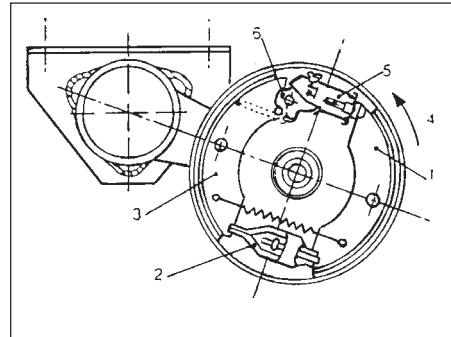

A spring cylinder has been added to the link between handbrake lever and centre brake rod.

Full application of the handbrake lever, i.e. as near vertical as possible, compresses a coil spring inside a steel cylinder and should any movement of the caravan occur following uncoupling the energy stored in the spring is immediately released to lock the wheel brakes.

It should be noted that it is good common practice to chock the wheels of a caravan when parking on steep slopes, or under adverse conditions such as loose or slippery surfaces.

AL-KO Trailer - Control (featured on Clubman and Delta range)

AL-KO Automatic Trailer Control is an electronic control system that reacts quickly to maintain the stability of the car and caravan. The system continually monitors the stability of the caravan during a journey and operates when an unstable condition is encountered. When AL-KO ATC activates, the driver will feel the vehicle being slowed down by the soft braking of the caravan.



AL-KO CHASSIS & TYRES

AL-KO ATC LED OPERATION

Display Colour	ATC Condition	Diagnosis	What to do	Outcome	Status
Green	ATC Active	Everything OK			
Green Flashing	ATC Active	Self test incomplete	Drive forward to detect movement to complete self test and recheck LED	Green (Constant)	Ready for journey
Red	ATC Inactive	Possible to continue journey	Remove 12S or 13 pin plug and wait five seconds.	Green	Ready for journey
			Reconnect plug	Red	ATC fault detected but can be driven
Red flashing	ATC has detected a fault	Do not continue with ATC connected	Remove 12S or 13 pin plug and wait five seconds	Green	Ready for journey
			Reconnect the plug.	Red (flashing)	ATC fault detected cannot be driven. Remove pushrod

Flashing Green - Simply the ATC is waiting to detect movement. Drive a few metres and the light will change to green.

Flashing Red - To provide further explanation if the constant RED light is showing: There are a number of errors that the ATC logs and some are self repairable by the customer but some will require the ATC to be monitored by the diagnostic equipment that is available and the AL-KO service engineers are trained to use.



GENERAL NOTES ON MAINTENANCE

Tyre Wear and Damage

The legal requirements for tread depth on motor vehicles apply also to caravans. In order to equalise wear it is suggested that wheels be balanced and changed around from time to time.

It is dangerous to neglect tyre damage and should you detect a blister, rupture or cut exposing the casing, or if it has suffered a violent impact (for example against a kerb), such that there is a risk of internal damage, it is advisable to have it examined by a tyre specialist as soon as possible.

Wheels

The condition of wheels should be checked regularly particularly for distortion of flanges and the wheel dish. Wheels damaged or distorted, or having wheel bolt seatings cracked or deformed must not be repaired.

Couplings

1. Clean and grease spherical seat, bearing parts and pivot pins regularly.
2. Thoroughly examine all moving parts for wear and correct functioning.
3. Couplings should never be drilled.

Towing Ball

The automobile towing ball should measure 50mm maximum and 49.5mm minimum (DIN 74058). If the ball is found to be worn it should be replaced immediately.

Overrunning Device

The device housing is packed with grease on assembly, but will require periodic maintenance to ensure smooth operation of the braking system.

1. Regrease the shaft bearings via the grease nipples provided at 3000 mile intervals and before storage.
2. Ensure correct functioning of all pivot pins and levers and oil regularly.

Jockey Wheel

Lubricate wheel and screw thread periodically.

Brake Linkage

All moving parts should be lubricated periodically to ensure their satisfactory operation.

It is recommended that all brake linkage threads are liberally smeared with grease for protection and as an aid to future adjustment of the system.

Corner Steadies

The screw and pivot pins should be lubricated periodically to ensure their satisfactory operation.

Braking System

At 500 miles then every 3000 miles or 1 year check and adjust brake linkage to compensate for any stretch of the bowden cables.

Check and adjust wheel brakes to compensate for wear.

IMPORTANT: When replacing the wheels you should tighten the nuts in rotation diagonally, taking care to tighten them equally.

The recommended torque is 88Nm (65lbs/ft) for steel wheels. Alloy wheels should be 115Nm (85lbs/ft).

CHECK THE WHEEL NUTS BEFORE STARTING EVERY JOURNEY

IMPORTANT NOTICE:

The caravan is manufactured for towing behind road cars and the 4 x 4 "off road" type of passenger car derivative. **THE CARAVAN IS NOT SUITABLE FOR TOWING BEHIND COMMERCIAL VEHICLES.**



AL-KO CHASSIS & TYRES

TYRES

PREPARATION

Tyres & Tyre Pressure

Safe driving and handling when towing a caravan is very important and one major factor which is frequently overlooked is the tyres. Look after your tyres properly and you will improve the safety and behaviour of your car and caravan.

Check the Pressures

Whatever tyres are fitted to the towing car and caravan it is essential to the safety and stability of the combination that all tyres are correctly inflated. This is a 'golden rule' of motoring and of caravanning in particular.

Pressures should be checked when the tyres are cold, not warm during or just after a run when they will be higher. Never reduce pressures when tyres are warm as they could be too low when they cool down.

The tyres specified by the caravan manufacturer are satisfactory for towing in the UK and are rated up to 80mph (130kph) at the maximum design weight of the caravan. In certain countries overseas it is legal to tow at higher speeds. If it is intended to visit such countries and tow up to the higher speed limits then it is important that the suitability of the tyres is first checked with a caravan dealer.

Tyres & Pressures

The tyres fitted, and the pressures needed, vary from model to model. Check the Service Handbook for specific recommendations for your model.

The speed limit for towing a caravan in the U.K. is 60mph. If a tyre needs to be replaced you must ensure that you refit a tyre of the same specification. The correct pressure for your car tyres will be found in the car handbook.

Fit the Right Tyres

As with all road vehicles it is always advisable to have the same type of tyres on all wheels i.e. both on the towing vehicle and the caravan but it is recognised that caravans and trailers will frequently have a different type from the towing vehicle.

If a wheel or tyre has been changed the replacement has to be of the same type of construction and size as on the other wheels.

General Recommendations

Because caravan tyres and wheels are rarely the same as those on your car you must not attempt to use the car wheel on your caravan if you should have a puncture.

Check your tyres regularly but particularly when the caravan has not been used for a long time. Vehicles such as caravans if not used in the winter should be thoroughly inspected prior to re-use during the summer months. Look particularly for any signs of age deterioration in the tyres such as sidewall cracking and carcass deformation. Tyres on a stationary vehicle, particularly if parked in coastal areas, always age and crack more quickly than those which are run frequently and, if your caravan is going to stand for a long time it is a good idea to cover the tyres with old sacks, etc. to shield them from direct light and, if possible, to jack the weight off the tyres. If in doubt at all about your tyres have them checked immediately by a tyre distributor.

WARNING: Prior to any journey the condition of the tyres should be inspected. The NCC recommend that tyres are replaced seven years from date of manufacture at the very latest.

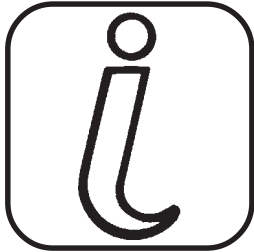

GENERAL DATA

Wiring Diagrams (Clubman - Delta)	143
Wiring Diagrams (Ariva, Quasar, Stellar & Lexon)	150
Light Bulb Replacements	156
Security	156
Owners Club	157
Owners Warranty	157
CRiS	158
Winterization Guide	159



GENERAL DATA

CLUBMAN - DELTA

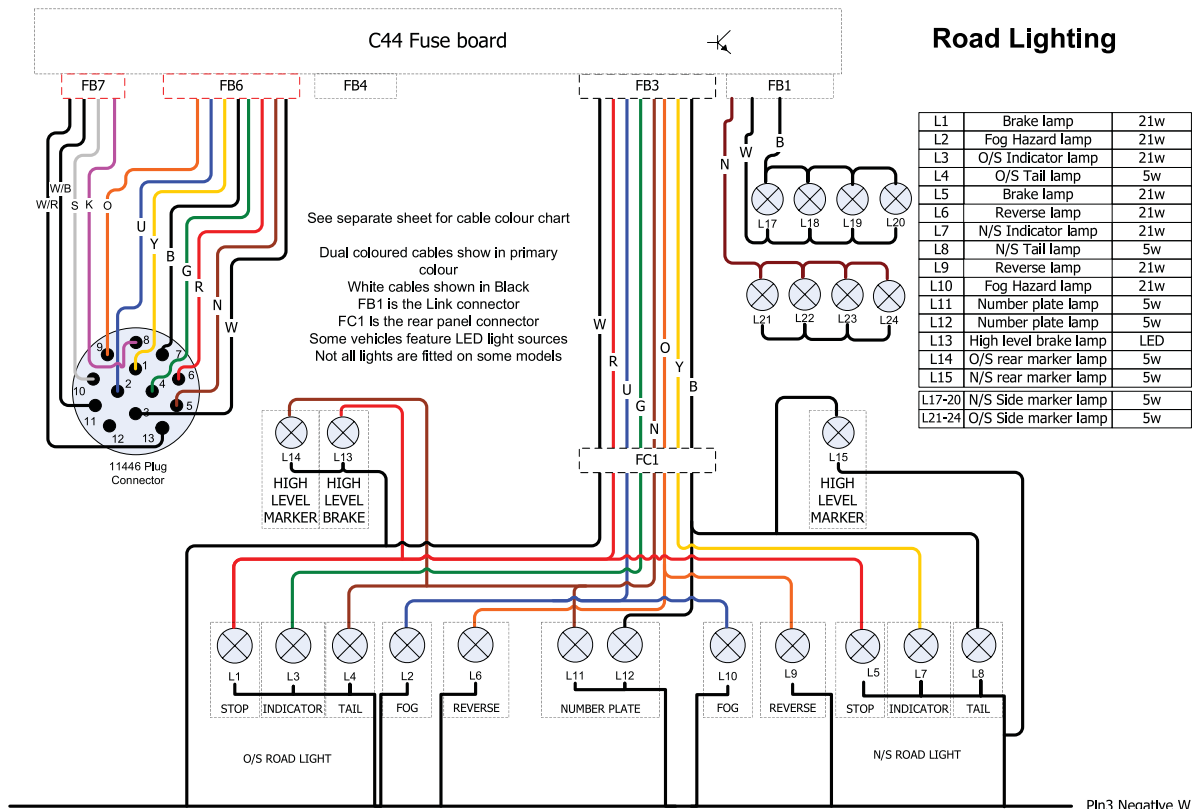



CLUBMAN - DELTA

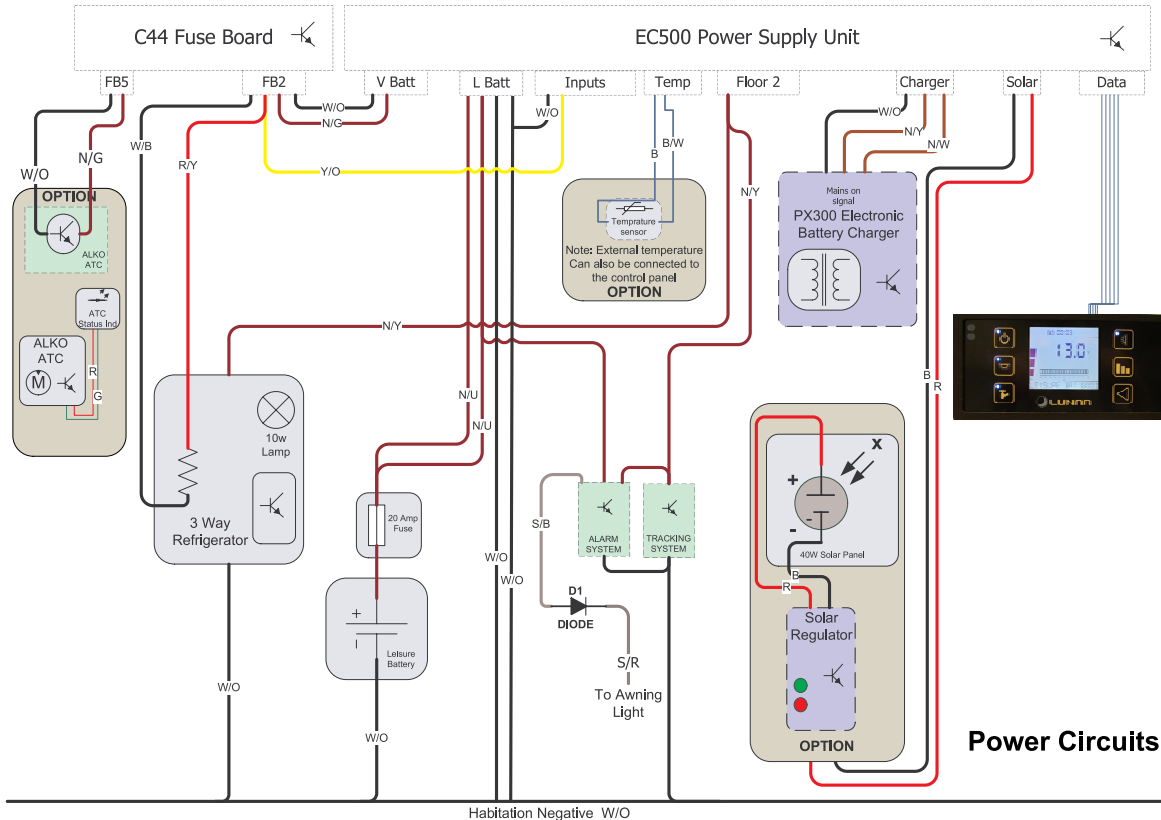

Power Circuits



GENERAL DATA

CLUBMAN - DELTA

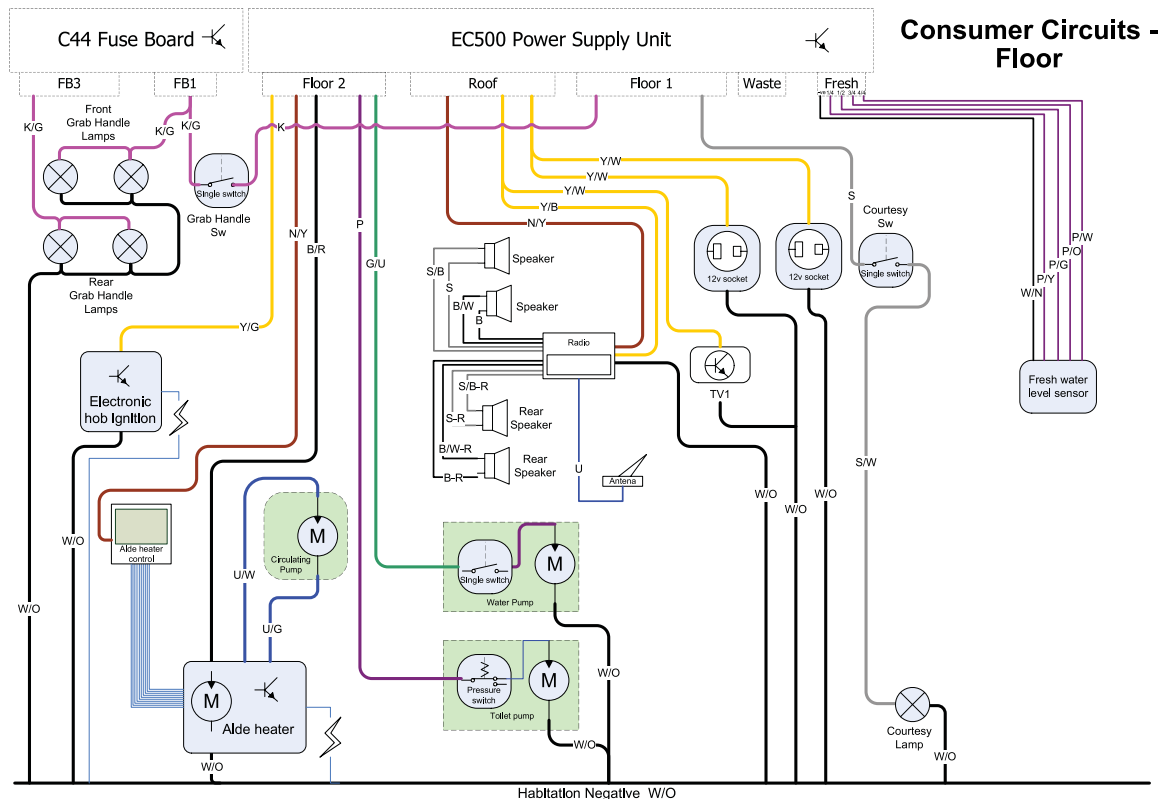



CLUBMAN - DELTA

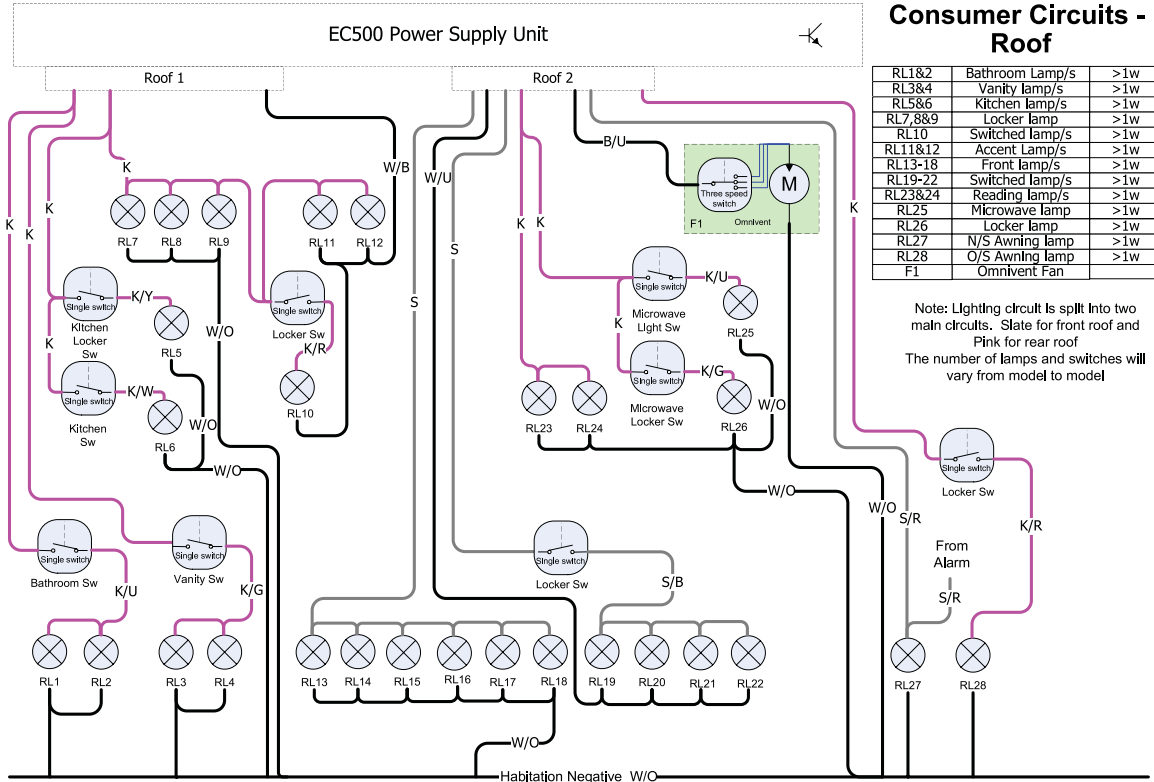

Consumer Circuits - Roof

RL1&2	Bathroom Lamp/s	>1w
RL3&4	Vanity lamp/s	>1w
RL5&6	Kitchen lamp/s	>1w
RL7,8&9	Locker lamp	>1w
RL10	Switched lamp/s	>1w
RL11&12	Accent Lamp/s	>1w
RL13-18	Front lamp/s	>1w
RL19-22	Switched lamp/s	>1w
RL23&24	Reading lamp/s	>1w
RL25	Microwave lamp	>1w
RL26	Locker lamp	>1w
RL27	N/S Awning Lamp	>1w
RL28	O/S Awning Lamp	>1w
F1	Omnivent Fan	

Note: Lighting circuit is split into two main circuits. Slate for front roof and Pink for rear roof
The number of lamps and switches will vary from model to model



GENERAL DATA

CLUBMAN - DELTA

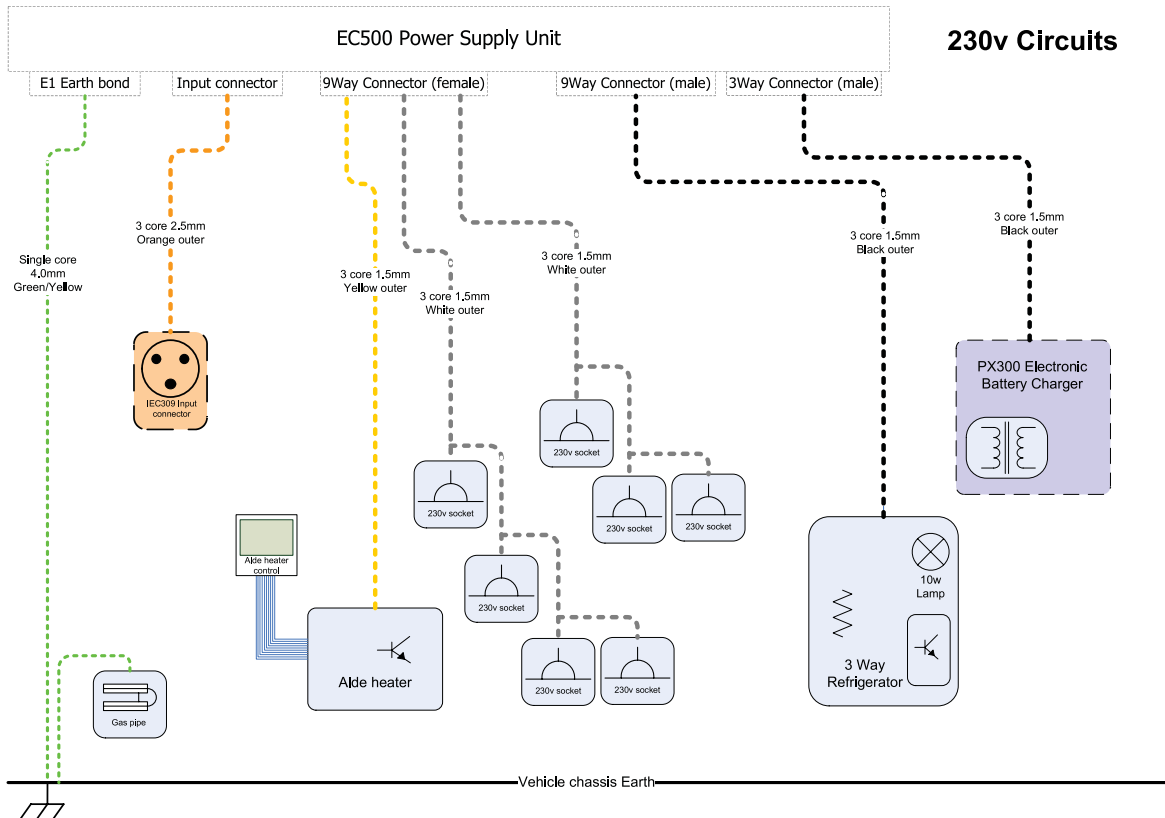



CLUBMAN - DELTA



Y/U

Example

Yellow cable with Blue stripe

Cable Colour Chart

12v Cable Colours

B	BLACK
N	BROWN
R	RED
O	ORANGE
Y	YELLOW
G	GREEN
U	BLUE
P	PURPLE
S	SLATE GREY
W	WHITE
K	PINK

230v Cable Colours

B	BLACK
N	BROWN
W	WHITE
O	ORANGE
Y	YELLOW
G	GREEN
U	BLUE



GENERAL DATA

ARIVA, QUASAR, STELLAR & LEXON

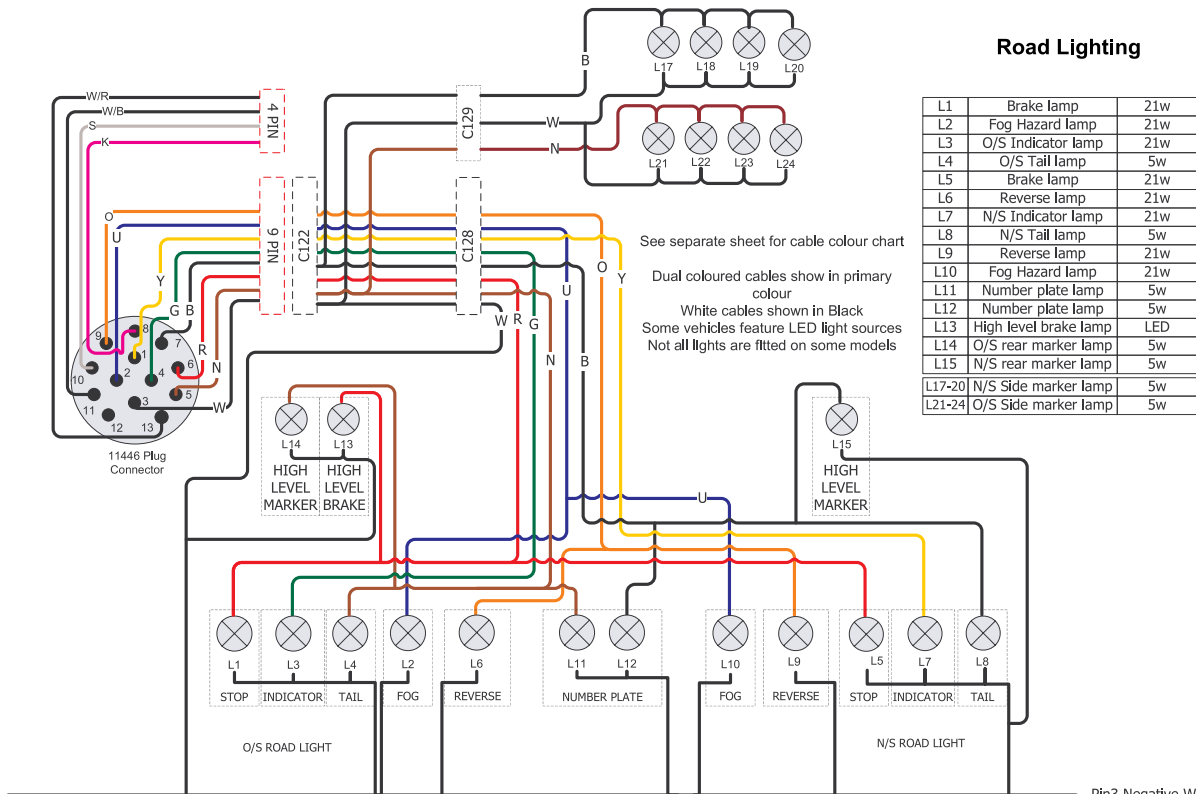



ARIVA, QUASAR, STELLAR & LEXON

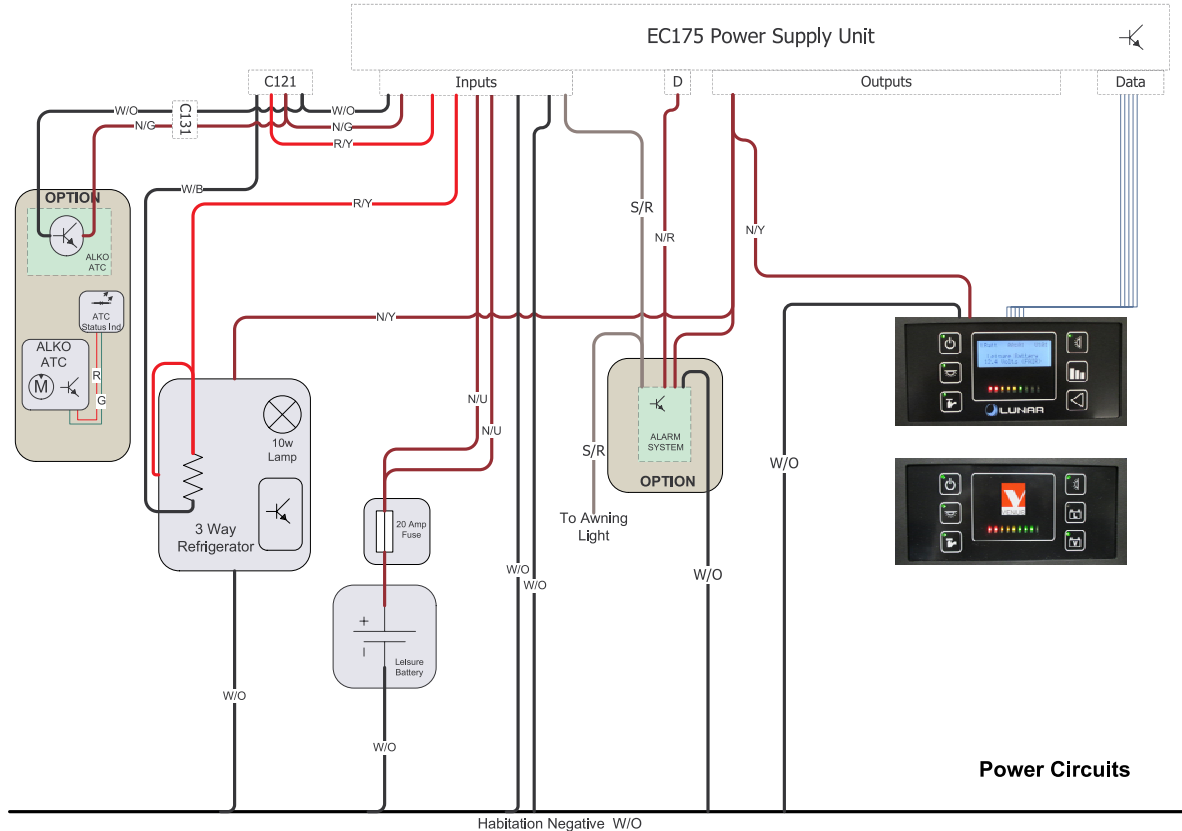



GENERAL DATA

ARIVA, QUASAR, STELLAR & LEXON

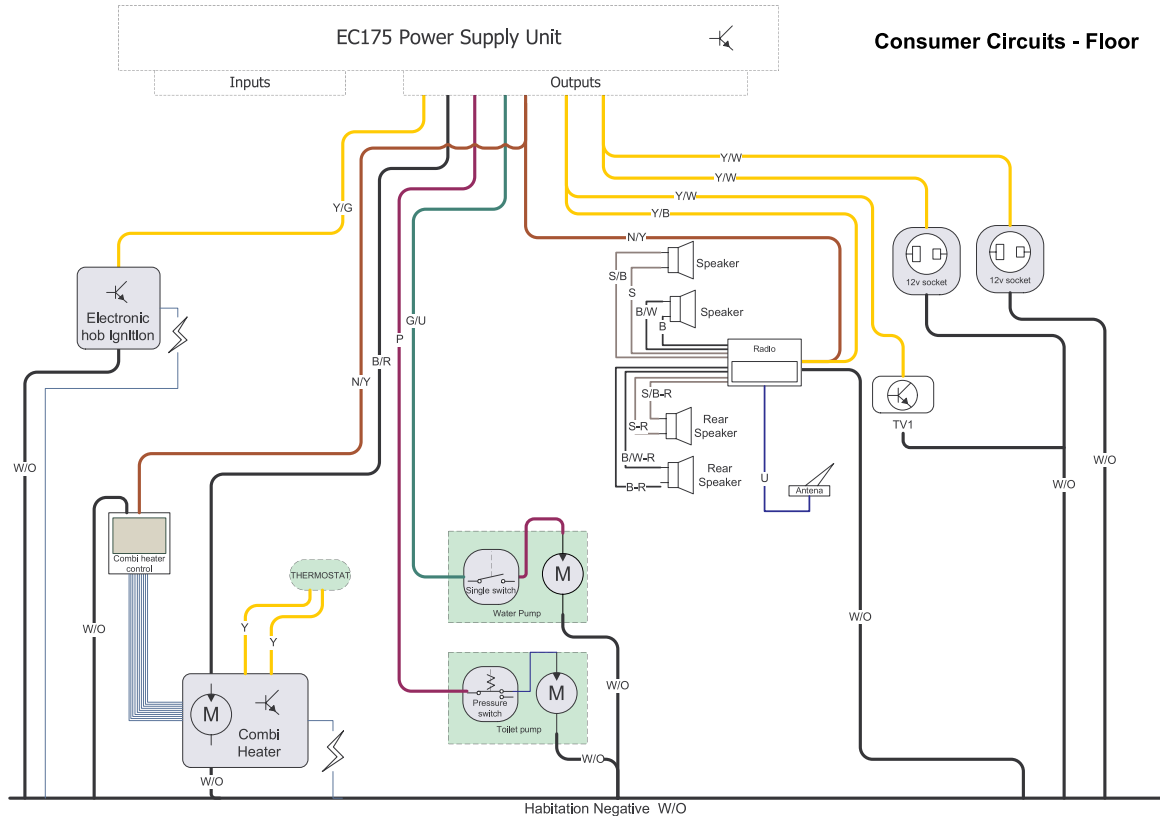



GENERAL DATA

ARIVA, QUASAR, STELLAR & LEXON

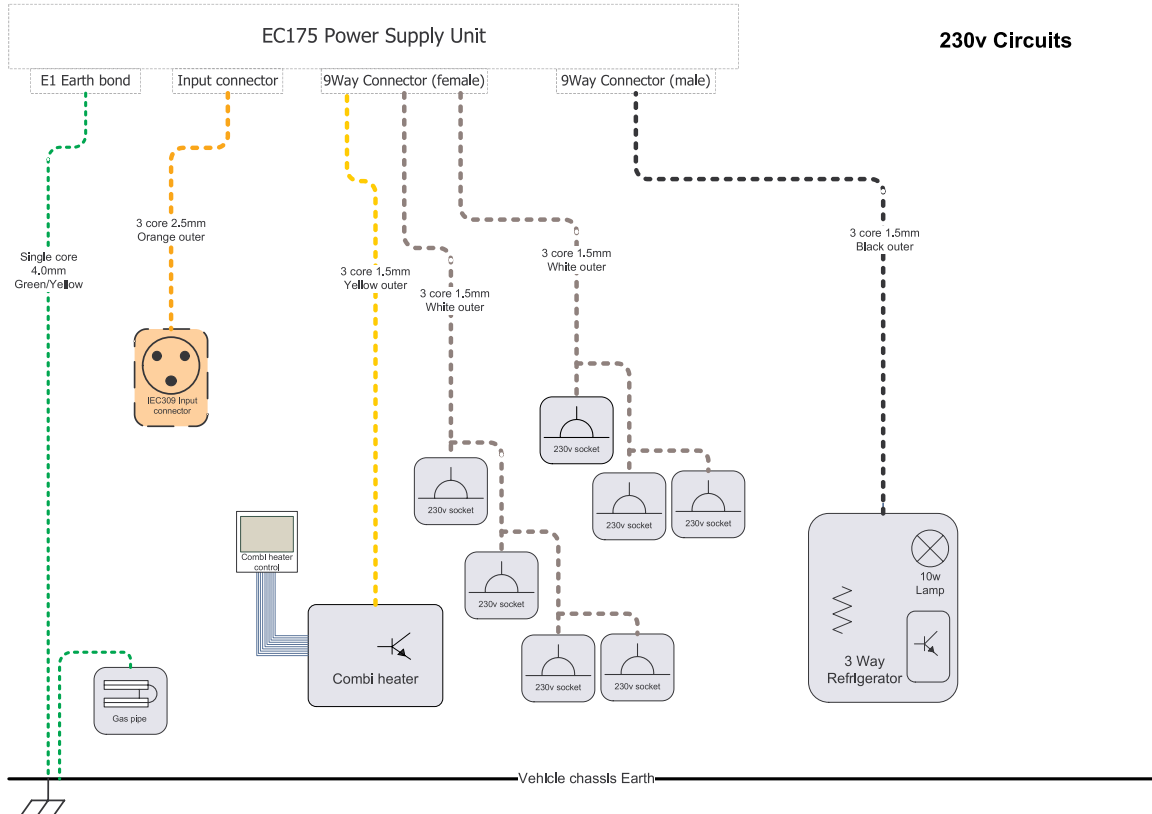



ARIVA, QUASAR, STELLAR & LEXON

Example



Y/U

Yellow cable with Blue stripe

Cable Colour Chart

12v Cable Colours

B	BLACK
N	BROWN
R	RED
O	ORANGE
Y	YELLOW
G	GREEN
U	BLUE
P	PURPLE
S	SLATE GREY
W	WHITE
K	PINK

230v Cable Colours

B	BLACK
N	BROWN
W	WHITE
O	ORANGE
Y	YELLOW
G	GREEN
U	BLUE



GENERAL DATA

LIGHT BULB REPLACEMENT

Brake/side light	Twin 21W/5W, 12V
Front side light	5W, 12V
Side light (white/red)	5W, 12V
Indicator light	21W, 12V
Reversing light	21W, 12V
Fog light	21W, 12V
High level brake light	12V LED
Number plate light	5W, 12V
Mains Reading Light	12V LED (None replaceable bulb)
Ceiling Light	12V LED (None replaceable bulb)
Toilet ceiling light	12V LED (None replaceable bulb)
Awning Light	12V LED Strip (None replaceable bulb)
Cocktail Cabinet	12V LED (None replaceable bulb)
Spot light	12V LED (None replaceable bulb)
Mood light 195mm	12V LED Strip (None replaceable bulb)
Bunk light	12V LED (None replaceable bulb)
Courtesy light	12V LED (None replaceable bulb)
Reading lamp	12V LED (None replaceable bulb)
Front interior corner light	12V LED (None replaceable bulb)

SECURITY

Ensure that you lock all windows and doors when leaving your caravan. Fit a towbar hitch lock or a wheel clamp -consult your dealer on all safety and security recommendations.

Keep your gas cylinder locked when leaving your caravan.

Many devices are available to alarm your caravan. It is a good idea to mark your caravan in a secret place -this will help the police to identify it should it be stolen.

Caravans can be stolen from storage compounds, motorway service areas and even your own premises, so it is always wise to be vigilant at all times. Ask your dealer about details on all security aspects.



LUNAR OWNERS CLUB

Now you are the owner of a Lunar caravan why not join the Lunar Owners Club.

This is an independent club run and organised by owners.

Lots of opportunities exist to make new friends at social gatherings and Rallies both Regional and National.

A leaflet regarding the Owners Club is within the wallet, if it is not please contact Lunar and a copy will be sent to you.

Alternatively for further information please visit the Lunars Owners Club website at: www.lunarsownersclub.net

OWNERS WARRANTY

All Lunar Caravans are supplied with a 6 year body shell warranty and a 3 year manufacturer's backed warranty from the date of purchase. The warranty is conditional on annual servicing being carried out within 60 days either side of the anniversary of the purchase date, except the third service which should be carried out prior to the third anniversary date of the final year.

Validating your warranty

To validate your warranty, you simply need to register your caravan purchase with us at www.lunarcaravans.com. By registering your details we will be able to assist you more easily should you make a warranty claim.

Before you register please make a note of your caravan's 17 digit VIN Number and your 3 digit Registration Security Number.

The VIN number, beginning SGL, can be found on the windows. The Registration Security Number can be found on the Thetford Model Label located inside your fridge or oven. The Model Label has a Serial Number or SER. NO. and the **last 3 digits** of this number will form your Registration Security Number.

Please note that your oven and fridge will have different Serial Numbers to each other, but you can use the last three digits from either one to register your van.

Once your details have been submitted, you will be sent email confirmation that they have been successfully received.

Additional equipment

If additional equipment (other than those on the optional list of Lunar) is to be fitted you should check with your dealer beforehand. The warranty may be invalidated.

Vermin

Vermin can gain access via the smallest of holes. Lunar fit grills and grommets to prevent this but the nature of some caravan storage means it can happen, with upsetting results. We advise setting a trap and/or poison and regular inspection.

Vermin damage is not covered by warranty.



GENERAL DATA

CRiS

CRiS is the Central Registration & Identification Scheme that issues touring caravan registration documents, equivalent to that of the V5 registration document issued by the DVLA for cars. CRiS was established in 1992 by The National Caravan Council and provides a method of registering the 'keeper' details of every tourer manufactured by NCC member companies to help prevent and detect caravan related crime.

Why register with CRiS?

- Safety
- Security
- Warranty

Did you know...?

- You should not take a tourer abroad without a registration document. If you go abroad your CRiS registration certificate provides the necessary proof, required by the police and other authorities, that you are its registered keeper.
- If you need to make a claim on your insurance, CRiS can help speed up claims by providing details of your tourer and its purchase date to relevant parties.

- CRiS can help your tourer's manufacturer contact you in the event that there is any kind of product recall or fault that could affect the safety of your caravan.

For help, support and advice, contact CRiS:

NCC CRiS Ltd
PO Box 445
Aldershot
GU11 9SF
Tel: 0203 282 1000

www.cris.co.uk

Opening hours: Monday – Friday 8am to 8pm
Saturday 9am to 5pm
Sunday 10am to 5pm.



CARAVAN WINTERIZATION GUIDE

If the caravan is to be stored for any length of time, the following procedure is advisable:

1. Location

If possible avoid siting the caravan beneath trees or near dilapidated buildings, where strong winds may dislodge branches or slates that can damage the caravan. In exposed conditions ground anchors may be advisable. Be wary of low lying areas that may be prone to flooding.

2. Covers

Large polythene or tarpaulin sheets should not, in the opinion of most experts, be used to 'seal' the caravan against the elements. Condensation and mould growth may be encouraged and any flapping material or guy ropes could scratch acrylic windows.

If you feel a cover is absolutely necessary because of where the caravan is parked, purchase one that is made of "breathable" material.

3. Ventilation

Caravan vents should be left uncovered to provide adequate air circulation inside the caravan; however if in an exposed or salty location the vents on the side of the prevailing wind and/or the 'fridge vent may be closed off for the winter. If you have

regular access to the caravan, you could place some moisture absorbing crystals in cupboard corners to reduce the risk of condensation, but these will require fairly frequent changing.

4. Interior

To prevent possible mould growth over the winter, clean and vacuum carpets, curtains and upholstery and if possible remove the soft furnishings and store in a warm, dry place (eg attic). If not possible to remove the cushions, store on edge away from the caravan walls, allowing air to circulate around them and cover with an old sheet to prevent fading in the sunlight.

Walls and ceilings should be wiped over with a mild anti-bacterial solution (eg Dettol) and can be polished afterwards if desired. Cupboards should be emptied, cleaned and vacuumed out. Small doors can be left ajar to assist ventilation, but larger doors should be closed or they may warp.

The refrigerator should be emptied, cleaned with a solution of bicarbonate of soda or anti-bacterial solution and the door left ajar.

The hob/oven should be thoroughly degreased and cleaned. If using one of the stronger oven-cleaners on the market be sure to allow plenty of ventilation whilst working. If necessary burner jets can be

brushed over with a stiff brush, and blockages cleared with a high-pressure air line. Never try to clear blocked jets with a piece of wire which can damage or enlarge jet holes.

Water heaters must be drained and care must be taken to remove any lurking pools of water or frost damage may result. If possible blow air through the heater to push any water droplets through. Leave drain taps and inlets open.

The water pipes can be flushed through with a proprietary sterilising agent and the waste pipes with a stronger disinfectant. Make sure the water pump is drained and remove the water filter. Fresh and waste water containers should be cleaned, drained and stored with caps loose or off. Leave all water inlets and outlets open, but they may be covered with a fine mesh material (eg stocking) to prevent entry of insects etc.

The toilet should be cleaned according to the manufacturer's instructions, using a suitable disinfectant for the holding tank. Rinse all sections thoroughly and store unsealed. Any rubber seals or diaphragms can be lubricated with olive oil to prolong life.

5. Battery

Unless powering an alarm system, the 12v battery should be removed, wiped over, the terminals cleaned and smeared with



GENERAL DATA

petroleum jelly. The electrolyte level should be checked and topped up with distilled water if necessary. Trickle charge from the mains until you obtain a reading of 12.6v on a voltmeter or 1.27 on a hydrometer. Store the battery in a cool, dry place and check the state every 6-8 weeks. Top up the charge as required.

Electric clocks, smoke detectors etc, if fitted, should have their internal battery removed. Battery powered burglar alarms may benefit from a new set of batteries for the winter.

6. Awning

The awning should be spread out on dry grass or concrete and brushed with a broom to remove any mud. If the canvas is stained try removing the marks with a stiff brush and plain water. If this fails pure soap flakes can be tried, which will mean re-proofing is necessary afterwards, but never use detergents. If stains are stubborn there are proprietary cleaners such as Fabsil Universal Cleaner, available from caravan accessory shops, or contact Grangers International Tel: 01773 521521. Any mildew spots can be treated with a weak solution of hydrogen peroxide – scrub into the affected area and allow to dry before re-proofing (spot test a hidden area in case colour is affected). Such severe treatment will weaken the awning material so live with stains if you can! Clear windows can be cleaned with methyated

spirits if water doesn't work, but nothing stronger. Examine seams and repair any broken stitching and replace perished rubber tensioners. Give the awning a good shake and pack it when completely dry, trying not to put too many creases in the window. Store in a dry, vermin free area.

Awning poles need little attention other than a wipe down with a damp cloth. Don't oil or grease them as this may get onto the canvas. Pegs can be cleaned and straightened and any badly damaged ones can be replaced ready for the next season.

7. Exterior

Your caravan is constructed through the use of several types of materials, paints and coatings in the course of manufacture. Side walls have strengthening inserts in areas which are painted or coated, such materials vary in their make up and over time react differently in opposing areas to atmospheric, chemical and UV influences.

In some instances this can result in a yellowing or matting of components and finishes to varying degrees. This UV or chemical yellowing in no way compromises the usability or performance of the product and if desired, in most cases, can be restored by polishing with a compound such as T-Cut (always follow the manufacturers recommended guidelines). The caravan will

also benefit with regular thorough cleans with a car wash wax type of shampoo.

Look over the rubber window seals and replace any that look perished. Coat serviceable rubbers with olive oil. If you have a damp meter check around the inside for any trouble spots and re-seal suspect joints. Any major damp penetration problems should be resolved before storage. Minor leaks might be cured using Captain Tolley's Creeping Crack Cure. Major leaks require complete renewal of the sealant; both products should be available from caravan accessory shops.

8. Chassis

The chassis should be brushed off, or if exposed to corrosive elements, eg road salt, thoroughly washed down. Any surface rust can be removed with a wire brush or sandpaper and the chassis and axle tube can be painted with a rust inhibitor, suitable paint (eg Hammerite) or Finnigan's Waxoyl. The coupling and all winding mechanisms should be degreased, examined for wear then re-greased.

9. LPG cylinders

LPG cylinders should be removed and stored in a cool, ventilated location. Some storage compounds will insist they are removed to



comply with fire safety regulations. The regulator and/or pipe end can be covered with a stocking or similar to prevent the entry of debris or insects that can block the gas supply.

10. Electrics

13 pin, 12N and 12S plugs should be inspected and cleaned and the pins coated with vaseline. WD40 should not be used as it may 'melt' some plastics on contact. The plugs should be protected from the weather but not fully sealed in polythene which will encourage condensation. Road lights should be checked and any water ingress cured, full inspection and cleaning can be done now or left to the springtime service.

11. Axle stands

Ideally the caravan should be jacked up and supported on axle stands with the wheels clear of the ground. Wheels can be removed if desired and stored in a cool, dark place at normal inflation pressure. Inspect tyres carefully and make a note to renew any suspect ones before using the caravan again. The corner steadies should be lowered and rested on blocks if they do not reach the ground. The handbrake should be left off and the wheels rotated from time to time to keep the bearings lubricated.

12. Security

Finally remove any valuables and documents from the caravan to make it secure; thieves do not hibernate for the winter!

Please note that neither Lunar Caravans Ltd nor The Caravan Club endorse any of the listed products and you should satisfy yourself as to their suitability. As always, check that the installation of an after-market accessory does not invalidate your warranty.



NOTES

Publication Designed and Produced by Preset Graphics Ltd
Tel: 01332 549278. Fax: 01332 549279. E-mail: Presetgraphics@btconnect.com
Ref: 21389 © All Rights Reserved