

CONTENTS

- Introduction 1
- Technical Information 2
- Motorhome Code 3
- Preparing for the Road 4
- On the Road 5
- Arrival on Site 6
- Fire & Safety 7
- Services 8
- Wiring Diagrams 9
- Equipment Details 9
- Motorhome Care 10
- Motorhome Warranty 11
- Change of Ownership 13
- Annual Habitation Service Record 14
- Index 15

INTRODUCTION

Thank you for deciding to buy one of our new Motorhomes. This handbook tells you how to look after your Motorhome so that it may give you years of pleasure and enjoyment.

Remember that it is a vehicle and thus calls for a small amount of regular maintenance.

You are requested to contact your dealer on all enquiries in order to ensure satisfaction.

The serial number of your Motorhome should be quoted in all correspondence, it can be found on the driver's side door pillar.

There is also a Renault serial number on the driver's side door pillar which should be quoted in any communications with Renault.

Technical Approvals

The Roadstar has been European Commission Whole Vehicle Type approved via the Vehicle Certification Agency (VCA) to ensure your new Motorhome is compliant and safe to use.

Security

The theft of a Motorhome can occur in the most unlikely circumstances; from a motorway service area or even an owner's driveway. Secure all windows and doors when your Motorhome is unoccupied even if only for a short time.

Record the Motorhome serial numbers in a safe place away from the Motorhome.

Please note: Product information within this document is correct at the time of going to print. In the interest of continual product development, equipment and specification changes may take place during the course of a model year.

TECHNICAL SPECIFICATION

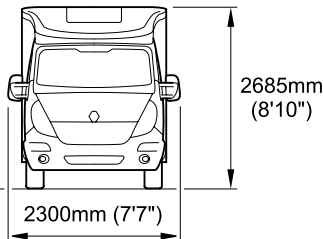
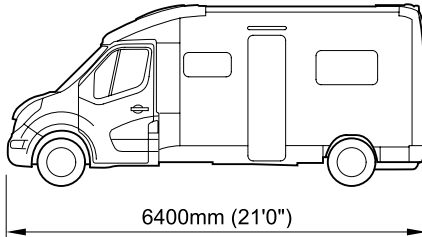
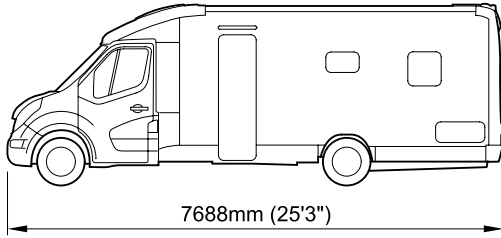

Chassis

Renault Master 2.3dcl (13 OPS)

Model	Roadstar TI	Roadstar EL	Roadstar EB	
No. of berths	4	2	4	
Exterior length	7688mm/25'3"	6400mm/21'0"	7688mm/25'3"	
Overall width (including awning light)	2300mm/7'7"	2300mm/7'7"	2300mm/7'7"	
Overall height	2685mm/8'10"	2685mm/8'10"	2685mm/8'10"	
Max. head room	2000mm/6'7"	2000mm/6'7"	2000mm/6'7"	
MRO	3294kg	2895kg	3294kg	
Max. User Payload	506kg	522kg	506kg	
Max. Technical Permissible Laden Mass	3800kg	3500kg	3800kg	
Thermal Insulation Grade = 3				
Bed sizes	Front Double	2100 x 1340mm 6'11" x 4'8"	2100 x 1340mm 6'11" x 4'8"	
	Rear Double	1830 x 1340mm 6'0" x 4'8"	2110 x 1820mm 6'11" x 6'0"	2100 x 1270mm 6'11" x 4'2"
	Rear Single 1		1820 x 730mm 6'0" x 2'5"	1820 x 730mm 6'0" x 2'5"
	Rear Single 2		1820 x 730mm 6'0" x 2'5"	1820 x 730mm 6'0" x 2'5"

* If base vehicle varies from base specification, please refer to manufacturers handbook.

TECHNICAL SPECIFICATION

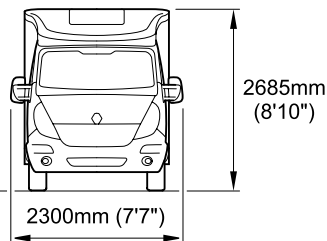
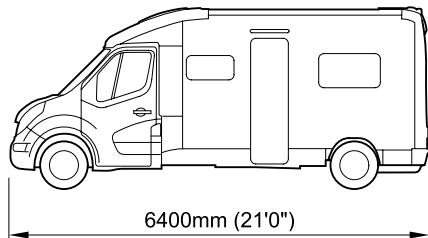
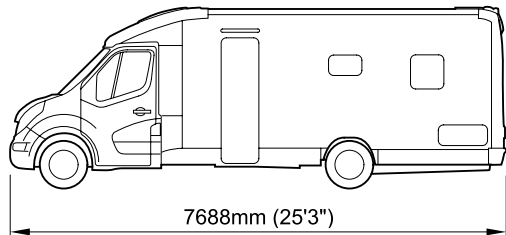

Chassis

Renault Master 2.3dcl (13 OPS)

Model	Cassini TI	Cassini EL	Cassini EB	
No. of berths	4	2	4	
Exterior length	7688mm/25'3"	6400mm/21'0"	7688mm/25'3"	
Overall width (including awning light)	2300mm/7'7"	2300mm/7'7"	2300mm/7'7"	
Overall height	2685mm/8'10"	2685mm/8'10"	2685mm/8'10"	
Max. head room	2000mm/6'7"	2000mm/6'7"	2000mm/6'7"	
MRO	3294kg	2849kg	3294kg	
Max. User Payload	506kg	568kg	506kg	
Max. Technical Permissible Laden Mass	3800kg	3500kg	3800kg	
Thermal Insulation Grade = 3				
Bed sizes	Front Double	2100 x 1340mm 6'11" x 4'8"	2100 x 1340mm 6'11" x 4'8"	
	Rear Double	1830 x 1340mm 6'0" x 4'8"	2110 x 1820mm 6'11" x 6'0"	2100 x 1270mm 6'11" x 4'2"
	Rear Single 1		1820 x 730mm 6'0" x 2'5"	1820 x 730mm 6'0" x 2'5"
	Rear Single 2		1820 x 730mm 6'0" x 2'5"	1820 x 730mm 6'0" x 2'5"

* If base vehicle varies from base specification, please refer to manufacturers handbook.



CODE OF CONDUCT

CAMP SITES

Arrivals

Report to reception immediately on arrival.

Vehicle Movement

Keep to roadways unless otherwise directed.

Adhere to speed limits set by the campsite. (Remember that the stopping distance on grass is considerably greater than on tarmac).

Only a person in possession of a current driving licence may drive on the site.

Park correctly as advised on your pitch. Where possible leave 20ft of free space around your vehicle.

Use of Site Appliances

Use the electrical mains hook-up in the correct manner and with caution.

Ensure that all fresh water taps/connections are turned off after use.

Have care and consideration when using all facilities (toilets and showers etc.) and leave them clean and tidy. Young children should be escorted.

Waste Disposal

If the vehicle is not fitted with a waste water tank, a suitable receptacle should be placed below all waste water outlet pipes. Do not let these containers overflow.

Empty/dispose of all waste water where instructed.

To avoid possible damage to sewage purification works, only approved chemical fluids must be used. Under no circumstances may coal tar, phenol or caustic-based fluids be used.

Disposable napkins and similar bulky items must not be put into chemical closet emptying points but should be wrapped in a polythene bag and placed in the container provided.

Put all litter in containers marked for the purpose.

Noise

Do not make excessive noise.

Flying kites, model aircraft and the use of items like catapults or airguns as well as ball games should not be permitted among, or close to caravans or motorhomes.

Musical instruments, record players, radios and televisions should not be used to the inconvenience of other people on site.

Open and close doors quietly.

Power generators must be adequately silenced and used with consideration.

Dogs and Pets

All dogs and other pets should be kept under control.

Unless permission has been granted no animal should be allowed loose on the site and leads must not exceed 10ft.

No Animal should be allowed in the shower/toilet blocks.

Do not let dogs foul the site.

Fire Precautions

Adhere to and make note of all fire precautions concerning the whereabouts of the fire points.

Although not compulsory it is recommended that a 1 x 2kg dry powder fire extinguisher is carried. It should comply with BS 5423 and be marked BSI or FOC approved. It is important to check at regular intervals that the extinguisher is working as is required of types meeting BS 5423. Careful thought is necessary for the positioning of the extinguisher, which should be near the door but not too close to the cooking equipment where sudden flames could make it unreachable. In the kitchen area a fire blanket is a worthwhile precaution.



MOTORHOME CODE

Unless permission has been granted barbecues should not be used. When permission has been granted, consideration should be given to the annoyance that can be caused to other users of the site.

Open fires are not allowed.

Awnings & Tents

Awnings and tents should only be used when permission has been obtained.

When on grass and staying for more than a few days the ground sheet and/or side flaps of awnings should be periodically raised in order to avoid damage to the ground.

Departure

Leave the pitch clean and tidy.

On leaving, check out with reception, paying the required dues.

Parking

Motorhomes should only be parked in approved places.

When using the facilities of a Motorhome at such times care and consideration should be given to other road users.

In the event of a Motorhome travelling slowly and there being a queue of traffic behind, the driver of the Motorhome should, where possible, pull over in order to let the other traffic pass.

When the vehicle is in motion it is compulsory that all passengers are seated and seat restraint straps worn.

Exterior steps should be properly retracted and secured.

When the vehicle is being refuelled, or on a ferry, all gas systems must be turned off.

Gas appliances should only be used when the vehicle is in motion when such use is permitted by the manufacturer of the appliance.



YOUR MOTORHOME (Weights explained)

Mass in Running Order (MRO)

The weight of your Motorhome as it leaves the factory, as new with standard fixtures and fittings, plus an allowance for driver and 90% fuel.

Maximum Technically Permissible Laden Mass (MTPLM)

The maximum weight of the vehicle when fully laden for use on the road. See specification section for actual figure.

User Payload

The load margin (payload), this represents the difference between the Mass in Running Order (MRO) and the Maximum Technically Permissible Laden Mass (MTPLM). It shows the maximum weight which can be loaded into your Motorhome, covering items such as food, crockery, cutlery, clothing, bedding, gas cylinders, etc. See Technical Specification for the actual figure.

Please take care to ensure that you have allowed for the masses of all items you intend to carry in the Motorhome, e.g. passengers, optional equipment, essential habitation equipment and personal effects such as clothing, food, pets, bicycles etc.

LOADING AND DISTRIBUTION OF WEIGHT IN THE MOTORHOME

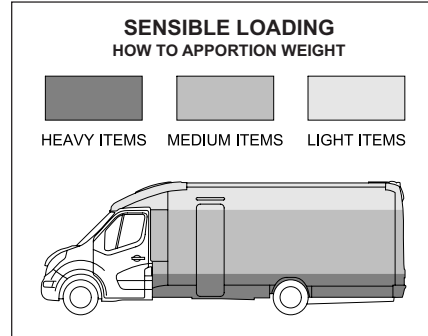

Loading

Correct weight distribution is a major factor in making your Motorhome a balanced and pleasant vehicle to drive without compromising road-holding. Care should therefore be taken to ensure that heavy items are well spaced and are in as low a position as possible, for example, low cupboards and bed boxes.

DO NOT EXCEED THE STATED MAXIMUM LOAD. ITEMS FITTED OTHER THAN STANDARD EQUIPMENT WILL DEplete THE PAYLOAD STATED IN THIS HANDBOOK.

WARNING: Under no circumstances should the maximum permissible laden mass of the Motorhome be exceeded.

Before Moving Off

Whenever making a journey with your Motorhome, either setting off on holiday or returning home, it is good practice to run through this simple checklist.

1. Close and secure all cupboards and drawers and check any loose articles.
2. Make sure heavy articles are stored in accordance with the loading procedure. Do not store tins, bottles or heavy items in the roof.
3. The main table should be stored in its transit position.
4. Leave all blinds open and remove all cab screens to aid visibility.
5. Check that gas cylinders are correctly positioned, securely fastened and turned off.
6. Check that all gas-operated appliances have been isolated, including the hob and oven.
7. Ensure there is sufficient gas to meet your needs.
8. Check the fridge is on 12V operation and the door is locked. (Note: the electrical relays will allow the fridge to be run on the vehicle battery when the engine is running).
9. Switch off 230 volt supply at source, disconnect mains cable from vehicle. Beware of potential electric shock from wet cable. Coil cable and store in a safe place.



PREPARING FOR THE ROAD

- Check that the 230 volt mains input socket flap is securely closed.
10. Check your RCD's/MCB's for operation.
 11. Check and if necessary, charge the conversion battery.
 12. Check that the battery is secure and that the battery box lid is fastened.
 13. Ensure that your fresh water tank and waste tank are empty during transit and that your drain cap is closed.
 14. Check your external rear view mirrors and adjust if necessary.
 15. Referring to your base vehicle manual, check all fluid levels including automotive fuel. Also check wheel nuts are secure and tyre pressures are correct.
 16. Check underneath the vehicle for stray items.



DRIVING YOUR MOTORHOME

Always be conscious to adhere with speed limits in force, your Motorhome can be driven up to 70 mph on motorways and 60 mph on dual carriageways.

Reduce Speed

- In high or cross winds
- Downhill
- In poor visibility.

Driving

- Do not bump the kerb.
- Allow longer to get up to speed and pass.
- Do not swing out suddenly.
- Carry out all manoeuvres as smoothly as possible.
- Use the nearside wing mirror to check that the Motorhome has fully cleared a vehicle when overtaking.

Whilst the vehicle is being driven please ensure that:

- Both the driver and passengers wear seatbelts. This is a legal requirement.
- Heavy loads are not stored in areas from which they may become detached. Please ensure that heavy items are stored low down and take care not to

overload individual wheels, the axles or the MTPLM. Refer to Page 4-1, 4-2 for loading information.

- Tables are secured in their storage compartments and all top extensions are lowered.
- Cupboards and flaps are in the closed position and secured.
- The refrigerator door is closed and secured.
- All passengers are secure and wear the appropriate restraint for their height and age.

Wheels

In the event of a puncture, ensure that the replacement wheel is of the same construction and size as the one that is being removed. The tyre pressures must be suitable for the use to which they are being put. Please be conscious to adhere to the law and be sure your tyre tread depth does not fall under the minimum requirement set. The correct tyre pressures are displayed on the inside of the driver's door.

Dedicated travelling passenger seating

Seat belts are fitted to all travelling seats. Each seatbelt frame is tested to the relevant safety requirements.

Never travel in or attempt to install a seatbelt to a non-designated seat.

Child seats

Positioning/ Fitting

Dependent upon the child seat type, the most suitable position for a child seat to be fitted may be the front passenger seat of the cab (NOTE Follow the airbag advice) or the window seat of the forward facing rear seat. Advice should always be taken from the retailer on the suitability and security of the seat in the Motorhome.

Read and follow the child seat manufacturer's instructions for fitting the seat.

All of the Motorhomes are fitted with inertia seatbelts; however, the child seat must be tight in the adult seat. Push all your weight into the child seat as you tighten the belt.

Keep a copy of the child seat fitting instruction in the Motorhome for easy reference.



ON THE ROAD

Airbag

Never fit a rear-facing child restraint in a seat with an active airbag in front of it. Airbags are fitted as standard in front of both the driver and the front seat passenger.

Forward-facing child restraints should be positioned as far back from the airbag as possible. Check the base vehicle handbook.

Habitation area seatbelts

Inset the buckle into the plug in socket until it clicks. The clicking noise will indicate a correct assembly.

Releasing the seat belt:

Press the red release button; the buckle will be ejected from the plug in socket.

- The belt is designed for one person and must not be put around a child seated on someone's lap.
- The belt is suitable for retaining most child seats and boosters.
- Never wear a slack seatbelt.
- When installed correctly the seatbelt should pass across the centre of the shoulder and fix into the plug in socket beside the hip.
- It is important that the strap is not twisted during use as this can cause damage.
- Webbing must not be allowed to rub against sharp surfaces as this could lead to strap damage. If a belt is showing signs of wear (frayed, damaged or stressed) it should be replaced.

- Always replace a seatbelt after an impact.
- Always check the anchorage points after an impact; if these are deformed the seatbelt frame will need to be replaced.
- Never modify the belt.
- Inspect your seatbelt on a regular basis.
- The belt should always be used according to these instructions and adjusted to fit.

ARRIVAL ON SITE

Positioning the Motorhome

Keep to the roadways unless otherwise directed. Adhere to speed limits. (Remember that the stopping distance on grass is considerably greater than on tarmac).

Only a person on possession of a current driving licence may drive on the site.

Selecting a pitch

Do not pitch in such a position that your Motorhome will obstruct others coming in. Try to choose an area which is reasonably level, dry and preferably with a hard base. If you have no alternative but to pitch on a slope try to ensure that you are facing down the slope, for ease when leaving.



SAFETY

Important: your attention is drawn to the notice fixed in your Motorhome advising on fire protection, ventilation and what to do in case of fire.

Children

Never leave children alone in the Motorhome and keep potentially dangerous items out of reach as at home e.g. matches, drugs etc.

Fire Extinguishers

It is recommended that a 1Kg (2.2lb) minimum capacity dry powder fire extinguisher be located near to the main habitation entrance door.

A pan fire should not have a fire extinguisher aimed at it but be smothered with a fire blanket. This should be within easy reach of the hob but away from the source of flames.

In case of a fire

- Get everyone out of the Motorhome as quickly as possible using whichever exit is nearest including windows. Do not stop to collect any personal items.
- Raise the Alarm. Call the fire brigade.
- Turn off the gas cylinders valve if it is safe to do so.

Ventilation and Condensation

The ventilation points on your Motorhome are fixed points of ventilation which are specified by European Standards. Under no circumstances must these be blocked or obstructed. It is advised that fixed ventilation points and any protective screens are checked and cleaned (if necessary) on a regular basis.

Fresh air circulation should be allowed below the Motorhome when appliances are in use and when flues terminate below the floor to allow free evacuation of the products of combustion. At least three sides of the under-floor space should be kept clear and unobstructed, including by snow. Do not make any additional openings in the floor.

ELECTRICAL SYSTEMS

Batteries

Battery terminals and connectors should be firmly attached. Battery surfaces should be free from moisture and dirt.

Where removable cell caps are fitted they must be screwed firmly home.

When removing a battery always remove the negative cable first. On re-connection the negative cable should be connected last. Switch off all lamps and appliances before disconnecting the battery. Do not smoke while working on or near a battery.

Fuses

Always replace blown fuses with one of the correct rating.

Overload

Never overload any electrical circuit, especially the 12 volt socket outlet. The rating of appliances should be checked before connection. The permitted current draw is 20 amps.

Charger Unit

Keep the charger unit well ventilated and never allow material or bags to be in contact with the unit casing which gets hot when the unit is operating.

230 Volt Mains operation

Before connecting to a power supply, ensure that the contacts in both the plug and the socket are clean and dry and that the hook up plug is firmly located and locked into the socket. The PDU (Power Distribution Unit) must be easily accessible at all times.

General

Before using your Motorhome, you should be fully conversant with the following safety precautions; if you are in any doubt as to the meaning of any of them you should contact your supplying retailer. Please read the following carefully.



FIRE & SAFETY

In the interest of safety, replacement parts for appliances must conform to the manufacturer's specifications and should be fitted by them or an authorised agent.

- Never use portable cooking or heating equipment other than electric heaters that are not of the direct radiant type, as it is a fire and asphyxiation hazard.
- Do not use cookers as heaters and do not dry clothes on the cooker or space heater.
- Make sure that combustible materials cannot come into contact with hot surfaces or burners.
- Surfaces of appliances may become hot in use and the guard provided does not give full protection to the young or the elderly.
- Do not use additional independent gas appliances inside the vehicle.
- Never allow modifications of the electrical or LPG systems or appliances except by qualified technicians.
- Do not obstruct ventilation.

The heating system provided in your Motorhome is of the room sealed type. Any replacement should be of the same type.

Turn off all gas cooking appliances before travelling.

Ventilation openings are located below all the gas appliances, and in the base of the gas locker. In winter conditions make sure the vents are clear of both snow and mud. These openings should regularly be checked and any mesh covering them cleaned with a stiff brush to prevent any risk of them becoming blocked. The openings are provided for your safety - please do not obstruct them.

SMOKE ALARM

The smoke alarm is operational once the battery is connected. When products of combustion are sensed, the unit sounds an alarm until the air is cleared.

Features:

- Battery Operated
- The Operating light (red LED) flashes every 40 seconds confirming that the unit is powered.
- Low Battery Warning: the unit will emit an audible 'chirp' once every 40 seconds for 7 days before the battery needs to be replaced. (Failure to replace the battery will result in insufficient power to alert you in a real fire situation.
- Sensitivity test button. This tests the sensitivity, circuitry, battery and horn.
- Loud alarm.

Test smoke operation after vehicle has been in storage, before each trip and at least once a week during use.

Your alarm requires one 9 volt battery. Under normal use, the battery should last one year.

Simple Maintenance

Clean your smoke alarm once every three months to help keep the unit working correctly. Gently vacuum using the soft brush attachment.

Problems are indicated by two events:

- The alarm does not sound upon pressing the test button.
- The operating light remains steadily on or off (i.e. does not flash every 40 seconds, when the unit is not in alarm.)

Try the following:

- Inspect for obvious damage.
- Check that the unit contains recommended battery type.
- Check that the battery cover has been removed.
- Check that the battery is properly connected.
- Gently vacuum as recommended above.
- Replace battery.

If these procedures do not correct the problem, **DO NOT** attempt repairs; replace the smoke alarm.



CARBON MONOXIDE ALARM

A Fire Angel CO-9B battery operated alarm is fitted near to the ceiling in your Motorhome.

Features:

- An advanced electrochemical sensor designed to accurately measure low levels of carbon monoxide (CO) providing an early warning of toxic CO levels in your Motorhome.
- Detects carbon monoxide continuously.
- Resistant to false alarms caused by usual household contaminants.
- Sounds a large 85 dB alarm (at 1 metre (3 feet)) to alert you in case of an emergency.
- Test/Reset button.
- Simple to mount, portable, ideal for travelling.
- Conforms to the British standards Institute (CSI) Carbon Monoxide Standard BS EN 50291: 2001.
- 7 Year Warranty.

Test/Reset button feature

- Test the sounder, batteries and circuitry.
- Allows you to test the sensor by introducing a source of CO into the detector.
- Silence the loud 85dB sounder during an alarm (only possible when current CO level is less than 50ppm)

Testing the sounder batteries and circuitry

- Test the sounder, batteries and circuitry by pressing and holding the Test/Reset button for 1 second to confirm that the detector is operating properly. The sounder should sound as soon as the button is pressed, and the alarm LED will illuminate red, indicating that the sounder is working and the batteries are providing power to the unit. The test for the sounder batteries and circuitry should be performed weekly.

Testing the Sensor

- All sensors testing should be carried out by a responsible adult. This test should only be performed once a month. Excessive testing will cause the battery life to be shortened.

CO testers may be used in order to avoid having to burn cigarettes, incense sticks etc.

Please read all steps thoroughly before attempting to test your alarm.

- If the alarm is wall mounted, remove by unhooking the unit from the wall fixing screws.
- Cover the sounder vents with one hand and hold the Test/Reset button down with your thumb/ finger until the power LED illuminates green and the sounder sounds for a second time. (This should happen after 5 seconds.) Release the Test/Reset button and the power LED will flash green once every second. This indicates that the

sampling rate of the detector has increased and can be tested using a known source of CO.

- Light an incense stick or a cigarette using a match or a lighter. If using an incense stick, be sure to blow the flame out so that the incense stick is smouldering. Extinguish the lighter, or put out the match and place it into a dish of water.
- Turn the detector on its side so that the vents on the right hand side of the detector are pointing downwards. Hold the burning incense stick or cigarette around 15cm (6 inches) below the detector. An increase in the localised carbon monoxide level within the sensor to more than 50ppm (Parts Per Million, the accepted level of carbon monoxide in the air) this will cause the sounder to sound for one cycle of four loud beeps. The power LED will no longer flash green every second but will revert to flashing once a minute. The detector will revert back to the ordinary operating mode (it may take up to two minutes for the localised level of carbon monoxide to reach over 50ppm.) Now move the source of CO away from the detector as the test is finished.
- Put out the incense stick or cigarette by placing it into a dish of water. Ensure all flames have been extinguished.



FIRE & SAFETY

If the localised carbon monoxide level within the sensor does not reach 50ppm during the test, the sensor test will stop automatically after 3 minutes.

Understanding your product's indicators

The higher the concentration of carbon monoxide detected by the detector, the quicker it will respond. When sufficient carbon monoxide is detected a loud audible signal (85 dB at 1m/3 ft) will be emitted and the Alarm LED will flash red once every second.

The Alarm will sound:

- Between 60 and 90 minutes when exposed to 50ppm of CO.
- Between 10 and 40 minutes when exposed to 100ppm of CO.
- Within 3 minutes when exposed to 300ppm or more CO.
- There will be an audible 'chirp' if the battery, sensor or circuitry has any fault including a low battery. This sound will continue once a minute for 30 days. (The battery must be replaced to ensure occupant safety.)
- If the device continues to chirp despite having new batteries and the product is still in warranty then contact technical support for the device. If the device is no longer in warranty replace it immediately

Maintaining/ testing your detector

Maintenance

Your detector will alert you to potential hazardous CO concentrations in your Motorhome when maintained properly. To maintain your FireAngel detector in proper working order and to ensure that the sensors will last for the lifetime of the product, it is recommended that you:

- Test the sounder, batteries and circuitry of your detector once per week by pressing and holding the Test/Reset button for 1 second.
- Perform the sensor test annually.
- Keep the detector free of dust by gently vacuuming with a soft brush attachment when required.

To prevent the possibility of contaminating the sensor in your detector and thus affecting its reliability:

- Never use cleaning solutions on your detector. Simply wipe with a damp cloth.
- Do not paint the detector.
- Do not spray aerosols on or near to the detector.
- Do not use any solvent based products near to the detector

Failure of any test should be reported to the manufacturers technical support line.

Do not attempt to repair your CO Detector. Do not remove any screws or open the main casing of your detector. Any attempt to do so may cause malfunction and will invalidate the warranty.

Never ignore any alarm.

What to do in the event of an alarm:

- Keep calm and open all the doors and windows to ventilate your Motorhome.
- Stop using all fuel burning appliance and ensure where possible they are turned off.
- Evacuate the Motorhome leaving doors and windows open.
- Do not re-enter the Motorhome until the alarm has stopped.
- Get medical help for anyone suffering the effects of CO poisoning and advise that CO poisoning is suspected.
- Close the windows and doors and do not use the Motorhome again until you have had a full service of all appliances by your supplying retailer. In the case of gas appliances they must be tested by a certified installer. Please contact your Retailer for more details.



STANDARD WATER SYSTEM

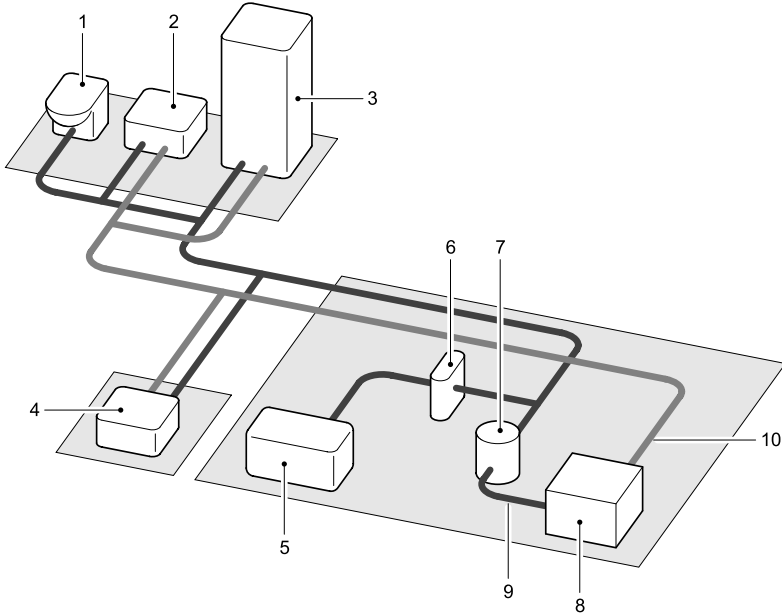

- | | |
|----------------|----------------|
| 1 Toilet | 6 Surge damper |
| 2 Sink | 7 Drain tap |
| 3 Shower | 8 Water heater |
| 4 Kitchen sink | 9 Cold in |
| 5 Water tank | 10 Hot out |

Standard Water System

All motorhomes water systems have been designed around a pump fitted within the vehicle. The pump draws water from the under floor or internal water tank, providing water pressure within the water system, when the system is switched on and water is available.

The schematic opposite shows the basic configuration of the water system.

Operation

When the pumps power supply is switched on it will draw water from the water tank and pump the water to the motorhome taps, shower, toilet and water heater.

The water pump used on the motorhome has its own pressure switch, the pump will continue to pump water until the pressure of the water on the output of the pump reaches a pre-set level. For this pressure to be achieved the taps must be closed.

When the taps are opened the water will leave the tap via the spout, the pressure between pump and tap will then be reduced. Because of this reduction in pressure the pre-set pressure level on the pump will activate the pump and draw more water to increase the water pressure within the water system.



SERVICES

As displayed on the schematic located just after the surge damper in the water system is a split which separates the water under pressure in two paths:

- 1) Through blue water pipes routed directly to the cold connection of each tap.
- 2) To the motorhomes water heater: Water from the pump enters the bottom of the water heater. Once the water fills the water heater (10 Litres) the water is expelled out from the water heater via a connection located on the top, the hot water is still under pressure and routes to the hot connection of each tap via the red water pipes.

Fresh Water System:

All fittings including the holding tank, water pipes, taps and connections are to standard BS6920 and of a food quality material, therefore, should have no effect on the quality of the water used. We recommend, however, that the system is flushed through twice before it is used for the first time. The system should always be cleaned/flushed after it has been stood for a long time. (eg over the winter period). Care has been taken to eliminate as many water traps as possible within the water system.

On filling the fresh water system always check the water source is suitable for use as drinking water. If you are filling the fresh water system using a hose pipe or water

carrier be aware to check that it is also made from non toxic materials and preferably of a food quality material.

The fresh water tank may be drained via the plug located in the base of the tank or by the drain tap situated externally. Located below the skirt at the near side rear of the vehicle.

WARNING: The fresh water system is pressured by a pump. The pump will continue to operate until it senses a pre-set pressure in the water system. If the fresh water tank has been completely emptied the pump will be unable to pressurise the system and will operate continuously. On occurrence be sure to switch the pump off using the isolator switch on the control panel until it is possible for the water tank to be refilled this will prevent damage to the water pump.

Fresh Water Tank

Your motorhome is fitted with a fresh water tank. The tank can be filled from the outside via a lockable water filler cap. On filling the water tank use a hosepipe

manufactured from non toxic material to prevent contamination of the water. If the water heater has also been drained it will require 70 litres of water to fill it.

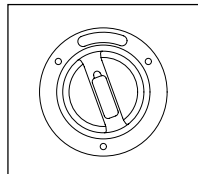

Priming the Water System:

- 1) Close the water tank drain valve.
- 2) Fill the tank with water.
- 3) Close the water heater drain valve. Open all taps except the shower tap. Mixer taps should be opened in the central position so that both hot and cold pipes are purged of air.
- 4) Be sure to locate all tap spouts over sinks.
- 5) Switch on the pump using the function on the control panel.
- 6) Turn each tap off in turn when the air is expelled and the water runs smoothly from the spout. Move mixer taps to hot and then cold to check that the air is out of both the hot and cold pipes before turning off.
- 7) Whilst holding the shower head down towards the shower drain, open the shower tap and shower head tap until all the air is expelled and the water runs smoothly, then turn the shower tap off.
- 8) Re-fill the fresh water tank with fresh water.

Please note: When priming the water system this will automatically fill the water heater with water.



Motorhome Water Tanks Locations

TI and EB Vehicles

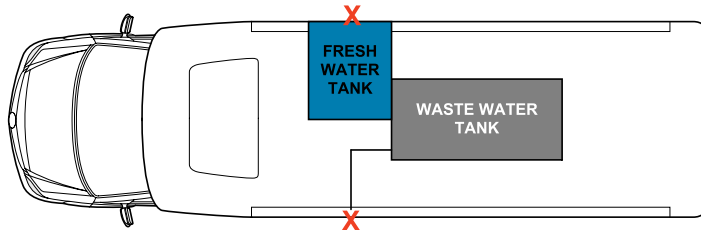

X = Location of drain tap

Note: The above diagram is representative as a guide only, the waste water tank can be positioned on the near side of the vehicle dependent of vehicle layout.

EL Vehicle

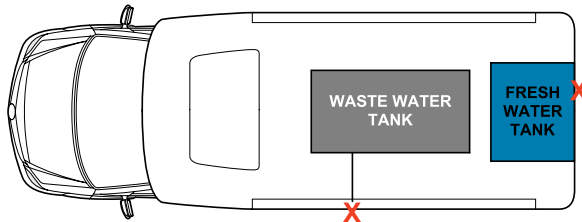

X = Location of drain tap

When opening the shower tap hold the shower head towards the drain until the water flows free of air.

Be sure that all taps are turned off when not in use (except in the event of winterising).

Note: All tanks are fitted with a breather which acts as an overflow. Overfilling the tank will result in water being expelled from the overflow outside the vehicle.

Cleaning the water system:

Your motorhome water system must be cleaned at the start and end of each season with sterilising fluid.

Sterilising:

When cleaning the water system at the start and end of each season it is advised to use a sterilising fluid..

Flush the system through to remove any effective fluid traces.

When water is first introduced to the system, or the water supply in the internal tank runs out air will be present in the system. It is important that any tap in the motorhome is ran to remove any air in the system before use. Air left in the system close to a tap can act as an accumulator and affect the ratio of hot and cold water flowing from other taps in the system.



SERVICES

System Care:

In the event of allowing water to freeze in the system this may damage the pump and plumbing in the system.

Non-Toxic antifreeze for portable water may be used for Truma pumps. Follow manufacturers recommendations.

WARNING: Automotive antifreeze must not be used to winterise the portable water systems. These solutions are highly toxic and may cause serious injury or death if ingested.

Sanitising:

The water system and water tank in motorhomes are susceptible to contamination by bacteria if correct care is not taken with the use and cleaning. Symptoms caused by bacterial contamination are not purely limited to gastrointestinal diseases; symptoms may also occur as ear, nose, throat, eye or skin infections. It is important that you carry out the following procedure prior to using the motorhome each time even if you boil or filter the water each time for use.

Separate Water Containers:

- 1) All water remaining in the container should be disposed of.
- 2) The exterior of the container should be thoroughly washed down removing any dirt and other contaminants.

- 3) Fill the container with an amount of water, swirl around and empty out.
- 4) Fully fill the container with water containing an appropriate sterilising solution and allow to stand for the recommended duration of time (see solutions explanatory information)
- 5) Empty the solution from the containers
- 6) The opening of the container should be thoroughly cleaned using a wipe impregnated with a sterilant.

Purchase suitable sterilising chemicals, available from your motorhome dealer, chemist or accessory shop.

The use of bleach or sodium metabisulphite for cleaning the water system is not recommended.

Waste Water System:

- 1) On your motorhome the waste water tank is stored underneath the chassis and is gravity fed.
- 2) If the waste water tank is overfilled it is possible the water will backfill the drain pipes until it eventually will appear in the Purchase suitable sterilising chemicals, available from your motorhome dealer, chemist or accessory shop.

The use of bleach or sodium metabisulphite for cleaning the water system is not recommended.

- 7) If possible store the water container inverted overnight.
- 8) The container should be filled with fresh water suitable for drinking and this only should be used for the above cleaning procedure.
- 9) On no account should garden hoses be used to fill the water tank.

For System:

- 1) Drain off the system (To drain quicker open all taps allowing air into the system).
- 2) Remove any water filters and replace with a short length of hose or empty filter cartridge (this will ensure the filter is not affected by the disinfectant/ sterilising solution)
- 3) Fill the water system with disinfectant/ sterilising solution (check the solution at full strength appears at the taps/shower). Allow to stand for the recommended period of time.
- 4) Completely drain off the water system.
- 5) Clean the outside of all taps/connectors with a cloth soaked in the disinfectant/ sterilant.
- 6) Use fresh drinking water to flush the system until there is no trace of the disinfectant/sterilant detected from any tap.



Waste Water System:

- 1) On your motorhome the waster water tank is stored underneath the chassis and is gravity fed.
- 2) If the waste water tank is overfilled it is possible the water will backfill the drain pipes until it eventually will appear in the shower base. (In order to prevent this please take note of part 3)
- 3) Displayed on the control panel the waste water gauge shows the level of the tank in quarter or half increments. We recommend that the waste water is checked on a daily basis emptying when required. To empty the waste water tank locate the valve on the off-side of the vehicle behind the door just beneath the side skirt. (see motorhome water tank locations)

The waste water tank should be emptied directly, or via a waste water container (not supplied) into a designated waste water area.

Pressure Switch:

The pressure switch is installed to monitor the pressure on the outlet side of the pump. When a tap is closed the pump will continue to run until the pressure in the system is increased to the pre-set level. When the pressure reaches a pre-set level is reached the pressure switch will turn the water pump off.

Pressure Switch Adjustment:

All of the Truma/Flo-Jet pumps used by us are pre-set at 28psi +/- 3psi. To further adjust the pre-set pressure switch pressure setting you will require to remove the cover cap located on the side of the pump to reveal a pressure adjusting screw (Fig 1). A + turn clockwise or anticlockwise is the maximum recommendation from the pre-set factory setting advised. Turning clockwise will increase and turning anti-clockwise will reduce water pressure.

Note:

- 1) The screw located below the cover cap is set in position and should not be disturbed.
- 2) The pump may have to be removed to gain access to the adjusting screw. Drain the water system before removing the pump.

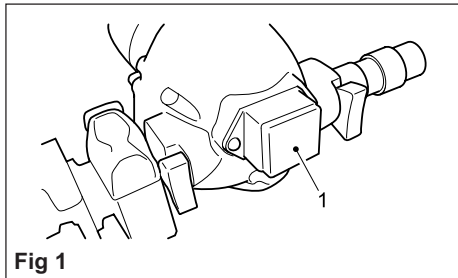

Fig 1

- 1 Remove Cover Cap

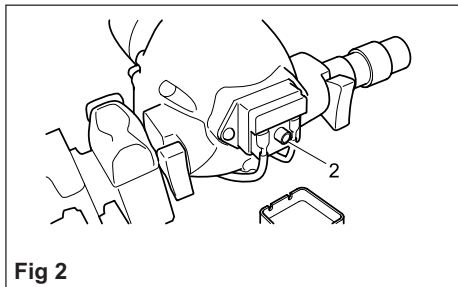

Fig 2

- 2 Pressure Switch Adjustable Screw



SERVICES

TROUBLESHOOTING:

In the event the pump fails to start when the taps are opened:

- 1) Check the fuse(s)
- 2) Check the power source(s), and ensure there is sufficient voltage to run through the pump.
- 3) Be sure to check the LED is illuminated on the pump.
- 4) Ensure there is power running to the pump using a multi-meter. If not refer to your dealer as there may be a fault with the fuse box or cable damage.
- 5) If the pump is hot to touch allow to cool before retrying.
- 6) Has the vehicle been winterised correctly? If not the pump may have frozen causing permanent damage.
- 7) An adjustment to the pressure switch may be required. (see pressure switch paragraph in this section for how to do this).

The pump is running but will not pressurise the water system (little or no water is being discharged from the tap):

- 1) Be sure to check there is water in the fresh water tank.
- 2) Check the in-line filler is free from debris and is correctly fitted.
- 3) Ensure that the water system has been primed correctly.
- 4) Check for restrictions in the water systems plumbing.
- 5) Ensure there is power running to the pump using a multi-meter. If not refer to your dealer as there may be a fault with the fuse box or cable damage.
- 6) Ensure the inlet side of the pump is water tight and not allowing air into the system.
- 7) Using a multi-meter check the voltage is between 10 and 14.5 volts. If not, refer to your dealer.



Pump continues to run (for more than 5 seconds) after taps are closed or pump turns on for no reason:

- 1) Check for leaks on the high pressure side of the pump.
- 2) Check the water system has been primed correctly.
- 3) Ensure the water pump is securely mounted.
- 4) Check that the piping on the high pressure side of the pump is in good condition.
- 5) An adjustment to the pressure switch may be required. (see pressure switch paragraph in this section for how to do this).

Noisy or rough operation:

- 1) Check for leaks on the high pressure and low pressure side of the pump.
- 2) Ensure that all pipes within 150mm of the pump are not touching any furniture.
- 3) Ensure the water pump is securely mounted.

Pump Rapidly Cycles or water pulses from the taps:

- 1) Check for leaks on the high pressure and low pressure side of the pump.
- 2) Check there are no restrictions in the plumbing.
- 3) An adjustment to the pressure switch may be required. (see pressure switch paragraph in this section for how to do this).



SERVICES

Fault	Cause	Solution
<p>No water running from taps when opened but the pump is running.</p>	<p>Fresh water tank is empty</p> <p>Pump wired in reverse</p> <p>Pipe in system has been disconnected</p> <p>Kinking in pipes</p> <p>A blockage in pump inlet or outlet pipe</p> <p>Pump filter blockage</p> <p>Air leak in suction line to the pump</p> <p>Frozen pipes</p>	<p>Check</p> <p>Check wiring, check manufacturers instructions</p> <p>Check pipe connections</p> <p>Inspect water system starting from the fresh water tank</p> <p>Clean filter, check manufacturers instructions</p> <p>Inspect pipes and pipe joints between the water tank and the pump</p>
<p>Water pump does not run</p>	<p>Pump incorrectly wired</p> <p>Pump fuse blown</p> <p>Battery disconnected</p> <p>Pump seized or overheated</p> <p>Pump pressure sensing switch may have failed</p> <p>Contacts may be faulty</p> <p>Wiring connections may be faulty</p>	<p>Refer to pump manufacturers instruction.</p> <p>Check the wiring connection and then replace with fuse and correct rating.</p> <p>Check connections</p> <p>Refer to pump manufacturers servicing instructions</p> <p>Refer to pump manufacturers servicing instructions</p> <p>Check contacts in plug and socket are clean and making contact</p> <p>Check wiring connections</p>

SERVICES



Fault	Cause	Solution
Water is flowing from the cold tap but not the hot	Blockage in the hot pipeline Kinked pipes preventing the water to flow Hot tap blocked or failed Heater non-return valve is jammed	Disconnect pipes and inspect Check and re-route if necessary Disconnect pipes and inspect Seek service attention
Water flows from hot tap but cold tap flow is reduced	Kinked pipe preventing flow Cold pipe line has blockage Cold tap is not connected Cold tap blocked or failed	Check and re-route if necessary Disconnect pipes and 1st connector and inspect up to tap Refer to installation instructions Disconnect and inspect
Reduced flow from hot and cold taps be reducing flow	Battery condition is low causing pump to run slowly If new taps have been fitted they may bore Pump needs servicing Partially blocked pump filter or in-line filter, if fitted Outlet pipe kinked restricting flow Water leak	Check state of battery charge Disconnect and check that they have at least 1/4" Refer to pump servicing instruction Dismantle and clean if necessary Check and re-route if required All water connections must be checked
Reduced flow from either tap	Pipe kinking restricting the flow Bore size different in taps	Inspect and re-route if necessary Use taps of an equal bore size
If pump motor runs steadily and will not stop	The battery voltage may be too low (below 10.5 volts)	Check that there is water in the container Adjust switch or re-charge the battery Check all the connectors in the pipe work



SERVICES

GAS

The gas locker is accessed by opening the vehicle exterior door.

The gas bottle compartment in your motorhome is designed to accommodate 2 x 6 kg gas bottles.

Gas Bottles

Bottled Liquidified Petroleum Gas (LPG) is the most convenient portable source of fuel for your Motorhome.

Make sure that heating, cooking appliances and gas cylinders are switched off before you move the Motorhome.

Regularly check flexible gas hoses, joints and connections for tightness. Finally make sure that each gas appliance is working efficiently to the recommendations of the appliance manufacturers.

In all cases the cylinder contents are in liquid form under pressure from the gas above it and the pressure is only dependent on the type of L.P.G. and its temperature.

When gas is supplied the pressure in the cylinder is slightly reduced and liquid 'boils' off to restore the balance. This action cools the liquid and the cylinder and condensation or even frost may sometimes be observed on the outside of the cylinder. The cylinder, when in use, is always cooler than the

surrounding air so allow plenty of circulation in cool weather and do not cover the cylinder with a "cozy" in the winter.

Butane works satisfactory at temperatures down to 2°C. Propane should be used for temperatures below this, therefore for all year round caravanners, Propane is of greater use.

Hoses connected from regulator to the motorhome supply should be made from Neoprene and comply with EN1949. Hoses have a limited life and should be inspected regularly.

The gas cylinders have location guides in the gas bottle compartment and should be restrained by means of the straps provided.

If cylinders are used outside this compartment you must ensure:

- 1) they are adequately supported
- 2) ventilation is not blocked and
- 3) damage will not be caused to fixtures and fittings.

Never use a gas cylinder on its side - always stand them upright and keep them in the gas locker provided.

If you should suspect a gas leak, turn off the gas at the bottle and ventilate the motorhome by opening the door and windows. Do not operate anything electrical and remove everyone from the motorhome until the gas has dispersed. It is part of your

annual service to inspect all gas pipes and appliances.

Changing a gas cylinder

Before commencing to change a gas cylinder ensure that the valve on the cylinder is fully turned off. Turn off all gas operated appliances.

Remove the gas hose from the gas cylinder.

Before refitting a gas cylinder, ensure that all gas operated appliances are turned off, particularly after winterisations. Ensure all connections are secure.



TYPES OF GAS

Butane

Butane is supplied in the U.K. in green, blue or aluminium bottles.

All these have a male left hand thread EXCEPT for Camping Gaz which has a special female right hand thread and Calor 7kg and 15kg and aluminium bottles which have a special clip-on connection.

Continental bottles usually have a male left hand thread similar to but not identical to U.K. butane.

Butane is suitable for use at temperatures down to 2°C but will not work below that.

Propane

Propane is supplied in Red, or partly red bottles which have a female left hand threaded connector.

Scandinavian countries use the same connector.

Germany and Austria supply propane with a male connection.

Propane will work at temperatures as low as -40°C and is therefore suitable for all winter use.

WARNINGS:

Never use gas bottles outside the Motorhome gas compartment. Do not use any gas extension hoses.

Ensure that the open end of the gas supply hose is protected against the entry of dirt or insects if it is to be left disconnected for any extended period.

If cylinders other than those recommended are used, ensure that the cylinders are adequately supported.

Never allow modification of LPG systems and appliances except by qualified persons.

General safety notes

If the gas system is leaking or if there is a smell of gas:

- extinguish all naked flames.
- do not smoke.
- switch off the appliances.
- shut off the gas cylinder.
- open the windows.
- do not actuate any electrical switches.
- have the entire system checked by an expert.
- if a leaking gas cylinder cannot be stopped, remove the cylinder to a safe place in the open air in an upright position away from drains and any source of ignition.



SERVICES

The Regulator

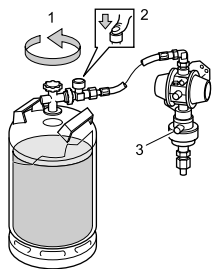

Gas Regulator

Your Motorhome is fitted with a MonoControl CS safety gas pressure regulation system. The gas pressure regulation system provides an even output pressure of 30 mbar or 50 mbar (depending on the variant) with a permissible admission pressure of 0.3 - 16 bar.

Hoses

A high pressure hose with hose rupture protection (HRP) is essential for connecting the gas cylinder to the gas pressure regulation system.

In the event of an accident with deceleration of $3.5 \text{ g} \pm 0.5 \text{ g}^*$ acting directly upon the triggering element, the integrated crash sensor interrupts the flow of gas.

The use of the gas pressure regulation is not permitted in confined spaces.

The pressure regulating devices and hoses must be replaced with new ones no more than 10 years after their date of manufacture (every 8 years is used commercially). This is the responsibility of the operator.

Heating while driving

With motorhomes as of construction year 01/2007, in accordance with the heating equipment directive 2001/56/EC with annexes 2004/78/EC and 2006/119/EC for the operation of a liquid gas heater while driving, a safety shut-off device must be provided that prevents gas from inadvertently escaping if a line breaks in the event of an accident.

In combination with a high-pressure gas hose with integrated hose rupture protection (HRP), the Truma MonoControl CS gas pressure regulation system with integrated crash sensor complies with all of the relevant standards, regulations and directives and therefore allows the gas system to be used throughout Europe, also while driving.

Operating Instructions

Open gas remote switch if present.

1. Open cylinder valve.
2. Firmly press the hose rupture protection (green button) on the high pressure hose.
3. If necessary (e.g. after a new installation or inadvertently striking the gas cylinder against the gas pressure regulation system), press the green reset button (crash sensor triggering element reset) on the MonoControl CS.

Changing the LPG Cylinder

Please use the included screwing tool to attach and remove the high pressure hoses. It will help you generate the necessary tightening torque and will prevent damage to the screw fittings, which may otherwise result from using an improper tool.

CAUTION: Residual gas: Do not smoke, avoid open flames!

- Close the empty gas cylinder's valve.
- Remove the high pressure hose from the gas cylinder or remove the slip-on adaptor, if present.
- Attach the high pressure hose to the full gas cylinder or fit the slip-on adaptor, if present.
- Open the full cylinder's valve.
- Press the hose rupture protection.

Note: Always check hose connection to the cylinder valve for leaks after making any changes.



GAS SAFETY ADVICE

Facts about LPG

LPG is not poisonous.

Bi-products are harmless.

There is danger if all air and oxygen were excluded.

(Ventilation holes must be kept clear at all times).

LPG has been given a smell by the manufacturers in order to identify leaks.

Only use gas cylinders stored in the dedicated gas locker. Do not attempt to fit extension hoses or use externally located gas bottles.

PRECAUTIONS

- a) Never look for a leak with a match. Always use a soap solution or its equivalent when testing connections. Do not operate any electrical apparatus whatsoever, especially light switches. If the leak is not obvious, the vehicle should be evacuated and qualified personnel consulted.
- b) Avoid naked lights when connecting or changing a cylinder.
- c) Inspect flexible gas hoses regularly for deterioration and renew as necessary with the approved type, in any case not later than the expiration date marked on the hose(s).

- d) The gas is heavier than air and therefore sinks to the lowest point.
- e) Keep bottle gas containers outside (and protected against frost). If they must be kept inside make sure they are well away from heat.
- f) Always read and follow the user and maintenance instructions provided by the manufacturers equipment. Should any soot accumulate on pans, fire radiants, etc. or any smell be produced, consult a competent installer on the correct maintenance and adjustment of burners.
- g) Where practical, turn off all appliances before retiring to bed, preferably at the cylinder or inlet to the caravan or other dwelling.

VENTILATION

General

Fixed ventilation is a statutory requirement in all Motorhomes. These ventilation apertures are positioned at both high and low level and for your safety should not be obstructed, even partially.

Low Level Ventilation

Under each appliance is a fixed ventilation aperture, of a size commensurate with the rating of the appliance itself. It is either gauze covered or incorporates a fixed plastic vent. This should be checked regularly to see that it has not become blocked.

High Level Ventilation

High level ventilation is provided by the roof vents. The ventilation provided has been carefully calculated and relates to the rating of the appliances in the vehicle. Roof vents must not be covered with anything that may limit or affect the ventilation they provide.

Maintenance

Under no circumstances should any fixed ventilation aperture be blocked, covered, either partially or fully, or be modified in any manner whatsoever. They should be checked at least annually for damage or blockage. Screens and/or grilles should be kept clean and free from dust.



SERVICES

All ventilation complies with BS EN 721 and vents should not be obstructed in any manner as this could lead to insufficient fresh air. In this case the confined atmosphere becomes depleted of oxygen which leads to the formation of the highly poisonous gas 'carbon monoxide'. Carbon Monoxide is odourless, colourless and tasteless and will rapidly cause unconsciousness and death with little or no warning prior to collapse.

THERE IS NO DANGER WHEN ADEQUATE VENTILATION IS PROVIDED.

When you are cooking, it is essential to provide additional ventilation such as opening windows near grill, cooker or oven.

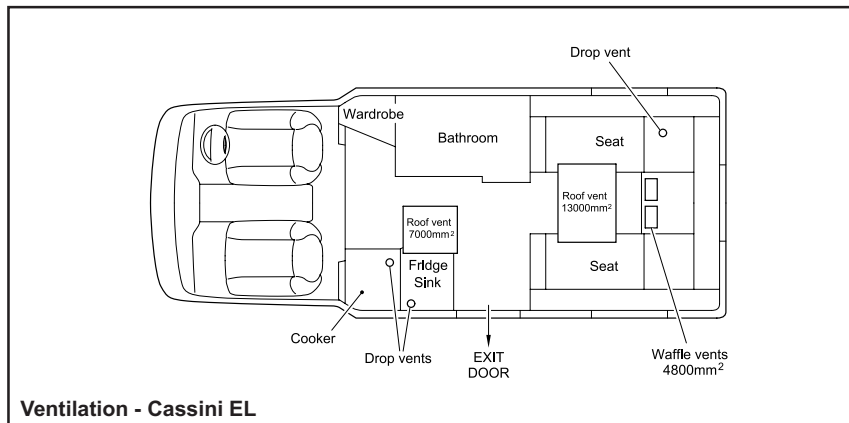
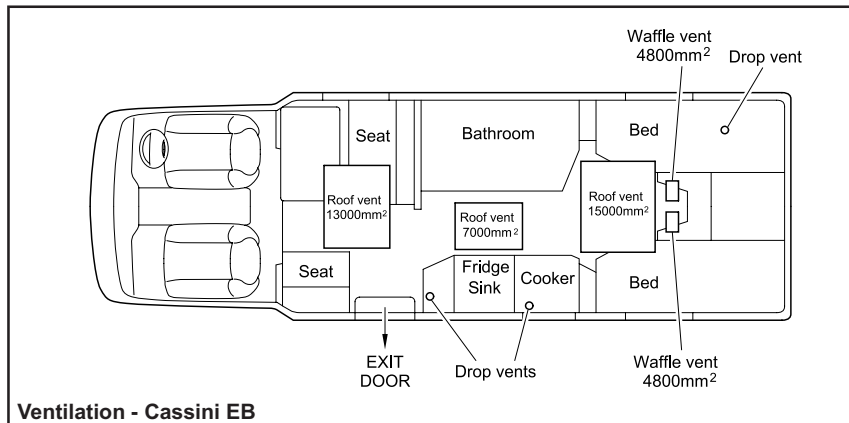

SERVICES

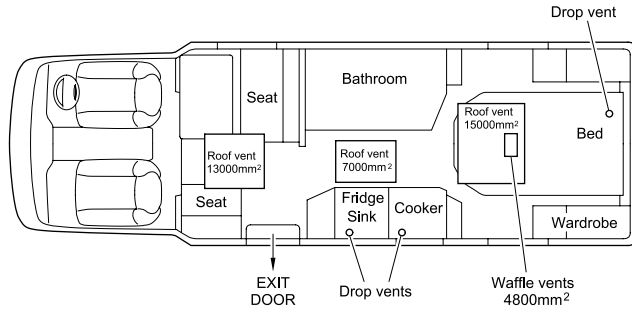

Ventilation - Cassini TI

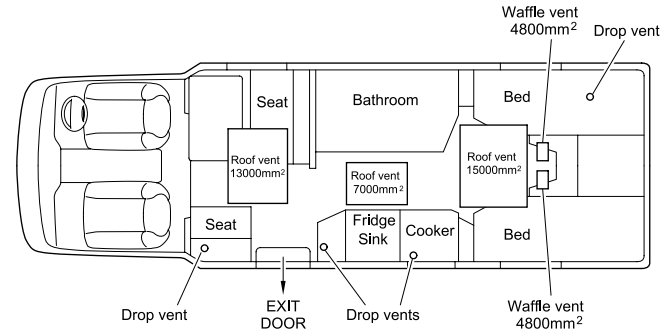

Ventilation - Roadstar EB

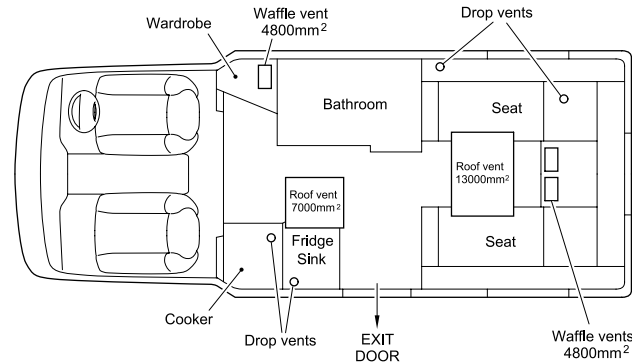

Ventilation - Roadstar EL

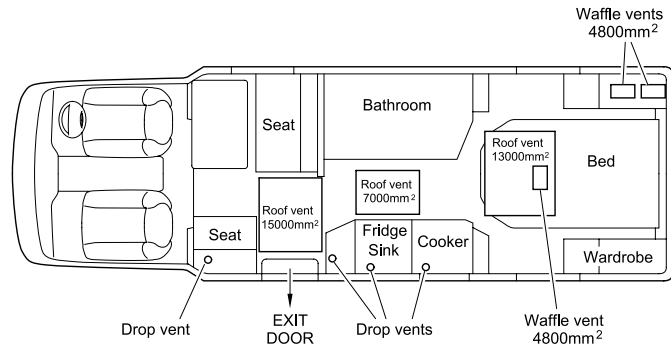

Ventilation - Roadstar TI



SERVICES

Gas System Isolation

Before turning on the gas supply, ensure that all gas operated equipment in the motorhome is turned off.

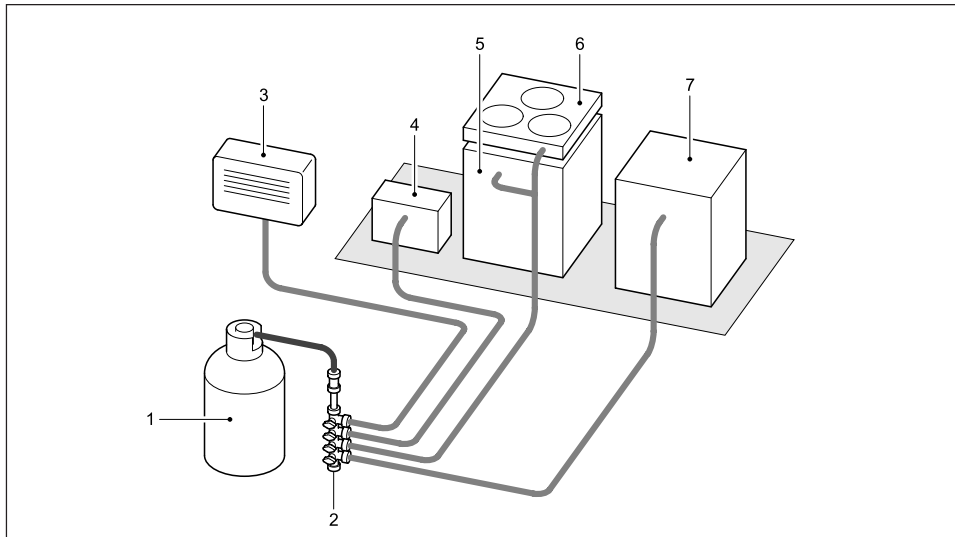

- 1 Gas storage tank
- 2 Isolating taps
- 3 Space heater (if fitted)
- 4 Water heater (if fitted)
- 5 Oven (if fitted)
- 6 Hob unit
- 7 Refrigerator

Safe Usage

To avoid accidents, the following fundamental advice should be carefully read before using gas appliances or changing gas cylinders.

- Always read and follow the use and maintenance instructions provided by the manufacturers of gas equipment. Should any soot accumulate on pans, fire radiants, etc., or any smell be produced, consult a competent installer on the correct maintenance and adjustment of burners.
- Never check for gas leaks with a naked flame.
- Always turn off the gas cylinder valve(s) or inlet to the motorhome or other dwelling when gas appliances are not in use.
- Never use gas appliances without adequate ventilation. All gas appliances require a plentiful supply of fresh air for correct operation. Fixed ventilators or air inlets should not be stopped up. Where practicable, turn off all appliances before retiring to bed, preferably at the cylinder or inlet to the motorhome or other •
Unless the appliance incorporates automatic ignition, when lighting an appliance always make sure you apply a lighted match or taper to the burner before turning on the gas.
- If any appliance is disconnected for repair, maintenance, etc., ensure that the gas line is capped off.
- If taps are stiff to operate or appear to be a source of leakage, call in a competent installer to rectify. LPG taps require a special grease.
- Always seek advice when in doubt.



INSTRUCTIONS FOR ELECTRICITY SUPPLY

On arrival at caravan site

General Information:

It is strongly advised that the mains installation is inspected periodically to ensure safe use. Wiring regulation BS7671 recommend that mains installations in motorhomes are re-inspected every 3 years or annually if the van is used frequently. The National Caravan Council list the required qualifications to perform this inspection.

On arrival at the camp site:

- 1) Check the suitability of the supply, if it is AC or DC and if the voltage and frequency are correct.
- 2) Ensure that there is a proper earth (3 pin socket outlet)
- 3) If in doubt always consult camp sight staff for guidance.
- 4) Make sure that the supply from the sight is switched off.
- 5) Make sure that the charger switch located on the PSU is switched off.
- 6) On the motorhome lift the cover of the electricity inlet located at the rear off side of the vehicle (Fig 1).
- 7) Insert the connector on the flexible supply cable (Fig 2).
- 8) At the site supply point insert the other end using the socket provided.
- 9) Switch on the mains switch at the site supply point.

Note: It is recommended to test the RCD (Residual Current Devices) in the PSU before switching on. There is a test button on the RCD to test the lever. Put the lever in the up position (on) before testing.

Note: As with the RCD it is good practice to check with the Miniature Circuit Breaker (MCB) in the PSU. Switch all to the on position (lever up). If any do not stay up then there is a fault.

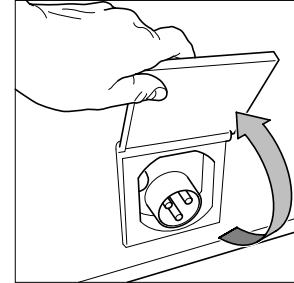

Fig 1

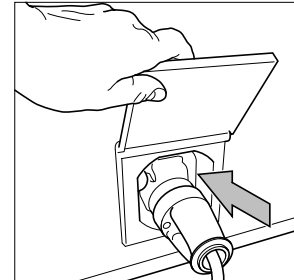

Fig 2



SERVICES

WARNING: The total 230v load in the Motorhome should not exceed 16A or in some case where the site protection is lower i.e. 6 or 10A otherwise nuisance tripping may occur or overloading of the inlet connector.

It is dangerous to attempt modifications and additions yourself. Never allow modification of electrical systems and appliances except by qualified persons. Lampholder-plugs (bayonet-cap adaptors) should not in any circumstances be used.

CAUTION: The space heater may be rated at 2Kw on 230v which will draw around 8A. This should be taken into consideration if you are on a site where the site supply protection is 6A or 10A. It is, therefore, advisable to check the supply rating before switching on two loads (items) greater than the supply as this may cause an overload and the circuit breaker to trip.

OVERSEAS CONNECTION

Note: Connection to a mains voltage supply OVERSEAS requires particular attention.

Care must be taken when connecting supplies abroad since the supplies can be of REVERSE POLARITY.

The significance of REVERSE POLARITY is that when equipment is switched off it may not be electrically isolated leaving a pole LIVE.

The only certain way of making equipment safe is to unplug it.

If it can be achieved, it is preferable to connect live to live, and neutral to neutral to maintain full electrical protection.



WARNING: It is essential that connections are made exactly as shown. If terminal markings are not in accordance with the diagram they must be ignored. If in doubt consult a qualified electrician.

The legal length of the mains inlet cable is 25 ± 2 metres. When in use it must be fully uncoiled and protected from traffic.

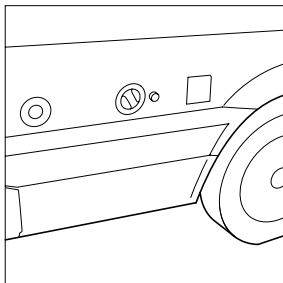
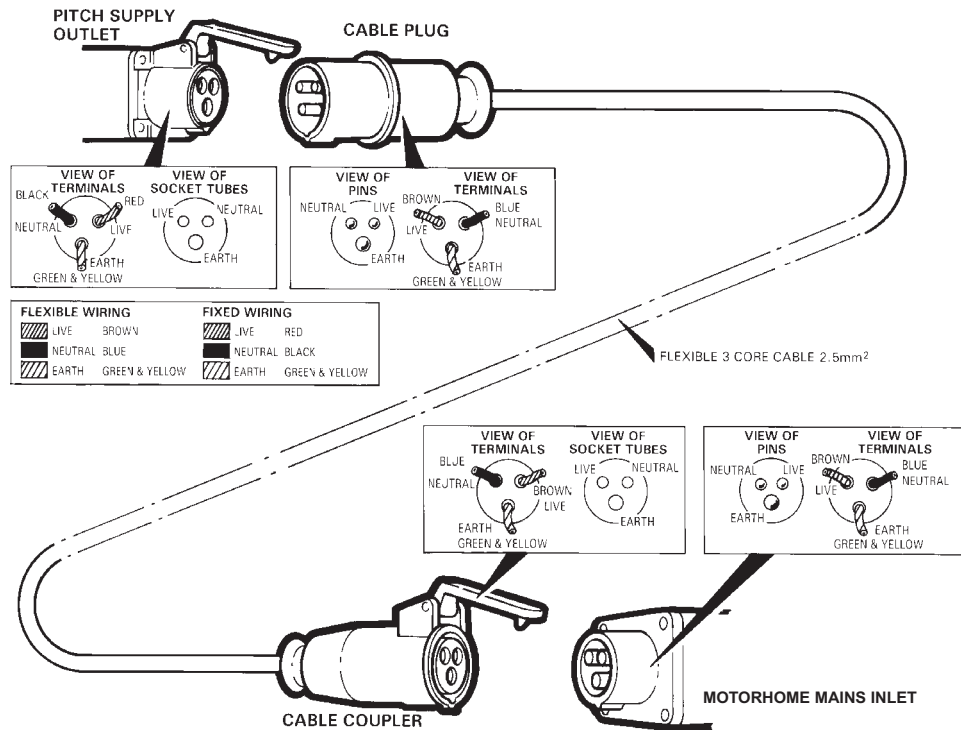

Wiring of connecting cable and Motorhome mains inlet



SERVICES

EC500 POWER CONTROL SYSTEM

1 INTRODUCTION

This section of the handbook will guide you through the operation of the electrical system.

Further technical details are contained in sections 3 to 6 or in the supporting technical manual available from www.sargentltd.co.uk

For the safe operation of all electrical equipment within your Leisure Vehicle it is important that you read and fully understand these instructions. If you are unsure of any point please contact your dealer / distributor for advice before use.

The system has a number of key components that you will need to be familiar with before attempting to use the system, these are:

- The EC500 series Power Supply Unit (PSU) - a combined mains consumer unit and 12V controller located in the front locker. On some vehicle layouts this unit may be located elsewhere.
- The EC300 or EC480 series Control Panel (CP) - a remotely located user control panel used to turn circuits on and off and to display battery and water tank information.
- The PX-300 Battery Charger / Power Supply - A separate, air cooled 300 Watt multi-stage power converter unit that charges the batteries and provides 12V DC power.

- The EM40 Interface Unit - This small unit is located at floor level behind the drivers' seat. The unit houses fuses for the fridge, vehicle battery, radio and other systems. It also provides connections for the optional tow bar harness.

2 USING THE SYSTEM

2.1 EC500 Power Supply Unit - Component Layout

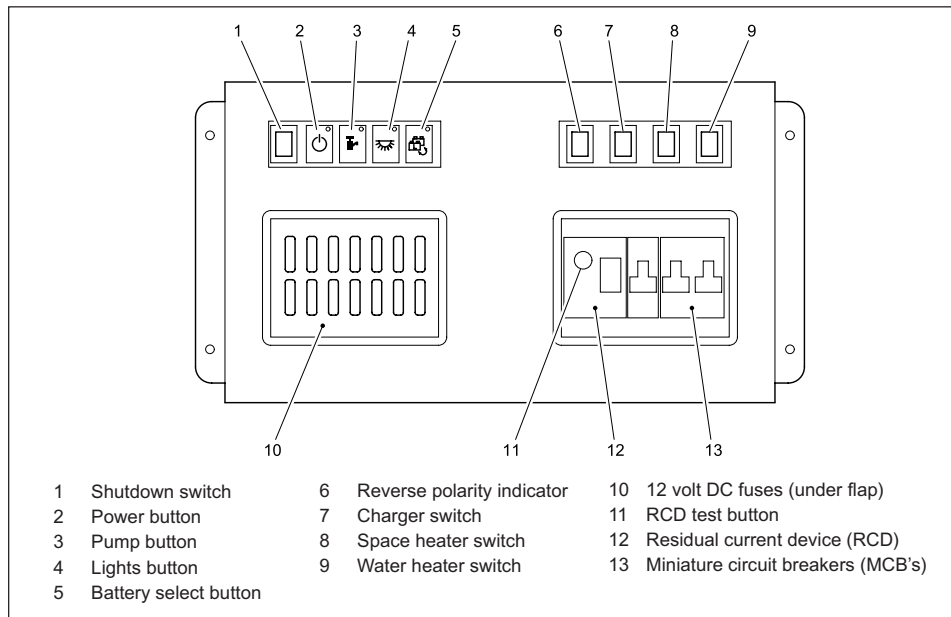



2.2 Activating the System

The EC500 system has a shutdown feature that should be used when the vehicle is in storage or is not being used for long periods of time. This allows the leisure electronics to be turned off when not required to save battery power. When in the off state the alarm and tracking system supplies are still active, most other supplies are turned off.

Before using the system please ensure the system shutdown switch is in the on position (button in).

PSU - 12V Controls

The black system shutdown button is shown on the left. In is on and out is off.

See section 2.5 for a description of the four control buttons.

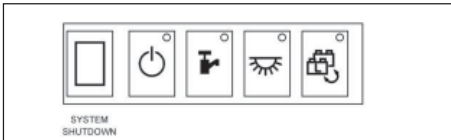

2.3 Connecting to the Mains 230V supply and Safety checks

For your safety it is IMPORTANT that you follow these connections instructions each time your Leisure Vehicle is connected to a mains supply. This section assumes that the system is complete and that a Leisure battery has been installed (see 3.5).

- A) Ensure suitability of the Mains Supply. Your Leisure Vehicle should only be connected to an approved supply that meets the requirements of BS7671 or relevant harmonised standards. In most cases the site warden will hold information regarding suitability of supply. If using a generator you also need to comply with the requirements / instructions supplied with the generator. Please note that some electronic generators may not be compatible with your leisure system. Further generator operational information is contained elsewhere in this manual.
- B) Switch the PSU internal Power Converter OFF. Locate the green 'Charger' power switch on the PSU and ensure the switch is in the off position (button out) before connection to the mains supply.
- C) Connect the Hook-up Lead. Firstly connect the supplied hook-up lead (orange cable with blue connectors) to the Leisure Vehicle and then connect to the mains supply.
- D) Check Residual Current Device operation. Locate the RCD within the PSU and ensure the RCD is switched on (lever in up position). Press the 'Test' button and confirm that the RCD turns off (lever in down position). Switch the RCD back to the on position (lever in up position). If the test button failed to operate the RCD see section 3.14.
- E) Check Miniature Circuit Breakers. Locate the MCB's within the PSU (adjacent to the RCD) and ensure they are all in the on (up) position. If any MCB's fail to 'latch' in the on position see section 3.14.
- F) Turn the PSU ON. Locate the black 'Shutdown' button and ensure it is in the on position (press button to change, button in = on, button out = off). Locate the green 'Charger' switch on the PSU and turn to the on position (press button to change, button in = on, button out = off). The charger switch will illuminate when turned on.
- G) Check correct Polarity. Locate the 'Reverse polarity' indicator on the PSU and ensure that the indicator is NOT illuminated. If the indicator is illuminated see section 3.10. Please note that this indicator works in conjunction with the charger switch, so will only operate when the charger is on.
- H) Check operation of equipment. It is now safe to operate the 12v and 230v equipment.

Note: When the vehicle is not in use the electrical system needs to be shut down via the 'System Shutdown' button located on the EC500 unit.

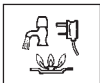

SERVICES

PSU - 230V Controls

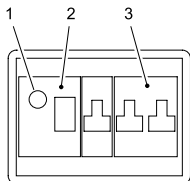

- 1 RCD Test Button
- 2 Residual Current Device (RCD)
- 3 Miniature Circuit Breakers (MCB's)

Black lever switch, far left - Residual Current Device (RCD) and main 230V on/off switch.

Yellow button, far left - RCD test button.

Red lever switches, right - 3 x 10A Miniature Circuit Breakers (MCB).

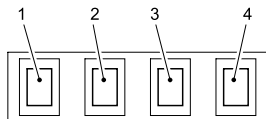

- 1 Reverse Polarity
- 2 Charger
- 3 Space Heater
- 4 Water Heater

Red indicator - Reverse polarity warning indicator. This illuminates when the green charger is turned on (see below) and the 230V supply polarity is reversed (see 3.14).

Green push switch - Charger switch, this switch turns the 12V battery charger on or off. In is on out is off.

Amber push switch - Space heater switch, this switch turns the 230V supply to the space heater / combination heater / central heating system on or off. In is on out is off.

Clear push switch - Water heater switch, this switch turns the 230V supply to the separate water heater on or off. In is on out is off.

Note: If the vehicle contains a combined space & Water heater then this button is not used.



2.4 EC480 Digital Control Panel (Colour graphic display)

Please refer to the following diagram to use your control panel.

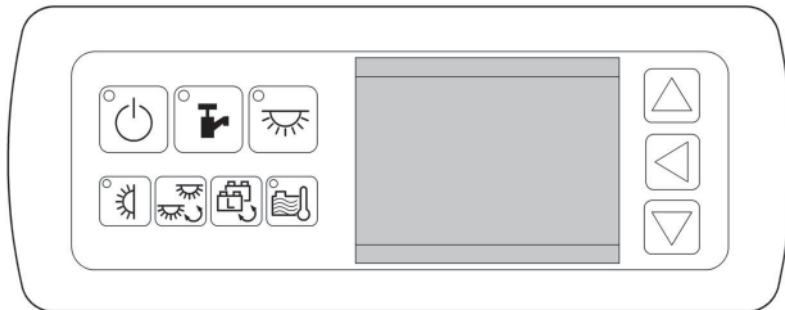



SERVICES

2.5 Control Panel Operation

EC480	Button Description
	Power Button. Press the power button to turn the leisure power on. Press the button again to turn the power off. The adjacent LED will illuminate when the power is on, and also the voltage of the selected battery will be displayed on the screen. This button is also present on the PSU unit, so this feature can also be operated from the PSU.
	Pump Button. With the power on, press the pump button to turn the water pump on. Press the button again to turn the pump off. The adjacent LED will illuminate when the pump is on, and also the level of the water tank will be displayed on the screen. This button is also present on the PSU unit, so this feature can also be operated from the PSU.
	Light Button. With the power on, press the light button to turn the main internal lighting on. Press the button again to turn the lights off. The adjacent LED will illuminate when the lights are on. The lights will be turned on and off automatically each time the power button is operated. This button is also present on the PSU unit, so this feature can also be operated from the PSU.
	Battery Select. By default, the leisure battery is selected as the power source if no mains supply is present, or as the battery to be charged when the mains supply is available. To change the selected battery, press the vehicle battery select button. The selected or 'Active' battery is shown on the screen, and on EC300 panels is also indicated by the adjacent LED (LED off = Leisure battery, LED on = vehicle battery).
	Awning Light Button. With the power on, press the awning light button to turn the awning light on or off. The adjacent LED will illuminate when the light is on.
	Frost Protect Button. When the frost protection option has been installed, with the power on, press the frost protect button to turn on the water tank heating system. The adjacent LED will illuminate to show that the tank heating system is on. To operate this feature from the EC300 control panel please see section 5.
	Light Dimming Button. With the power and lights on, press the dimming button to adjust the light level of the lights on the dimming circuit. On some vehicles this level can also be adjusted with the separate Infra Red (IR) remote control, or a separate wall mounted push button switch.
	Select. Use this button to select options/items or to cancel alarms/warnings. Note: The screen illumination/backlight will turn off after a period of time. Press the select button to reactive the illumination
	Scroll Down. Use this button to scroll through the various menu/screen items or to make setting adjustments.



2.6 Operation while driving

The EC500 system is designed to shutdown parts of the system whilst the engine is running. This is to meet Electro Magnetic Compatibility (EMC) regulations and to ensure the safe operation of your motorhome.

Please ensure the system shutdown switch on the PSU is in the “on” (button in) position before driving (see 2.2). This will ensure the electronic system is active and will therefore be able to control the charging process, supply the refrigerator and monitor other system circuits.

When fitted, designated 12v sockets, en-route reading lights and en-route heating will remain operational while the engine is running.

If you hear a warning buzzer when the engine is started, please see the control panel display for details and also refer to section 3.11.

3 System Technical Information

The following section provides further technical information relating to the electrical system.

3.1 System Configuration

There are a number of dealer configurable features within the system. Your dealer will discuss these options with you and make the

necessary adjustments as required. Should you wish to review the possible options / settings, further information can be sourced from www.sargentltd.co.uk

3.2 Residual Current Device & Miniature Circuit Breakers

The Residual Current Device (RCD) is basically provided to protect the user from lethal electric shock. The RCD will turn off (trip) if the current flowing in the live conductor does not fully return down the neutral conductor, i.e. some current is passing through a person down to earth or through a faulty appliance.

To ensure the RCD is working correctly, the test button should be operated each time the vehicle is connected to the mains supply (see section 2.3)

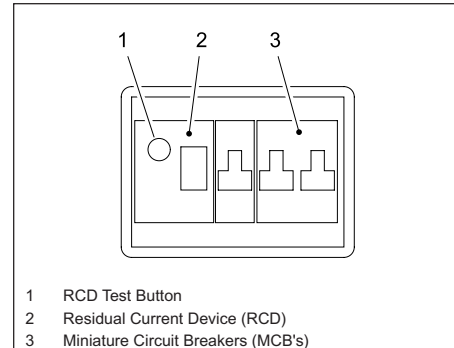

The Miniature Circuit Breakers (MCB's) operate in a similar way to traditional fuses and are provided to protect the wiring installation from overload or short circuit. If an overload occurs the MCB will switch off the supply. If this occurs you should investigate the cause of the fault before switching the MCB back on. The following table shows the rating and circuit allocation for the three MCB's



SERVICES

The following table shows the rating and circuit allocation for the three MCB's

MCB	Rating	Output Wire Colour	Description
1	10 Amps	White	230v Sockets
2	10 Amps	White (Yellow for heater)	Extra 230v Sockets / Space Heater
3	10 Amps	Black (Blue for water heater)	Fridge / Water Heater / 12v Charger (internally connected)

3.3 Battery Charger

The EC500 system incorporates an intelligent three-stage battery charger / power converter.

During stage 1 the battery voltage is increased gradually while the current is limited to start the charging process and protect the battery. At stage 2 the voltage rises to 14.4V to deliver the bulk charge to the battery. When the battery is charged, the voltage is decreased at stage 3 to 13.6V to deliver a float charge to maintain the battery in the fully charged state. The charger can be left switched on continuously as required.

The battery charger / power converter also provides power to the leisure equipment when the mains supply is connected. This module supplies DC to the leisure equipment up to a maximum of 25 Amps (300 Watts), therefore the available power is distributed between the leisure load and the battery, with the leisure load taking priority as per the following example:

Leisure load	Available power for battery charging
5A	20A
10A	15A
15A	10A
20A	5A

WARNING: Under heavy loads the charger case may become hot. ALWAYS ensure any ventilation slots have a clear flow of air. Do not place combustible materials against/ adjacent to the charger.

3.4 Smart Charging

The EC500 system incorporates a smart charge feature, which monitors both leisure and vehicle batteries and automatically adjusts and directs the charger power (and solar power if a solar panel is installed) to maintain the leisure and vehicle batteries at an optimal level.

3.5 Leisure Battery

3.5.1 Type / Selection

For optimum performance and safety it is essential that only a proprietary brand LEISURE battery is used with a typical capacity of 75 to 120 Ah (Ampere / hours). A normal vehicle battery is NOT suitable. This battery should always be connected when the system is in use.

The PSU is configured to work with standard lead acid leisure batteries, and in most cases is also compatible with the latest range of Absorbed Glass Matt (AGM) batteries. Before fitting non-standard batteries please check that the charging profile described in 3.3 is suitable for the type of battery by referring to the battery documentation or battery manufacturer.

Some vehicle installations can cater for two leisure batteries connected in parallel. In these cases it is recommended that two identical batteries are used.



The battery feed is fitted with an inline fuse between the battery and the electrical harness, and is usually located immediately outside the battery compartment or within 500mm of the battery. The maximum rating of this fuse is 20A per battery. If a single battery is fitted to a motorhome, this fuse may be increased to 30A, however if two batteries are fitted each battery should be fused at a maximum of 20A.

WARNING: Any replacement of an auxiliary battery shall be of the same type and specification as that originally fitted or as specified by the manufacturer.

3.5.2 Installation & Removal

Always disconnect the 230v mains supply and turn the PSU green charger switch to the off position (button out) before removing or installing the battery.

When connecting the battery, ensure that the correct polarity is observed (black is negative [-] and red is positive [+]) and that the terminals are securely fastened. Crocodile clips must not be used.

WARNING: Explosive gases may be present at the battery. Take care to prevent flames and sparks in the vicinity of the battery and do not smoke.

3.5.3 Operation / Servicing

Under normal circumstances it should not be necessary to remove the battery other than for routine inspection of the terminals and “topping up” of the battery fluid where applicable. Please see instructions supplied with the battery.

Note: Do not over discharge the battery. One of the most common causes of battery failure is when the battery is discharged below the recommended level of approximately 10v. Discharging a battery below this figure can cause permanent damage to one or more of the cells within the battery.

To prevent over discharge, the EC500 system incorporates a battery protect circuit that warns the users and then disconnects the batteries when they fall below set values.

If the power is turned on and the leisure battery level falls below 9V a warning beep will be heard and information will be shown on the screen. To cancel the warning, press the select button.

If the power is turned on and the vehicle battery level falls below 10.9V a warning beep will be heard and information will be shown on the screen. If no action is taken the system will switch over from the vehicle battery to the leisure battery. To cancel the warning, press the select button.

These warnings will not be repeated unless the power switch is turned off and on again. This is to ensure the warning does not become a nuisance.



SERVICES

Battery	Cut off	Action after cut off	Notes
Vehicle	10.9V	Battery selection is changed from Vehicle battery to Leisure battery. If the leisure battery is below 9V then a further warning will occur (see below).	This cut off level is designed to protect the vehicle battery from over discharge. The 10.9V level ensures there is sufficient power in the battery to run the vehicle electronics and start the vehicle. This cut off only applies to power drawn from the battery by the leisure equipment; it will not protect the battery if you leave vehicle circuits switched on, such as the road lights.
Leisure	9V	Power is turned off	This is an emergency cut off level to protect the battery from severe damage. You should not rely on this cut off level during normal operation, but manage your power consumption to a discharge level of 10V. This cut off only applies to power drawn from the battery by the leisure equipment that is controlled by the control panel power switch; it will not protect the battery from discharge by permanently connected equipment.

3.6 Solar Charge Management

The EC500 PSU incorporates a built-in solar charge management feature, which will control the input from a solar panel (when fitted, maximum rating 120W). Depending on the charge state of the batteries, the solar power will be directed to the required battery, and continuously monitored to ensure optimum operation. For this system to operate intelligently, the shutdown button should be left switched on. If the shutdown button is turned off then the solar panel will charge the leisure battery only.

8-28

3.7 Water System Operation

The control panel pump button operates the internal (onboard) water pump. This pump will draw water from the internal (onboard) water tank.

The water tanks (fresh & waste) incorporate a level warning feature to warn the user when the fresh water level drops below 25% or when the waste water level reaches 100%.

If the water pump power is turned on and the

fresh water level drops to below 25% a warning beep will be heard information will be shown on the screen. To cancel the warning, press the select button.

If the water pump power is turned on and the waste water level rises to full (100%) a warning beep will be heard and information will be shown on the screen. To cancel the warning, press the select button.

These warnings will not be repeated unless the water pump power switch is turned off and on again. This is to ensure the warning does not become a nuisance.

3.8 Frost Protection

On vehicles fitted with water tank frost protection, the EC480 control panel frost protect switch can be used to turn the feature on or off.

3.9 Awning Light Operation

The awning light is control by the control panel awning / aux button. The awning light is also linked to the remote door locking. If the doors are locked or unlocked the light will illuminate for a short period of time. This is a dealer configurable item.

3.10 Electric Step Operation

On vehicles fitted with an electric step, this is operated by a button near the entry door.



Press and release the button to move the step in or out. One press of the button will move the step out, a further press will move the step in again.

If the engine is started the step will move in automatically, after a short warning buzzer. If this operation fails due to an obstacle or mechanical failure a buzzer will sound continuously to warn that the step is still in the out position, and therefore requires your attention.

The electric step is also linked to the remote door locking. If the doors are unlocked the step will move out, if the doors are locked the step will move in. This is a dealer configurable item, and can be turned off if not required.

3.11 System Warnings

The system incorporates a number of warnings that are active at specific times. These are summarised below, and also covered by relevant sections of this manual.

Warning	When	Type
Fresh water level low	With pump turned on and fresh water level low (less than 25% full)	Message on screen and 1 minute audible beep
Waste water level full	With pump turned on and waste water level full (tank level 100%)	Message on screen and 1 minute audible beep
Vehicle battery voltage low	With control panel power on and vehicle battery selected (as active battery) and voltage level below 10.9V	Message on screen and 1 minute audible beep. If no action taken after 1 minute then the system will switch to the leisure battery
Leisure battery voltage low	With control panel power on and leisure battery selected (as active battery) and voltage level below 9V	Message on screen and 1 minute audible beep. If no action taken after 1 minute then the system will switch the power of to prevent over discharge of the battery
Alarm clock active	When alarm has been turned on and alarm time has been reached	Message on screen and 1 minute audible beep
Engine running	When the engine is started the system power will be turned off	Message on screen, on EC480 this will remain visible for 1 minute
Step still out	When the engine is started and the step has failed to retract automatically	Message on screen and rapid beeps from the control panel. The beeping will not stop until the fault is cleared.
Mains lead (hook-up cable) still connected / plugged in	When the engine is started and the mains cable is still plugged in and switched on	Message on screen and repeated beeps from the control panel. The beeping will not stop until the fault is cleared.



SERVICES

3.12 Event Timer Operation

The event timer is designed to allow the motorhome user to turn the 12v power on or off (in the same way as using the control panel power button) without being in the vehicle. This allows lights or other equipment to be turned on or off at a predetermined time.

Example - to turn on one interior light at 11.00pm for 1 hour

Ensure the clock is set to the correct time

EC480

Scroll to the System Time Setting screen

Follow the instructions in section 4 to set the ON time to 23:00 and the OFF time to 24:00

Set the Timer to ON

A stopwatch symbol will appear in the header area to indicate the timer is set

Turn all lights and 12v equipment off in the vehicle except the light that you want the event timer to automatically switch on

Exit the vehicle At 11:00pm (23:00) the control panel will switch the 12v power on and therefore any equipment that was left switched on will be turned on. The 12v power will be switched off at Midnight (24:00)



3.13 12 Volt DC Fuses

WARNING: When replacing fuses always replace a fuse with the correct value. NEVER replace with a higher value/rating as this could damage the wiring harness. If a replacement fuse 'blows' do not keep replacing the fuse as you could damage the wiring harness. Please investigate the fault and contact your dealer.

The following table shows the fuse allocation for the 15 fuses fitted to the PSU. Please note that fuses are dependant on PSU versions, so not all fuses may be present.

The table opposite shows the fuse allocation for the 15 fuses fitted to the PSU. Please note that fuses are dependant on PSU versions, so not all fuses may be present.

Fuse	Rating	Fuse Colour	Description
1	10 Amps	Red	Toilet
2	5 Amps	Tan	Ignitions
3	10 Amps	Red	Electric Step
4	10 Amps	Red	Water Pumps
5	10 Amps	Red	Permanent Supplies
6	20 Amps	Yellow	Leisure Battery
7	20 Amps	Yellow	Vehicle Battery
8	10 Amps	Red	Fans
9	10 Amps	Red	Power Circuits
10	10 Amps	Red	Lighting Circuit 1
11	10 Amps	Red	Lighting Circuit 2
12	10 Amps	Red	En-route Circuits
13	10 Amps	Red	Tank Heaters
14	10 Amps	Red	Future Supply
15	25 Amps	White	Charger (fitted internally to PSU)

The following table shows details of the fuse(s) located at the Leisure battery.

Fuse	Rating	Fuse Colour	Description
Battery 1	20 Amps	Yellow	Fuse remotely located near battery
Battery 2	20 Amps	Yellow	Fuse remotely located near battery 2 (where fitted)



SERVICES

The following table shows details of the fuse(s) located at the EM40 Interface Unit

Fuse	Rating	Fuse Colour	Description
1			Spare location
2	5 Amps	Tan	Marker Lights
3	20 Amps	Yellow	Tow Bar +
4	20 Amps	Yellow	Vehicle Battery
5			Spare location
6	20 Amps	Yellow	Fridge +
7	20 Amps	Yellow	Tow Bar D+
8	20 Amps	Yellow	Fridge D+

3.14 Common Fault Table

Fault	Possible Cause	Proposed Fix
No 230 volt output from PSU	Connecting lead between the site and Leisure Vehicle not connected	Check and connect lead as per 2.3C
	RCD switched off	Reset RCD as per 2.3D
	RCD not operating correctly	Check supply polarity; if the RCD continues to fail contact your Dealer as there is probably an equipment or wiring fault
	MCB switched off	Reset MCB by switching OFF (down position) then back ON (up position), if the MCB continues to fail contact your Dealer as there is probably an equipment or wiring fault
	No or deficient supply from site	Contact site Warden for assistance
Reverse Polarity light is illuminated on PSU	Mains Supply reversed?	The reverse polarity light is designed to illuminate when the Live and Neutral supply has been reversed/crossed over. If the light illuminates there is a problem with the site supply or the cable connecting the supply to your vehicle. The light is designed to work on UK electrical supplies (where the neutral conductor is connected to earth at the sub station). If you are using your vehicle outside the UK this light may illuminate when no fault exists. In these cases consult the site warden for advice.



3.14 Common Fault Table (continued)

Fault	Possible Cause	Proposed Fix
	Generator being used	'The Reverse Polarity warning light is on when using my Generator'. This is a normal side effect when using some types of generator. Instead of connecting the neutral conductor to earth, some generators centre tap the earth connection making both neutral and live conductors 110V above earth. This 110V difference causes the neon polarity indicator to illuminate. In most cases it is still safe to use the generator, but please consult the generator handbook for further information.
Control Panel problems	Control Panel has no display	Backlight/illumination may have switched off. Press the select button to reactivate the backlight. Check batteries and fuses, turn PSU shutdown switch and charger switch on and ensure mains supply is connected. Check control panel connecting lead at PSU and behind Control Panel. Contact your Dealer
	12V power turns off	Battery protect feature has operated to protect the Vehicle battery and or the Leisure battery. See 3.5.3. Engine has been started, all equipment has been disconnected to meet EMC requirements. See 2.7.
	Control Panel locked/erratic function	Observe control panel handling instructions. Control panel software may have crashed. Reboot control panel by turning off the PSU isolate switch. Wait 30 seconds then turn the switch back on.
No 12 volt output from PSU	No 230V supply	Check all above
	Charger not switched on	Turn charger switch on, switch will illuminate
	Battery not connected and/or charged	Install charged battery as per 3.5
	Power button on control panel not switched to on	Turn power on at control panel
	Battery flat / Battery fuse blown	Recharge battery, check fuses, check charging voltage is present at battery
	Fuse blown	Check all fuses are intact and the correct value fuse is installed as per fuse table
	Equipment switched off / unplugged	Check equipment is switched on and connected to the 12V supply
	PSU overheated / auto shutdown operated	Reduce load on system. Allow PSU to cool down. PSU will automatically restart when cool.
	Other fault	Contact your Dealer
Pump not working	Fuse blown	Replace fuse with correct value as per fuse table
	Pump turned off	Turn pump on by pressing the pump button at the control panel
	Setting incorrect	Both the internal and external pump feeds are controlled from the control panel. To alter the setting of the pump switch see your dealer. Ensure the setting matches your desired requirement.



SERVICES

3.15 Contact details

Sargent Electrical Services Limited, provide a technical help line during office hours. Please contact 01482 678981 if you require technical help. For out of hour support please refer to the tech support section of the Sargent web site www.sargentltd.co.uk.

4 EC480 Control Panel

In addition to the information contained in section 2.5 (Control Panel Operation), the following section provides further detail information.

4.1 Backlight Operation

The screen backlight (illumination) is turned on and off automatically. When operating on battery power only the backlight time is 30 seconds. When operating on mains power the backlight time is increased to 2 minutes. Pressing the select button will reactivate the backlight.

If the large clock screen is selected (see 4.4.4 below) and the mains supply is on then the backlight will remain on continuously.

4.2 Header Area



The header area of the screen shows the following information;
At the left, the external temperature in centigrade

At the right, the internal temperature in centigrade
In the centre, the current time (24 hour clock)
In addition to the above, the following symbols (when shown) indicate;



Mains supply connected and charger

switched on



Alarm clock set



Event timer set

4.3 Footer Area



The footer area of the screen shows details of the current information screen, and may also show additional information during specific operations.

4.4 Information Area

The main information area can display a variety of system information screens. These have been designed to present the information in a clear and concise form, while retaining technical detail for the more advanced users.

The selected screen can be changed by using the down or up buttons, and work on a continuous loop basis. The selected screen may be changed automatically by the system depending on the action being performed.

4.4.1 Splash Screen

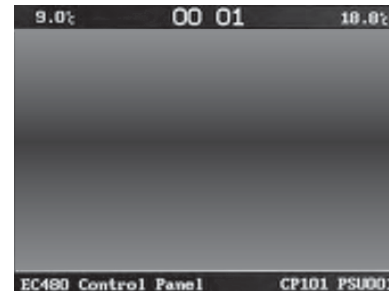

This screen shows the header and footer detail, along with the logo.

4.4.2 System Levels Screen

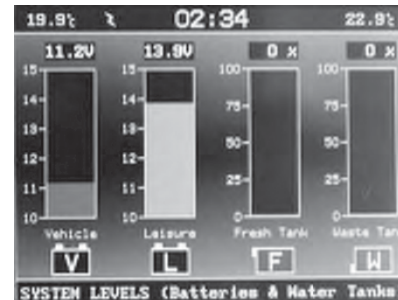

This screen shows, from left to right;



- [V] Vehicle battery voltage gauge. This gauge shows the voltage of the Vehicle battery in bar format, with the precise reading shown at the top of the bar. The actual bar changes colour according to the battery voltage. Less than 10.9V = red (Poor), 10.9V to 11.8V = yellow (Fair), 11.9V to 14.4V = green (Good).
- [L] Leisure battery voltage gauge. This gauge shows the voltage of the Leisure battery in bar format, with the precise reading shown at the top of the bar. The actual bar changes colour according to the battery voltage. Less than 10.9V = red (Poor), 10.9V to 11.8V = yellow (Fair), 11.9V to 14.4V = green (Good).
- [F] Fresh water level gauge. This gauge shows the level of water in the Fresh water tank, with the reading also shown at the top of the bar. The actual bar changes colour according to the water level. 25% = red, 50% = yellow, 75% and above = green.
- [W] Waste water level gauge. This gauge shows the level of water in the Waste water tank, with the reading also shown at the top of the bar. The actual bar changes colour according to the water level. 25% = green, 50% = yellow, 75% and above = red.

4.4.3 Active Battery Screen

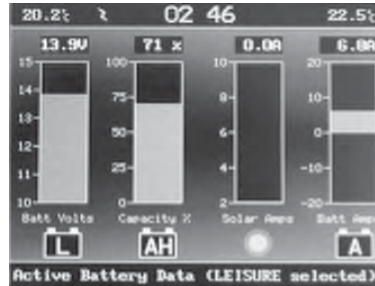

This screen is automatically selected when the battery select button is operated. The battery symbol bottom left will contain a 'L' if the leisure battery is selected and a 'V' if the vehicle battery is selected. From left to right;

- [L or V] Active battery voltage gauge. This gauge shows the voltage of the Active battery (the currently selected battery) in bar format, with the precise reading shown at the top of the bar. The actual bar changes colour according to the battery voltage. Less than 10.9V = red (Poor), 10.9V to 11.8V = yellow (Fair), 11.9V to 14.4V = green (Good).
- [AH] Leisure battery calculated capacity (percentage of Amp Hours). When the leisure battery is active (selected), this gauge will be shown. The gauge shows the predicted charge capacity of the battery. As

the battery is charged this gauge will increase, as the battery is discharged (used) this gauge will reduce. This can provide a useful indication of usable battery power.

- [SUN] Solar panel ammeter. This gauge shows the current in Amps that is being provided by the solar panel (when fitted). The system will decide which battery to direct the solar power to. This is based on system logic (see section 3.6) and is indicated by a 'L' or 'V' in the centre of the sun logo.
- [A] Battery ammeter. This gauge shows the current in Amps going into or out of the Active (selected) battery. Positive current (+) indicates charging of the battery, and is indicated by a green bar. Negative current (-) indicated discharging of the battery, and is indicated by a yellow bar (low discharge) or red bar (high discharge).



SERVICES

4.4.4 Large Clock Screen



This screen shows a large display clock in 24 hour format.

4.4.5 Time and Timer Event Settings Screen

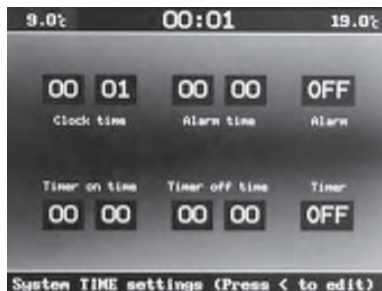

This screen is used to adjust any of the system times and to set the alarm clock or event timer.

Press the select button to move through each setting. Press the up / down buttons to adjust the setting.

- Set Clock Time. First adjust the hour using the up / down buttons, then press select again to move to minutes and adjust with the up / down buttons.
- Set Alarm Time. Press the select button to move to alarm hour setting. Press the up / down buttons to adjust the setting, then press select again to move to minutes and adjust with the up / down buttons. Press select again to move to alarm on / off. Press the up / down buttons to adjust the setting. If the alarm is turned on, a bell symbol will be shown in the header area.
- Set Timer event on Time. Press the select button to move to timer hour setting. Press the up / down buttons to adjust the setting, then press select again to move to minutes and adjust with the up / down buttons.
- Set Timer event off Time. Press the select button to move to timer hour setting. Press the up / down buttons to adjust the setting, then press select again to move to minutes and adjust with the up / down buttons. Press select again to move to timer on / off. Press the up / down buttons to adjust the setting. If the timer is turned on, a stopwatch symbol will be shown in the header area.
- Press select again to exit the settings

4.4.6 System Warnings Screens



The system can display a number of warnings. The control panel will beep and display the appropriate message. Press the select button to cancel the warning.



5 TECHNICAL DATA & APPROVALS

5.1 Outline specification - EC500PSU & EC300, EC480 Control Panel

INPUT 230V	230 Volts / 0 to 16 Amps	+ / - 10%
OUTPUT 230V	RCD protected, 3 x MCB outputs fo 10A Separate switched channels for water heater, space heater and charger	
INPUT 12V	2 x 20A battery inputs via 2 x 4 way connectors	
SOLAR INPUT	1 x Dedicated solar panel input (20 to 100W panel) via a 4 way connector	
OUTPUT 12V	25A total output via multiple switched channels protected by 14 fused outputs	
CHARGER	Input 220-240 Volts AC +/- 10%, Frequency 50 Hz +/- 6%, Current 3A max. DC Output 13.6 to 14.4 Volts nominal, Current 25 Amps max (300 Watts) Overall size (HxWxD) 50 x 250 x 135mm	Fixing centres 128*128mm 1.2kg
Signal INPUT	4 x Fresh water level, 4 x Waste water level, 1 x Engine running, plus multiple vehicle connections	Fresh water negative sensed Waste water negative sensed
Data IN / OUT	CANBUS Data communication and power to Control Panel via 6 way connector	
IP rating	IP31	
Operating temperature	Ambient 0 to 35° Centigrade PSU case temperature with full load 65°C Max	Automatic shutdown and restart if overheated/overloaded
EC500PSU	Overall size (HxWxD) 315 x 195 x 150mm Clearances 75mm above, 50mm left and right	Weight 2.9kg
EC300, EC480 Control Panel	Overall size (HxWxD) 80 x 194 x 25mm Cut-out size (HxW) 60 x 165mm	Fixing centres 178mm Weight 140g



WIRING DIAGRAMS

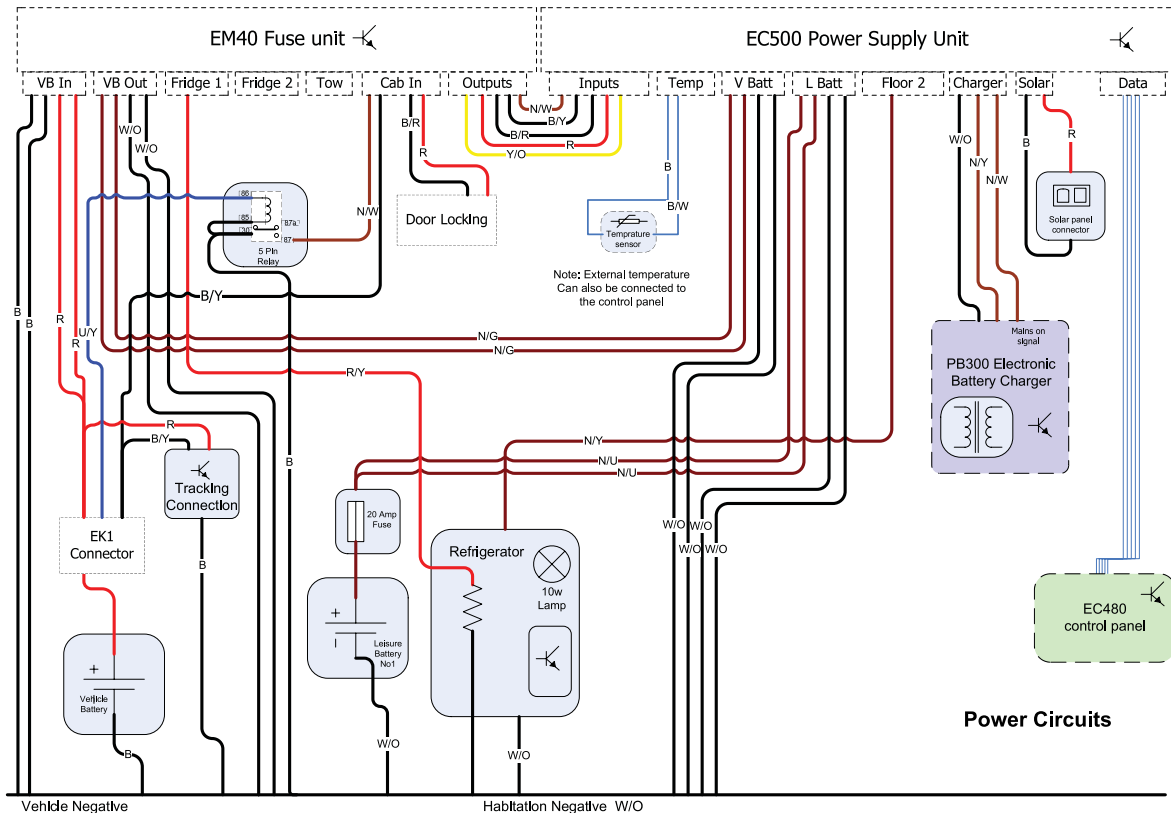



WIRING DIAGRAMS

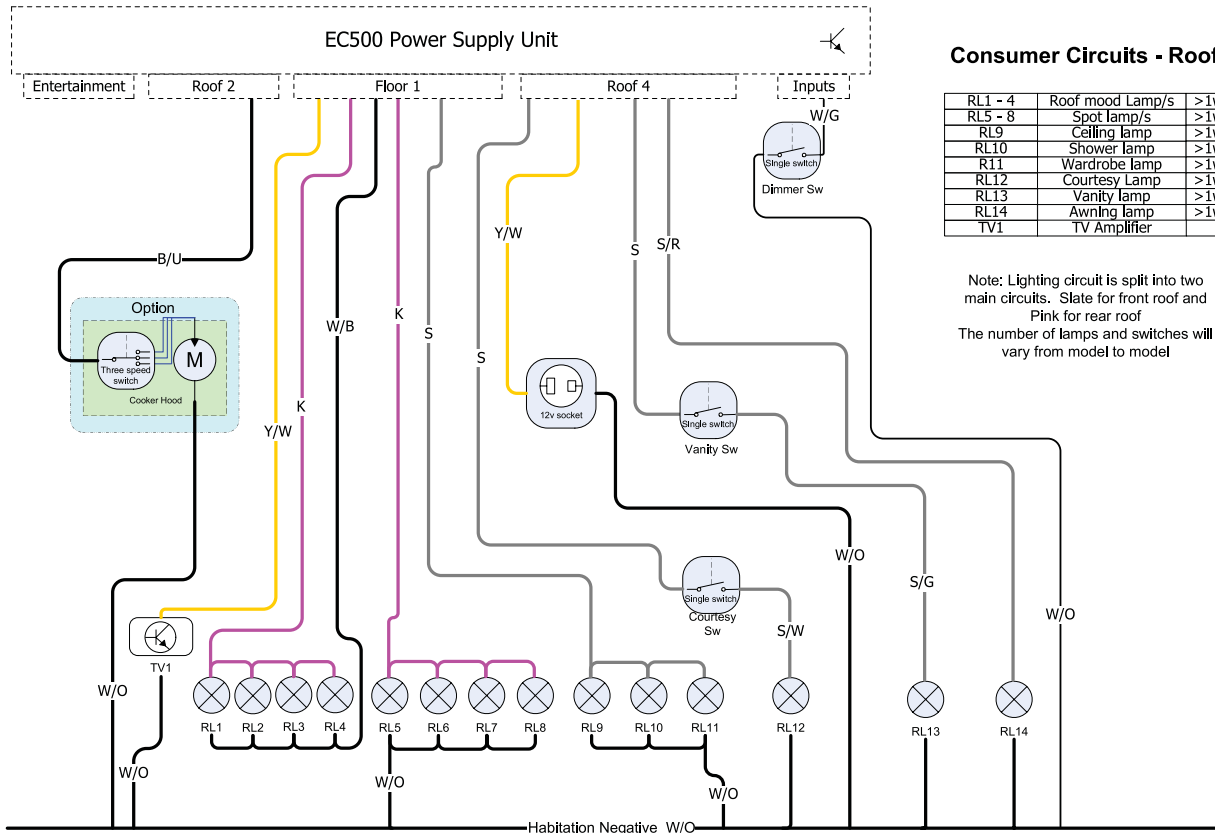



CABLE COLOUR CHARTS



Y/U

Example

Yellow cable with Blue stripe

Cable Colour Chart

12v Cable Colours

B	BLACK
N	BROWN
R	RED
O	ORANGE
Y	YELLOW
G	GREEN
U	BLUE
P	PURPLE
S	SLATE GREY
W	WHITE
K	PINK

230v Cable Colours

B	BLACK
N	BROWN
W	WHITE
O	ORANGE
Y	YELLOW
G	GREEN
U	BLUE



Note: Most proprietary items within the Motorhome will have their own instruction book. The information within the Handbook is an extract of the most relevant aspects.

IMPORTANT

In the interest of safety, replacement parts for an appliance shall conform to the appliance manufacturer's specifications and should be fitted by them or an authorised agent.

To maximise the use and life of all fitted equipment in your Motorhome it is essential that any accompanying manufacturer literature is read fully. All recommended maintenance and preparation procedures should be followed. The information provided in this handbook is only intended as a guide. If in any doubt consult your motorhome appointed dealer, particularly before attempting to install extra equipment.



EQUIPMENT DETAILS

TRUMA COMBI BOILER (EL Models)

Introduction

The liquefied gas heater 'Truma Combi' is a warm air heater with an integrated hot water boiler (10 litre volume) the burner operates fan supported, which ensures trouble-free function even when on the move.

The heater can be used to heat the room, heat the room and water at the same time or just heat hot water.

In warmer conditions the water contents are heated using the small burner. Once the water temperature is reached, the burner switches off.

In winter or in lower temperatures the unit will automatically select the required power setting according to the temperature difference between the temperature set on the control panel and the current room temperature. When the boiler is filled, the water is automatically heated as well. The water temperature will depend upon the operational mode and the heater output.

If the heater is not to be used when freezing conditions are expected the water system MUST be drained. NO warranty claim will be accepted for cases of frost damage.

Before using the heating system for the first time please ensure that the 12v system is turned ON at the control panel over the doorway and that the gas cylinder and isolation valve are turned on.

Fig opposite shows the controls for the Truma Combi Boiler

If the gas system is leaking or if there is a smell of gas:

- Extinguish all naked flames.
- Open all doors and windows.
- Close all quick-acting valves and gas cylinders
- Do not smoke
- Do not activate any electrical switches
- Ask an expert to inspect the entire system.

Repairs may only be carried out by a certificated repairer.

Any modifications to the unit, including the accessories, exhaust duct and cowl, or the use of spare parts and accessories that are important to the operation of the system that are not original Truma parts and failure to follow instructions will cancel any warranty and indemnify Truma of any liability claims. It also becomes illegal to use the appliance, and in some countries this even makes it illegal to use the vehicle.

The gas supply's operation pressure (30 mbar) must be the same as the unit's operating pressure (see type plate).

The vehicle owner is always responsible for arranging periodic inspections.

Liquefied gas equipment may not be used when refuelling, in multi storey car parks, in garages or on ferries.

During the initial operation of a brand new appliance (or after it has not been used for some time), a slight amount of fumes and smell maybe noticed for a short while. It is a good idea to heat the device up several times and to make sure that the area is well ventilated.

Heat-sensitive items such as aerosols or flammable liquids may not be stored in the same compartment as the heater because this area maybe subjected to high temperatures.



TRUMA CONTROL PANEL

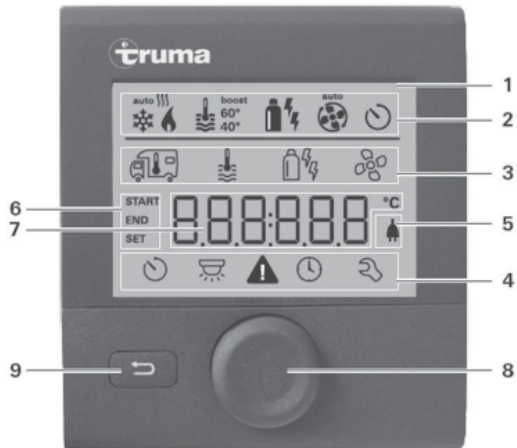

1 = Display

2 = Status line

3 = Menu line (above)

4 = Menu line (below)

5 = Display of mains voltage 230V (shore power)

6 = Display timer











EQUIPMENT DETAILS

FUNCTIONS







To switch on/off press the control knob for longer than 3 seconds. The boiler starts with the last selected settings.

Turn the control knob right or left to move through the menu and also to increase/ decrease values, click the control knob to select a menu item or accept a value.

Menu		Settings/Description	
	CHANGE THE ROOM TEMPERATURE		Heater Settable temperature range 5 - 30°C (1°C steps). This symbol will flash until the required room temperature is reached.
			CHANGE THE WARM WATER LEVEL
	SELECT POWER TYPE	boost	Targeted, fast heating of the content of the boiler. Once the water temperature is reached, the room is heated again.
		40°	Warm water temperature 40°C.
		60°	Warm water temperature 60°
			Gas
			EL1 - Electro
			EL2 - Electro
	Mix 1 (mixed mode) – Gas + Electro		
	Mix 2 (mixed mode) – Gas + Electro		

EQUIPMENT DETAILS



Menu		Settings/Description	
	SELECT FAN LEVEL (When the heater unit is connected)		Vent Circulating air, if no device is in operation, 9 speed levels can be selected.
			Eco Low fan level.
			Mid High fan level (only Combi Gas).
			Fast heating of the room. Available, if the difference between the selected and current room temperature is >10°C.
	SET TIMER	<ul style="list-style-type: none"> • Enter start time • Enter end time point • Set the room temperature • Set the warm water level • Select power type • Select fan level • Activate the timer The timer remains active, even for several days, until it is deactivated.	

Filling the Unit with Water

- Ensure that the cold water drain tap is closed (the level should be in the horizontal position).
- Turn on the hot tap in either the bathroom or the kitchen. Position the tap in the HOT position.
- Position the handles on the water pump so that it is directed into the heater.
- Leave the tap open to let the air escape from the water system while the tank is filling. The heater is full once the water flows from the tap. For more detailed information on operating the Truma Combi boiler please refer to TRUMA appliance instructions that can be found in your information wallet.

It is essential that you do not block/obstruct or cover the flue outlet from your Truma Combi Boiler.



EQUIPMENT DETAILS

ALDE HEATING - QUICK START GUIDE (TI & EB Models)

ALDE 3020 COMPACT HE CONTROL PANEL

The Alde 3020 Compact HE control panel has two hard buttons and a non-capacitive, colour touchscreen interface. The soft buttons displayed on the screen are operated by touching the screen with your finger.

Important! Please read the operating instructions for the Alde 3020 Compact HE boiler before using the system.

STARTING THE SYSTEM



1. Both the control panel and boiler are off.
2. To start the system, press the Power button on the control panel. The Splash Screen is displayed and green LED is lit. The boiler will now start with the previously saved settings (factory settings by default).

The system will now be drawing variable 0.2–1 A of current from the 12 V supply.

Standby Screen

The Standby Screen is displayed after the Splash Screen. This screen contains useful information about the status of your heating system.

NB: If Standby Screen is set to “Dark” in Backlight settings, the Standby Screen will not be displayed, the screen will be dark unless touched.

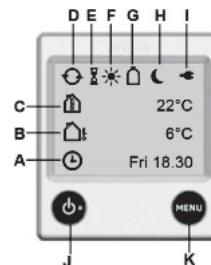

- A. Clock is enabled. Day of the week and time shown.
- B. Outdoor Temperature. [Optional outdoor temperature sensor required.]
- C. Room Temperature. Measured at the control panel. [Optional discrete room temperature sensors available.]
- D. Central heating circulation pump is active.
- E. Delayed Start/Cycle is enabled.
- F. Day Mode active.
- G. Gas Cylinder Status. Full/empty and active EisEx shown.
- H. Night Mode active.
- I. 230 V supply. If not displayed, the boiler is not receiving 230V supply.
- J. Power button. Press to switch system on-off. Lit green LED indicates system is on.
- K. MENU button. Press to access Main Menu from Standby Screen or Settings Menu. [Additional accessories required.]



MAIN MENU

Press MENU button to access the Main Menu from the Standby Screen or Settings Menu. The screen will revert to the Standby Screen after 30 secs if untouched.

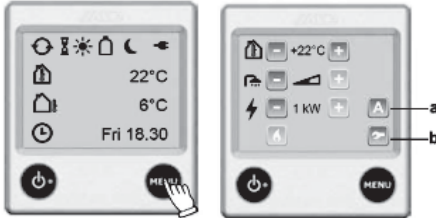

1. Standby Screen.
Press MENU button.
2. Main Menu.
 - a. What's Activated Menu. [Not displayed if no activated functions are detected.]
 - b. Settings Menu



Desired Room Temperature

The desired room temperature can be set from 5 to 30°C, in 0.5 increments.

Tip! The World Health Organisation recommends a room temperature of 18–24°C for healthy living.

NB: If Day or Night Mode are active, the temperature cannot be adjusted, the Plus and Minus buttons will be greyed out.

1. The current desired room temperature is displayed.
2. Adjust by pressing Plus or Minus button.



Domestic Hot Water

The Alde boiler stores 8.4 Litres of hot water as standard. If the hot water cylinder is empty, the air is heated but no damage can result.

Tip! In a good summer, for example, lower the desired temperature on the control panel to around 10°C. The central heating will not circulate (unless the temperature drops to 10°C), but you can still control hot water.

NB: If Day or Night Mode Sans Hot Water are active, the hot water cannot be adjusted, the Plus and Minus buttons will be greyed out.

1. Hot Water Ignore. Volume bar empty. No attempt is made to heat hot water specifically. This saves energy when the freshwater is drained down.
2. Hot Water Normal. Volume bar half-full. Hot water is heated to greater than 50°C.
NB: If Circulation Pump is set to Continuous, this option will not be available.
3. Hot Water Boost. Volume bar full. Central heating circulation is disabled for 30 mins. Hot water is heated to greater than 65°C. After 30 mins the system reverts to Hot Water Normal.
4. Adjust by pressing Plus or Minus button.



Electric Heating

Check that 230V supply is displayed on the Standby Screen. The Alde boiler is programmed to use power economically and there are times when it may use no power at all, even if set to 3 kW.

1. Select Off, 1, 2 or 3 kW electric heating. More power equals better performance, but may be restricted by the current (amps) limit on the electric hook-up.
2. Adjust by pressing Plus or Minus button.

Max current draw from 230 V supply is 4.5 A on 1 kW, 9 A on 2 kW, 14 A on 3 kW. If the electric supply has unstable voltage, the amperage will also fluctuate.



Gas Heating

The Alde boiler is programmed to use power economically. The gas burner has two stages, shifting dynamically between low or full flame. There are times when it may use no power at all, even if gas heating is selected.

1. Press the Flame button to select gas heating. Green is on, blue is off.

Use both gas and electric heating for best performance.



EQUIPMENT DETAILS



Climate Control

The AC button is displayed when a Truma Aventa Comfort air-conditioning unit is connected to the Alde control panel. This allows fully automatic climate control, with the heating and air-conditioning working in unison.

- Select the desired room temperature as normal.
- Press the AC button. Green is on, blue is off. The heating and air-conditioning will actively maintain the desired room temperature.

Alde recommends using the 3010-346 discrete room temperature sensor for accurate climate control. It should be located where the heating and air-con have a balanced effect on temperature.

Booster Fan

There are two additional fans located under the second row passenger seats. These are operated via an on/off switch within the seating area.

SHUTTING DOWN THE SYSTEM

To save energy, the control panel only updates the boiler after the last adjustment is made. Wait 10 secs before shutting down the system to ensure the boiler is updated.

1. Press the Power button again. The screen goes dark, the green LED is unlit. The system is off.

SETTINGS

To learn more about the Settings Menu and programmable features of your Alde heating system, the complete operating instructions can be downloaded from www.alde.co.uk.

To store programmable features between sites, the optional Alde 3010-420 AA battery backup is required.

SETUP

How you set up your system will depend on what accessories are installed and your user preferences. To get you started, here's how to setup some of the more common features.

Restore default factory settings

Before using the system for the first time, restore default factory settings. Your control panel may have been tested by the dealer or installer, and some settings may have been changed unintentionally.

1. Press Tool button to access the Settings Menu (bottom right in Main Menu).
2. Press down arrow, until Reset button is displayed.
3. Press the Reset button to proceed.



Setup 12V circulation pump in expansion tank

To use the 12V circulation pump in the expansion tank, you must set it up. This is not a default factory setting. NB: This only applies if you have the 12V circulation pump in the expansion tank.

1. Press Tool button to access the Settings Menu (bottom right in Main Menu).
2. Press down arrow, until Installed Accessories button is displayed.
3. Press the Installed Accessories button to access the menu. Find and tick "Optional Pump" by pressing the box. Next, find and untick "Main Manual 12V".





Setup Standby Screen for bedtime

The backlight on the Standby Screen can be disturbing if the control panel is visible from your bed. It can be inverted for white text on black background.

1. Press Tool button to access the Settings Menu (bottom right in Main Menu).
2. Press down arrow, until Backlight button is displayed.
3. Press Backlight button, select Inverted to proceed.



Setup Antimicrobial function

To actively kill *Legionella*, setup the Antimicrobial function. At 2:00 every night, the hot water will be heated to over 65°C for 30 mins. This further reduces the risk of *Legionella*.

1. Press Tool button to access the Settings Menu (bottom right in Main Menu).
2. Press down arrow, until Antimicrobial button is displayed.
3. Press Antimicrobial button to proceed.



TROUBLE SHOOTING

Any error messages will be displayed on the Standby Screen. Error messages can be cleared by switching off 12 V supply to the boiler for 10 secs.

The system is completely dead, the control panel is blank

- Check the 20 mm T3.15 Amp glass fuse in the boiler. This is located under the lid of the black plastic service hatch, in a green plastic fuse holder.
- Check the 12 V supply to the boiler, it should be above 12 V.
- Check the 12 V cable is plugged into the boiler. Check the cable is plugged into the Alde control panel.

The boiler will not ignite on gas, but no error message

- The system may not need to use gas heating if also using electric heating.
- The fluids in the boiler may already be at operating temperature.

The boiler will not heat on 230 V electric

- Check the circuit breaker and any 230 V fuses.
- Check that any 230 V fused spurs are on (they will often have an LED indicator and 230 V fuse).

- Check the 230 V supply (also indicated on the Standby Screen).
- The fluids in the boiler may already be at operating temperature.

No hot water

- Check that Hot Water Ignore is not activated on the Alde control panel.
- Check that Continuous pumping is not activated on the Alde control panel.
- Check for other conflicting settings on the Alde control panel or restore factory defaults.
- Check the water pump and cold water supply to the boiler.

No central heating

- Bleed the system of air.
- Check the fluid level in the expansion tank.
- Check that the circulation pump is responding.
- Check that hot water boost is not activated on the Alde control panel.
- If electric heating is not being used, set it to "Off" on the Alde control panel.
- Use gas and electric heating for best performance.
- Check that top and bottom vents in the furniture are not obstructed.
- Check the condition of the heat transfer fluid.



EQUIPMENT DETAILS

- Most vehicles will reach a comfortable temperature within 40 mins, in non-extreme conditions.

Circulation pump is noisy

- Bleed the system of air.
- Check the fluid level in the expansion tank.
- If the inline pump, check speed dial on pump is set to 2-3.

"Panel failure 1" & "Panel failure 2"

- Moisture is trapped in the control panel.
- Remove the Alde control panel from the vehicle and air in a warm, dry place overnight.

"Gas failure"

- Out of gas or gas is not igniting.
- Check the gas cylinder is full. Try a different gas cylinder, ensuring it is propane gas.
- Check the gas regulator and any isolation valves are open and not frozen.

"Overheat red fail" or "Overheat blue fail"

- Bleed the system of air.
- Check the fluid level in the expansion tank. It should be 1cm above min mark when cool.
- Check the correct circulation pump is installed, selected and responding.

- 12 V supply to the boiler dropped to 7 V momentarily. Check 12 V supply for stability.
- Wait 30 minutes for the fluid to cool down.

"Overheat PCB"

- Failsafe in boiler has triggered.
- Check the fluid level in the expansion tank. It should be 1 cm above the Min mark when cool.
- Check the boiler compartment is ventilated and that the vents are unobstructed. Do not place stowage in the boiler compartment.

"Fan failure"

- Combustion fan speed too low after multiple attempts. Bearing may be stiff after a period of disuse.
- Check for instability in 12 V supply.

"Connection failure"

- Loose connection between Alde control panel and boiler.
- Unplug cable at the control panel and boiler, then carefully plug back in.
- Check there is slack on the cable at the control panel, but not excessive weight from free-hanging/unmanaged cable.

"Window open"

- Optional window sensor has triggered, gas heating is suspended. Automatically clears and gas heating resumes when window is closed.

"3rd Party Panel C. Fail"

- Break in comms between Alde control panel and third party control panel.
- Check the cable between the Alde control panel and third party control panel.
- Third party control panel is installed in software but not fitted.
- Untick "Third Party Panel" in Installed Accessories Menu.

"Low battery"

- 12 V supply to boiler has dropped below 10.5 V, possibly causing system brownout.
- Automatically clears when 12 V supply reaches 11 V.

"No match Heater/Panel"

- EM interference from 230 V power, if cables are bundled together.
- Conductive dirt in socket. Plug Alde control panel cable into the alternative TIN bus sockets.

If problems persist, please contact Alde, or your dealer or installer.

For our frequently asked questions, or download all instruction manuals, please visit our web site at: www.alde.co.uk



REFRIGERATOR

Your new Motorhome is fitted with a Dometic refrigerator. Details of how to operate your fridge are shown opposite:

The refrigerator is equipped to operate on three power modes:

- Mains voltage (230V AC)
- Direct current voltage (12V DC)
- Gas (liquid gas, propane/butane)

Select the desired power mode by the energy selector switch (battery igniter type models) or the energy selector button (MES, AES). Appliances with automatic energy selection (AES) are additionally provided with "automatic mode" function. Then the AES system automatically selects the best energy source for each particular situation.

The cooling unit is silent in operation.

When the appliance is first put into operation, there may be a mild odour which will disappear after a few hours.

The refrigerator will take several hours to reach its operating temperature in the cooling compartment. The freezer compartment should be cold about one hour after switching on the refrigerator.

Cleaning

Before starting up the refrigerator, it is recommended that you clean it inside and repeat this at regular intervals.

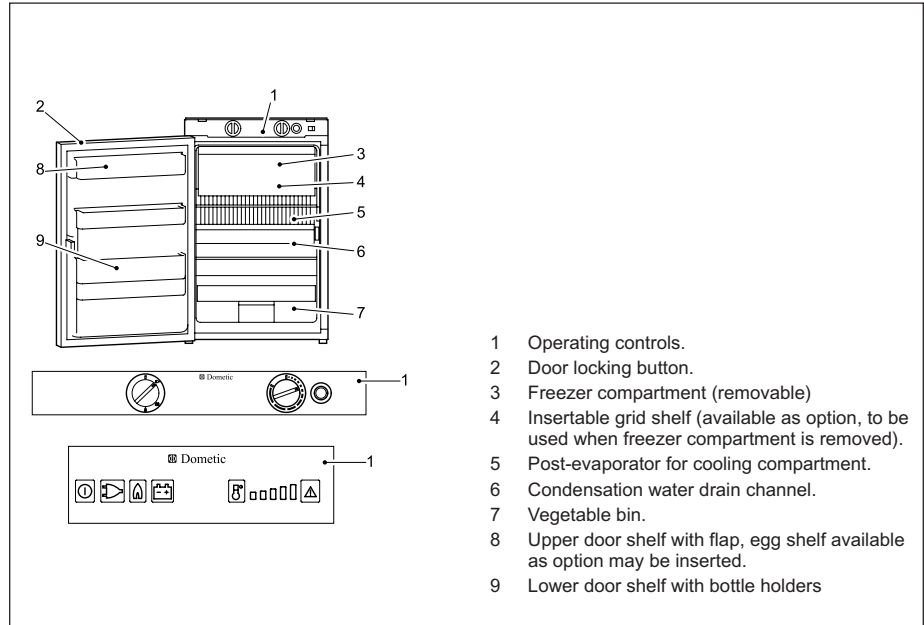

- 1 Operating controls.
- 2 Door locking button.
- 3 Freezer compartment (removable)
- 4 Insertable grid shelf (available as option, to be used when freezer compartment is removed).
- 5 Post-evaporator for cooling compartment.
- 6 Condensation water drain channel.
- 7 Vegetable bin.
- 8 Upper door shelf with flap, egg shelf available as option may be inserted.
- 9 Lower door shelf with bottle holders

Use a soft cloth and lukewarm water with a mild detergent. Then wipe out the appliance with clean water and dry thoroughly.

To avoid material alterations, do not use soap or hard, abrasive or soda-based cleaning agents. Do not allow the door seal to come into contact with oil or grease.

Maintenance

In compliance with applicable regulations, please note that the gas unit and the connected ventilation ducts must be checked by an authorised technical personnel after first use and after every other year for compliance with the European Standard EN 1949. A test certificate has to be issued. **It is the user's responsibility to arrange this test.**



EQUIPMENT DETAILS

The gas burner must be inspected and cleaned as necessary, at least once a year. When using liquefied petroleum gas (tank or refill cylinders) the maintenance interval is reduced to half-yearly or quarterly.

Keep the evidence of maintenance work carried out on your refrigerator.

Work on gas and electrical equipment shall be carried out by qualified personnel only.

It is recommended that this is carried out by an authorised customer services department.

We recommend maintenance following an extended shutdown of the vehicle. Please contact our customer services.

Electrical operation

12V voltage (on-board power supply)

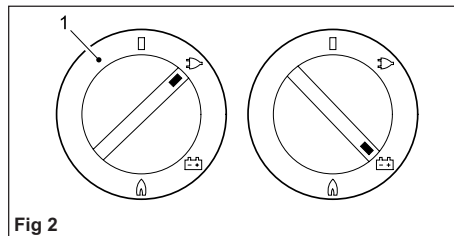

Fig 2

CAUTION: The refrigerator should only be used in 12V DC operation while the vehicle's engine is running, otherwise the on-board battery would be discharged within a few hours!

Appliances with battery igniter (manual energy selection)

Electrical operation

Switch on the appliance by turning the energy selection switch (1) clockwise to position:

 230V operation,

 12V operation

Gas operation (Liquid gas)

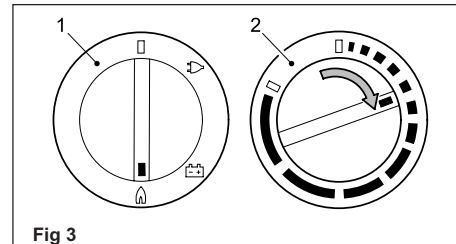



Fig 3

1. Turn the rotary selector switch (1) to position 
2. Turn the temperature selector (2) clockwise and push. Keep the controller button depressed.

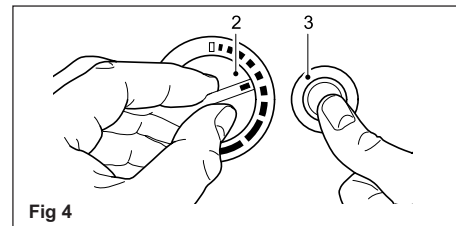

Fig 4

3. Then, press knob (3) of battery igniter down and keep it depressed. The ignition process is activated automatically.
4. The refrigerator is operational. Keep knob (2) depressed for approx. 15 seconds and finally release it.



Setting of cooling compartment temperature

Select the desired cooling compartment temperature by turning the rotary knob (2).

The scale starts with **MIN** position (small bar = highest temperature) and climbs up to **MAX** position (large bar = lowest temperature).

Note: The temperature levels do not relate to absolute temperature values.

12V: The refrigerator operates without thermostatic control (continuous operation).

Mains power (230V)

CAUTION: This option should only be selected where the supply voltage of the connection for power supply corresponds to the value specified on the data plate. Any difference in values may result in damage to the appliance.

Gas operation (Liquid gas)

- The refrigerator must be operated using liquid gas (propane, butane) (no natural gas or town gas).
- When using LPG gas, please consider that the burner needs cleaning at shorter intervals due to the gas combustion method (2-3 times per year recommended).
- In Europe, gas operation is permitted while travelling only on the condition that the gas system of the vehicle is equipped with a hose rupture protection. The national regulations of the respective country must be observed.

- For physical reasons, gas ignition faults could occur starting from an altitude above sea level of approx. 3280 ft. / 1000m (No malfunction).
- On the initial refrigerator start-up or after a cylinder change, air may be trapped in the gas line. To purge the air from the lines, switch on the refrigerator and any other gas appliances (e.g. stove) for a short time. The gas ignites without delay.
- Each refrigerator with manual ignition is equipped with an automatic flame safety valve which interrupts the gas supply automatically after approx. 30 seconds when the flame has extinguished.

WARNING: As a basic rule, gas operation is prohibited in petrol stations!

Prior to starting the refrigerator in gas mode:

- Open the gas cylinder valve.
- Open the shut-off valve for gas supply to the refrigerator.

Explanation of operating controls

Manual energy selection/automatic ignition on MES:

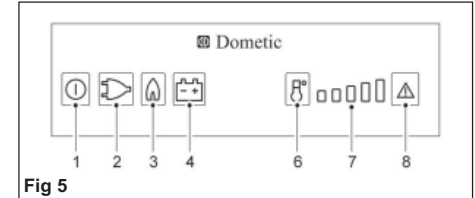

Fig 5

- 1 = Power ON/OFF switch
- 2 = Energy selector button 230V AC
- 3 = Energy selector button GAS
- 4 = Energy selector button 12V DC
- 6 = Temperature level selection
- 7 = Temperature level display
- 8 = Indicator LED failure/Reset button GAS FAILURE

Switching ON/OFF

Switch ON by pressing button (1), 2s

Switch OFF by pressing button (1), > 2s

230V AC operation

Select "Mains voltage" by pressing button (2)

Set temperature step by pressing button (6)

12V DC operation (vehicle's battery)

Select "Battery voltage" by pressing button (4)

Set temperature step by pressing button (6)



EQUIPMENT DETAILS

Gas operation

Select "Gas" by pressing button (3)

Set temperature step by pressing button (6)

MES appliances (manual energy selector)

Electrical operation

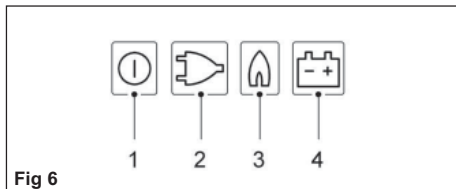

To start the refrigerator, press button (1) for 2 seconds.

The refrigerator starts with the last selected type of energy.

230V operation:

Press button (2): 

12V operation:

Press button (4): 

Gas operation

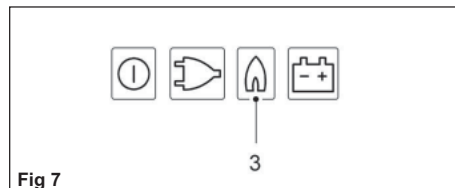

Gas operation:

Press button (3): 

The ignition process is activated automatically by means of an automatic igniter.

The flame extinguishes after reaching the preset cooling compartment temperature and ignites again if the cooling compartment temperature increases again. If the flame is not lit after the first ignition attempt, the automatic igniter repeats the ignition twice (duration 30 s) at time intervals of 2 minutes. If the flame is not lit afterwards, a fault is indicated.

Setting of cooling compartment temperature

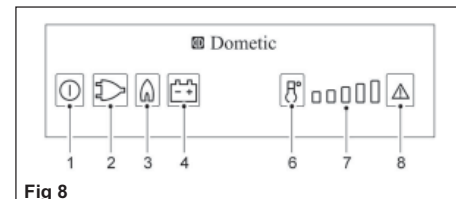

Select the desired cooling compartment temperature by pressing button (6).

The LED display (7) of the selected temperature re setting is illuminated.

The scale starts with MIN position at the left LED position (small bar = highest temperature) and climbs up to MAX position at the right LED position (large bar = lowest temperature).

Note: The temperature levels do not relate to absolute temperature values.



Door locking

Open the door by pressing the locking button and pull open.

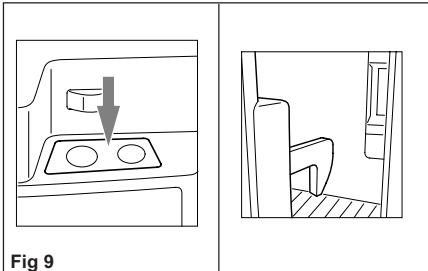

Fig 9

Shut the door again by pushing it to close. The snapping into the lock can be heard.

Note: If the vehicle is stationary for a long period, the locking hook may be clamped by means of a lockbar. The door may now be opened by just pulling it without need of pressing the locking button. See below.

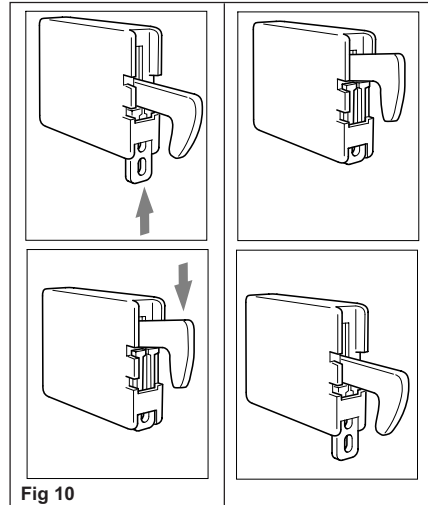

Fig 10

CAUTION: As a basic rule, shut and lock the door before starting your journey.

Positioning the shelves

The shelves may be pulled out by smoothly lifting them, and may be positioned as desired.

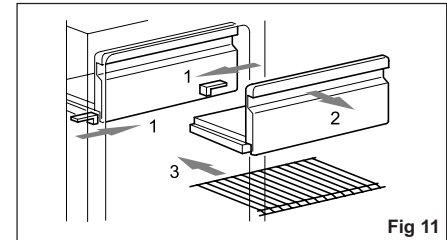

Fig 11

Removable freezer compartment

The freezer compartment may be removed to enlarge the cooling compartment.

Unlock the freezer compartment on both sides (1)

Pull the freezer compartment out (2) and store safely.

An additional shelf (3) may be installed, if required. This may be obtained from Dometic.

Storing food in the cooling compartment

- Switch the refrigerator on approx 12 hours before filling
- Always store pre-cooled food. Make sure that food is well cooled when it is bought and also when transporting it – use insulated cool bags.



EQUIPMENT DETAILS

- Keep the door open for the minimum time possible.
- Food must be packed, in closed containers or wrapped in foil, and stored separately from each other, to prevent drying out or odours.
- Allow foods that have been warmed to cool down before storing.
- Ensure that air circulation of the cooling unit is not obstructed. Keep the ventilation grilles free from obstructions.

Storing food in the freezer compartment

- Do not keep carbonated drinks in the freezer.
- The freezer compartment is suitable for making ice cubes and for short term storage of frozen foods. It is not suitable as a means of freezing foods.

Note: When ambient temperatures are lower than +10°C and the refrigerator is exposed to these temperatures for extended periods an even regulation of freezer temperature cannot be guaranteed for system-related reasons. This can cause the temperature in the freezer to rise and stored goods to melt.

Making ice cubes

Ice cubes are best made over night, when the refrigerator has less work to do and has more reserves.

Defrosting

In time, frost builds up on the fins inside the refrigerator. A layer of frost thicker on one side may occur but does not mean a malfunction. When this layer of frost is about 3mm thick, the refrigerator should be defrosted. To do this:

- Switch off the refrigerator as described later.
- Remove all food and the ice cube tray.
- Leave the door open to allow air to enter and prevent formation of mildew.
- After defrosting (freezer compartment and fins free of frost), wipe both cooling compartments dry with a cloth.

Note: Water thawing in the main compartment of the refrigerator runs into a container at the back of the refrigerator, from where it evaporates.

CAUTION: The layer of ice must never be removed forcibly, nor may defrosting be accelerated using a heat source.

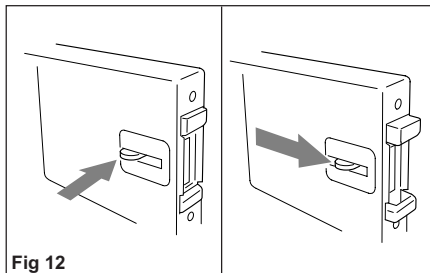

Fig 12

Shutting off the refrigerator

Press the mode button (1) and keep pressed for 2 seconds. The display will disappear and the appliance is fully switched off.

Release the locking mechanism of the door lock by pushing it and shift it to the front. If the door is shut in this position, a small gap is maintained to prevent the formation of mildew.

If the refrigerator is taken out of service for an extended period, close the isolation tap and the gas cylinder valve.

Winter operation

In winter, check that the ventilation grilles and the exhaust duct have not been blocked by snow, leaves etc. When the outside temperature falls below +10°C the winter covers should be fitted. This protects the unit from excessively cold air which could have adverse effects on the performance of the unit.





Note: The winter covers should also be attached if the vehicle is taken out of service for an extended period, or while it is being cleaned on the outside.

EQUIPMENT DETAILS



Failure display

Your refrigerator will indicate a malfunction by flashing of the failure indicator LED (4) and one of the other display lights. The chart below shows the meaning of these.

Display:	Failure:
 LED is flashing	230V mode: "230V" not available or voltage too low
 LED is flashing	12V mode: "12V" not available or voltage too low
 LED is flashing	GAS/Auto mode: Flame not ignited
All temperature setting LEDs are flashing	Temperature sensor defective, refrigerator work on mid temperature setting
 LED + all temperature	230V - Heating element defective
 LED + all temperature	12V - Heating element defective setting LEDs are flashing



EQUIPMENT DETAILS

Troubleshooting

Before contacting your dealer or authorised service centre, please check whether:

- The instructions for correct operation of the refrigerator have been observed.
- The refrigerator is standing level.
- It is possible to operate the refrigerator with any available power source.

Failure: The refrigerator does not cool sufficiently

Possible cause

Action you can take

- | | |
|---|--|
| • Inadequate ventilation to the unit. | • Check that the ventilation grilles are not covered. |
| • Thermostat setting is too low. | • Set thermostat to a higher level. |
| • The condenser is heavily frosted. | • Check that the refrigerator door closes properly. |
| • Too much warm food has been stored within short period of time. | • Allow warm food to cool down before storage. |
| • The appliance has been running for only a short period of time. | • Check whether the cooling compartment works after approx. 4-5 hrs. |
| • Ambient temperatures too high. | • Regularly remove ventilation grilles. |

Failure: The refrigerator does not cool in gas operation mode

Possible cause

Action you can take

- | | |
|---|---|
| • Gas cylinder empty. | • Change gas cylinder. |
| • Is the upstream shut-off device open? | • Open shut-off device. |
| • Air in the gas pipe? | • Switch off the appliance and start again.
Repeat this procedure 3-4 times, if necessary. |



Failure: The refrigerator does not cool in 12V operation

Possible cause

- On-board fuse defective.
- On-board battery discharged.
- Engine not running.
- Heating element defective (please also refer to failure indication).

Action you can take

- Fit new fuse.
- Check battery, charge it.
- Start engine.
- Please inform the Dometic Customer Services.

Failure: The refrigerator does not cool in 230V operation

Possible cause

- On-board fuse defective.
- Vehicle not connected to mains supply voltage.
- Heating element defective (please also refer to failure indication).

Action you can take

- Fit new fuse.
- Make a connection to a mains power supply.
- Please inform the Dometic Customer Services.



EQUIPMENT DETAILS

ASPIRE 2 DUEL FUEL OVEN (Roadstar Models)

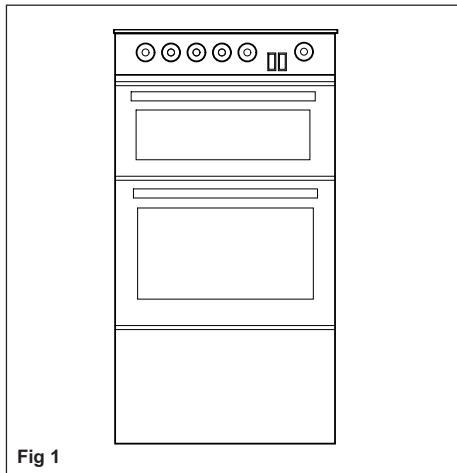

Fig 1

To light: Open door, push in the control knob and turn to full rate (240°C). Hold a lighted match or taper to the burner and push the control knob in and hold. The burner should ignite and the control knob should be held in for 10-15 seconds before release. If the burner goes out, repeat procedure holding control knob for slightly longer.

For models fitted with spark ignition the procedure is similar except that the burner can be ignited by depressing the ignition

button, which is located on the fascia. Ignition must be carried out with the door open, and if the burner has not lit within 15 seconds the control knob should be released and the oven left off at least one minute before a further attempt to ignite the burner.

Place the oven shelf in the required position and close the door. Set control knob to approximately 200°C and heat the oven for about 30 minutes to eliminate any residual factory lubricants that might impart unpleasant smells to the meals being cooked. A non-toxic smoke may occur when using for the first time so open any windows and turn on mechanical ventilators to help remove the smoke.

Although the oven does heat up quickly, it is recommended that a 10 minute preheat be allowed. The oven should be up to full temperature in about 15-20 minutes.

To turn off: turn the control knob until the line on the control knob is aligned with the dot on the control panel.

Shelf: The shelf has been designed to allow good circulation at the rear of the oven and are also fitted with a raised bar to prevent trays or dishes making contact with the back of the oven. To remove a shelf, pull forward until it stops, raise at front and remove.

Hotplate burners

Ensure the gas cylinder is turned on.

In the event of a gas smell turn off at the cylinder and contact supplier.

Flame supervision: each burner is controlled individually and is monitored by a thermocouple probe. In the event of the burner flames being accidentally extinguished, turn off the burner control and do not attempt to re-ignite the burner for at least one minute.

Note:

- Depending on the specification of your appliance it may be fitted with a glass lid which cuts the power to the hotplate and burners (gas and electric) if the lid is closed.
- Ensure the glass lid is in the open and upright position before turning on the hotplate burners.
- Not all models are fitted with the shut-off system.



Grill

Operation

To light the grill, push in the control knob and turn to full rate (see Fig 2). Hold a lighted match or taper to the burner and push the control knob in and hold. It is necessary to hold the knob depressed after the burner has ignited for approximately 10-15 seconds, to allow the thermocouple probe to reach temperature, before releasing the knob. Should the flame go out when the knob is released, the procedure should be repeated holding the knob depressed for slightly longer.

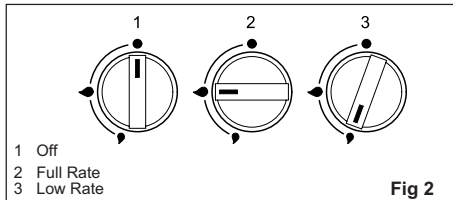

For models fitted with spark ignition the procedure is similar except that the burner can be ignited by depressing the ignition button, which is located on the fascia. If the burner has not lit within 15 seconds the control knob should be released and the burner left for at least one minute before a further attempt to ignite the burner.

For simmering, turn the knob further anti-clockwise to the low rate position.

To turn off: Turn the control knob until the line on the control knob is aligned with the dot on the control panel. Always make sure the control knob is in the off position when you have finished using the hotplate burners.

IMPORTANT:

- Each burner will support pans from 10 to 22 cm diameter, care should be taken not to overload the appliance as performance may be reduced.
- The following pan sizes are the maximum we recommend: electric hotplate 18cm dia, auxiliary burner 20cm dia, semi-rapid burner 2x20cm dia or 1x22cm dia with 1x18cm dia.
- When using small pans the flames should not spread beyond the base of the burner.
- Avoid old or misshapen pans as these may cause instability.
- The lid must be opened fully prior to using the hotplate burners.

Using the Electric Hotplate

Ensure the electricity is switched on. The hotplate control is numbered from 1 to 6. To turn it on, rotate the knob either clockwise or anti-clockwise to the required position. Position 1 is the coolest setting. To turn off, rotate the knob until the line or pointer on the knob lines up with the zero on the control panel.

The hotplate is a sealed construction and transfers heat through conduction. For maximum efficiency a correctly sized pan with a flat heavy gauge base should be used. Pan size should be the same or slightly larger (up to 2.5cm oversize).

The grill

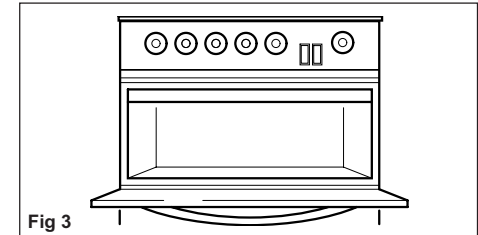

Fig 3

1. Ensure gas cylinder/supply is connected and turned on. In the event of a gas smell turn off at gas cylinder/mains and contact supplier.
2. To light: Open door, push in the control knob and turn to full rate (see Fig 2). Hold a lighted match or taper to the burner and push the control knob in and hold. The burner should ignite and the control knob should be held in for 10-15 seconds before release. If the burner goes out, repeat procedure holding control knob for slightly longer.
3. For models fitted with spark ignition the procedure is similar except that the



EQUIPMENT DETAILS

burner can be ignited by depressing the ignition button, which is located on the fascia. Ignition must be carried out with the door open, and if the burner has not lit within 15 seconds the control knob should be released and the grill left for at least one minute before a further attempt to ignite the burner.

- Note:** The grill must only be used with the door open.
- On first use of the grill, it should be heated for about 20 minutes to eliminate any residual factory lubricants that might impart unpleasant smells to the food being cooked. A non-toxic smoke may occur when using for the first time so open any windows and turn on mechanical ventilators to help remove the smoke.
- Although the grill does heat up quickly, a few minutes preheat is recommended.
- Flame Failure Device (FFD): The grill burner is fitted with a flame sensing probe, which will automatically cut off the gas supply in the event of the flame going out. In the event of the burner flames being accidentally extinguished, turn off the burner control and do not attempt to re-ignite the burner for at least one minute.
- It is normal for the flames on this burner to develop yellow tips as it heats up, particularly on butane.

- A reversible grill pan trivet enables the correct grilling height to be achieved.

Fast toasting	trivet in high position
Grilling sausages	trivet in high position
Grilling steak/bacon	trivet in high position
Grilling chops, etc.	trivet in low position
Slow grilling	trivet removed

- To turn off, turn the control knob until the line on the control knob is aligned with the dot on the control panel. Always make sure the control knob is in the off position when you have finished grilling.

Notes:

- The grill pan supplied is multi functional, for use in grill or oven.
- The handle design allows removal or insertion whilst the pan is in use.
- Always remove the handle when the pan is in use,
- The grill **MUST** only be used with the door open.

CAUTIONS:

- Children should be supervised to ensure they do not play with the appliance.
- Do not use foil on the oven shelves, as this creates a fire hazard and can hinder circulation of heat.
- Ensure gas cylinder/supply is connected and turned on. In the event of a gas smell turn off at gas cylinder/mains and contact supplier.

- Spillage on the surface of the lid should be removed before opening the lid.
- Do not use foil on the hob, as it creates a fire hazard.
- The glass lid has a tendency to snap shut towards the end of lowering. This is caused by the travel lock action of the hinges as it is activated. Make sure all fingers are removed from appliance when closing the lid.
- Glass lids may shatter when heated. Turn off the hotplate and allow it to cool before closing the glass lid.
- Turn off all burners and allow to cool before shutting the lid.

WARNINGS:

- When the grill is being used, accessible parts may be hot, young children must be kept away.**
- The grill area can get hot when the oven is in use, even if the grill is switched off.**
- Care should be taken when removing parts from the grill, i.e. use of oven gloves, and by making use of the removal grill pan handle.**



DO'S AND DON'TS

DO read the user instructions carefully before using the appliance for the first time.

DO allow the oven to heat fully in order to expel any smells before introducing food for the first time.

DO clean the appliance regularly.

DO provide additional ventilation, such as opening windows near grill, cooker and oven when cooking.

DO remove any spills as soon as they occur.

DO use oven gloves when removing food shelves and trays from a hot oven.

DO check the controls are in the off position when finished.

DO NOT allow fats or oils to build up in the oven trays or base.

DO NOT use abrasive cleaners or powders that will scratch the surface of the hot plate and oven.

DO NOT under any circumstances use the oven as a space heater.

LEAKS

If a smell of gas becomes apparent, the supply should be turned off at the cylinder immediately.

Extinguish naked lights including cigarettes and pipes. Do not operate electrical switches. Open all doors and windows to disperse gas escapes.

Butane/Propane gas is heavier than air and escaping gas will collect at a low level. The strong unpleasant smell of gas will enable the general area of the leak to be detected. Check that the gas is not escaping from an unlit appliance.

Never check for leaks with a naked flame; leak investigation should be carried out using a leak detector spray or soapy solution.

MAINTENANCE

This appliance needs little maintenance other than cleaning. All parts should be cleaned using warm soapy water. Do not use abrasive cleaners, steel wool or cleansing powders. When cleaning the burner ring it is essential that the holes do not become blocked. The control knobs are a push fit and can be removed for cleaning. They are interchangeable without affecting the method of operation.

THIS APPLIANCE MUST NOT BE MODIFIED OR ADJUSTED UNLESS AUTHORISED AND CARRIED OUT BY THE MANUFACTURER OR HIS REPRESENTATIVE. NO PARTS OTHER THAN THOSE SUPPLIED BY THE MANUFACTURER SHOULD BE USED ON THIS APPLIANCE.



EQUIPMENT DETAILS

CK2000 CIRCULAIR

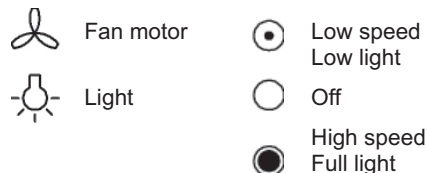
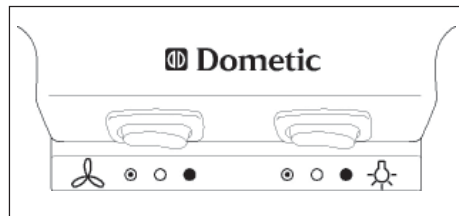

To turn the cooker hood on/off

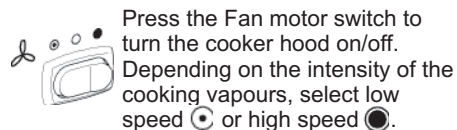

To turn the light on/off

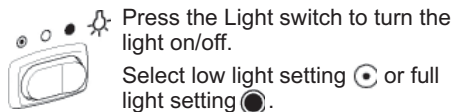

WARNING: Do not flambe food under the cooker hood.

Some tips and advice

- Using the low light option will extend the life of the lamps.
- Always turn hood ON when cooking at high heat. You will find it helpful to turn the cooker hood on a few minutes before you start cooking. This starts to move the air in the kitchen and will speed up the elimination of cooking odours.
- It is advisable to run the fan for a few minutes after cooking is finished to neutralise any lingering odours in the air.

WARNING: Always disconnect the cooker hood from the mains supply before cleaning or changing any parts.

CLEANING

GENERAL INSTRUCTIONS

Please observe that the surfaces and controls are susceptible to scratches and abrasions. All external surfaces and controls can be cleaned using warm water with a little washing-up liquid applied with a sponge or cloth. Wipe the surfaces dry using a soft cloth.

Do not use cleaning agents containing soda, acids, chlorides or solvents. Avoid abrasive cleaning agents, e.g. powder cleaners or cream cleaners and abrasive sponges as these will damage the surface material.

CLEANING THE GREASE FILTER

The filter absorbs grease in cooking fumes and requires cleaning now and then. How often depends on how much the cooker is used and for how much the fan is in operation.

Remove and clean the filter regularly and do not wait until the suction power of the fan begins to decrease noticeably. Note that an oversaturated filter is a fire hazard.

The grease filter is mounted on the bottom cover.

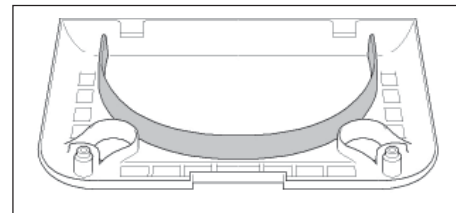



TO CLEAN THE FILTER, FOLLOW THESE STEPS:

1. Disengage the bottom cover as described in "Installation procedure", steps 1-3.
2. Observe how the filter is installed before removing. Lift filter straight up to remove.

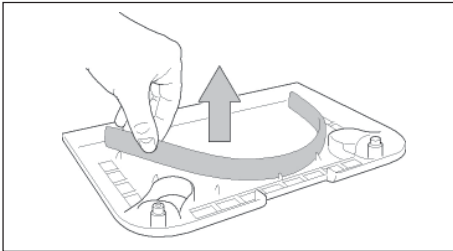

3. Clean the filter. Either by hand, using a soft nylon brush, warm water and a little washing up liquid - or - in a dishwasher where the filter should be placed with the short side upright in the lower basket, ensuring the spray arm is not obstructed. Wash using a 65°C (145-150°F) programme.

Depending on the cleaning agent used, cleaning the filters in a dishwasher can cause permanent discolouration to the surface. However, this will not affect the functioning of the filters in any way.

4. Allow the filter to dry.
5. Put back the filter.

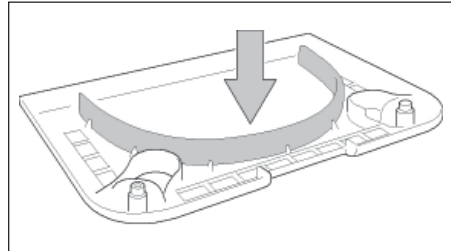

6. Put back the cover and secure with the two screws and washers.

REPLACING THE CARBON FILTER

The carbon (charcoal) filter is used to neutralise odours when your hood is recirculating air around the living area.

The charcoals, many small pores, form a very fine filter. Many gases are carbon based and thus, charcoal filters are very good at removing odours, such as cigarette smoke, cooking odours, and fumes. Over time the carbon filter becomes less efficient, because the small pores in the charcoal gradually get filled. The carbon filter therefore needs at some stage to be replaced. Under normal operating conditions it should be replaced every 6 months.

The carbon filter is mounted on the middle cover.

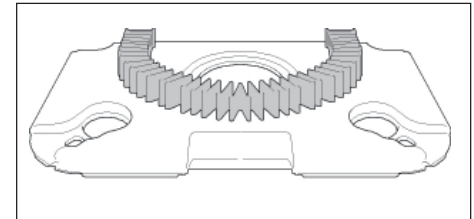



EQUIPMENT DETAILS

TO REPLACE THE FILTER, FOLLOW THESE STEPS:

1. Disengage the bottom and middle covers as described in "Installation procedure", steps 1-4.
2. Observe how the filter is installed before removing. Lift filter straight up to remove.

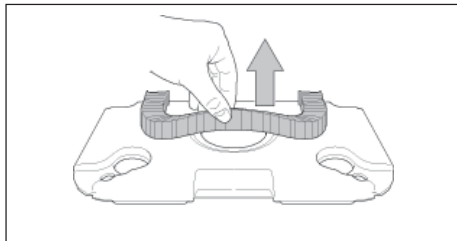

3. Replace with a new filter. Note that the carbon filter must be in place for the cooker hood to operate.

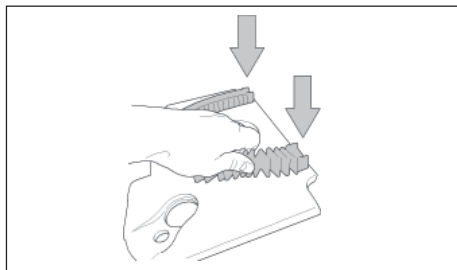

4. Reinstall the middle cover and snap into place.
5. Reinstall the bottom cover and secure with the two screws.

CHANGING THE HALOGEN LAMP

Halogen lamps get very hot during use and remain hot for some time after being switched off. Please allow the halogen lamps to cool before removing.

TO CHANGE THE LAMP, FOLLOW THESE STEPS:

1. The lamps are mounted on the top cover. In order to replace the lamps you need to disengage the bottom and middle covers. For instructions, see "Installation procedure", steps 1-4.
2. Gently pull to remove the lamps from their sockets.
3. Replace with halogen lamps of the same specification (10W, 12V GU4) and put back the cover.

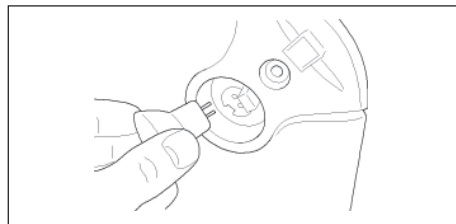

WASTE MANAGEMENT

Appliances bearing this symbol must be deposited at the designated local reception point for the disposal of electrical and electronic equipment. It is not permitted that this product be disposed of by way of the normal household refuse collection system.

IMPORTANT: Users are advised not to leave a bare flame burning below the CK2000 for longer than necessary (5-10 minutes maximum).



SPINFLO DUPLEX COMBI OVEN Cassini Models

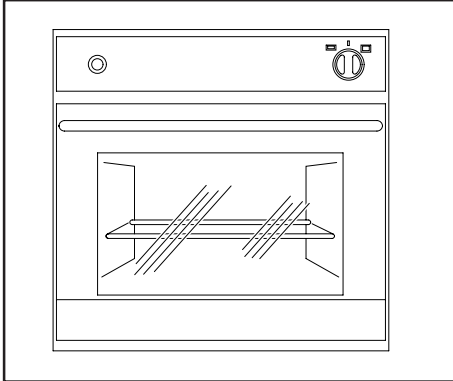

Using the Grill

- (1) Ensure gas supply is connected and turned on.
- (2) Open door, push in the control knob and turn clockwise to full rate - large flame ().
- (3) Light burner with match, keeping the control knob held in for 10 - 15 seconds - models with Spark Ignition the procedure is similar except burner ignited by depressing the ignition button.
- (4) Release knob and turn to required heat setting.

- (5) If burner has not lit within 15 seconds, release knob and wait at least 1 minute before repeating operations (2) to (4).
- (6) To turn off, rotate the control knob until the line on the knob is aligned with dot on the control panel.
 - The pan supplied with the appliance is multi-functional, for use either whilst grilling or when using the oven.
 - The pan handle can be removed or inserted whilst pan is in use. Always remove the handle when the pan is in use.
 - The control tap on this appliance operates both the Grill and Oven burners. To ensure safe operation it is not possible to operate both burners at the same time.

WARNINGS

- **The grill MUST only be used with the grill door open.**
- **The heat deflector below the fascia should be pulled out prior to lighting the grill. Never adjust the heat deflector position without using hand protection - ie oven gloves.**
- **When cooking always ensure young children are kept away.**

Using the Oven

- (1) Ensure gas supply is connected and turned on.
- (2) Open door, push in the control knob and turn anti-clockwise to gas mark 9.
- (3) Light burner with match, keeping the control knob held in for 10 - 15 seconds - for models with spark ignition the procedure is similar except burner ignited by depressing the ignition button.
- (4) Release knob and turn to required heat setting.
- (5) If burner has not lit within 15 seconds, release knob and wait at least 1 minute before repeating operations (2) to (4).
- (6) Place the oven shelf in the required position and close the door.
- (7) To turn off, rotate the control knob until the line on the knob is aligned with the dot on the control panel.

Before first time use, heat the oven at gas mark 5 for 30 minutes to eliminate any residual factory lubricants, open windows to assist in removal of any unpleasant smells or smoke.

Although the oven does heat up quickly, it is recommended that a 10 minutes preheat be allowed. The oven should reach full temperature in 15 - 20 minutes.



EQUIPMENT DETAILS

The shelf has a raised bar to prevent dishes making contact with the back of the oven and to allow good circulation at the rear of the oven. To remove a shelf, pull forward until it stops, raise at front and remove.

Oven Temperature Control

The oven temperature is controlled by a thermostatic gas tap and is variable over the range 130°C to 240°C. The temperature settings on the control knob refer to the centre of the oven and at any particular setting the oven will be hotter at the top and cooler towards the base. The variation between top and centre, and centre to bottom is approximately equivalent to one gas mark. Care should be taken not to overload the oven, ensure adequate spacing when cooking more than one item to allow free circulation of heat.

WARNING

Never cover slots or holes in the oven or cover a shelf with materials such as aluminium foil. Doing so restricts airflow and may cause carbon monoxide poisoning.

DO'S AND DON'TS

DO read the user instructions carefully before using the appliance for the first time.

DO allow the oven to heat before using for the first time, in order to expel any smells before the introduction of food.

DO clean the appliance regularly.

DO remove any spills as soon as they occur.

DO use oven gloves when removing food shelves and trays from a hot oven.

DO check the controls are in the off position when finished.

DO NOT allow children near the cooker when in use. Turn pan handles away from the front so that they cannot be caught accidentally.

DO NOT allow fats or oils to build up in the oven trays or base.

DO NOT use abrasive cleaners or powders that will scratch the surface of the appliance.

DO NOT under any circumstances use the oven as a space heater.

DO NOT put heavy objects into open grill and oven doors.

LEAKS

If a smell of gas becomes apparent, the supply should be turned off at the cylinder **immediately**.

Extinguish naked lights including cigarettes and pipes. Do not operate electrical switches. Open all doors and windows to disperse gas escapes.

Butane/Propane gas is heavier than air and escaping gas will collect at a low level. The strong unpleasant smell of gas will enable the general area of the leak to be detected. Check that the gas is not escaping from an unlighted appliance.

Never check for leaks with a naked flame; leak investigation should be carried out using a leak detector spray.

MAINTENANCE

This appliance needs little maintenance other than cleaning. All parts should be cleaned using warm soapy water. Do not use abrasive cleaners, steel wool or cleansing powders. When cleaning the burner ring it is essential that the holes do not become blocked. The control knobs are a push fit and can be removed for cleaning.



Thetford 3 Burner Hob

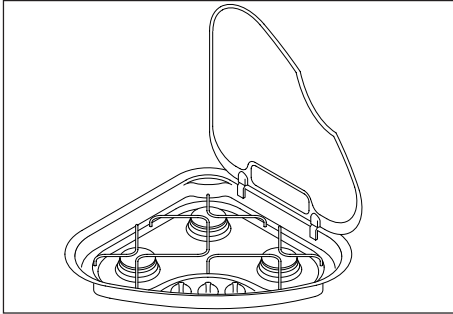

This appliance is designed for cooking food, any other use is incorrect and dangerous. Failure to install the appliance correctly or improper use could invalidate any warranty or liability claims and lead to prosecution.

Ventilation

The use of a gas cooking appliance results in a production of heat and moisture in a room in which it is installed. Ensure that the kitchen is well ventilated. Keep natural ventilation holes open or install a mechanical ventilation device, (mechanical extractor hood).

Prolonged intensive use of the appliance may call for additional ventilation, for example opening a window.

The appliance must be positioned free from draughts, which may affect the combustion in

a manner that will prevent the accumulation of unburnt gas. When in use ensure that air vents are not inadvertently blocked or shut off.

Burner Operation

The burners on the appliance have fixed aeration and no adjustment is required. The burners should flame as follows:

Propane - The flames should burn quietly with a blue/green colour with no sign of yellow tips.

Butane - Normally on initial lighting, a small amount of yellow tipping will occur and then slightly increases as the burner heats up.

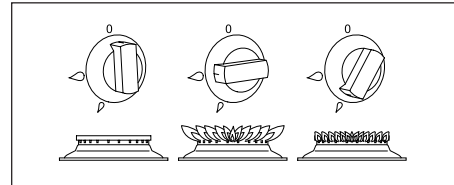

IMPORTANT

- **Series 330** - will support 200mm Ø pans on the outer burners and 180mm Ø pan on the central burner.
- **Avoid old or misshapen pans as these may cause instability.**
- **The lid must be opened fully prior to using the hotplate burners.**

1. Ensure gas cylinder/supply is connected and turned on. In the event of a gas smell turn off at gas cylinder/mains and contact supplier.
2. Flame supervision: Each burner is controlled individually and is monitored by a thermocouple probe. In the event of the burner flames being accidentally extinguished, turn off the burner control and do not attempt to re-ignite the burner for at least one minute.
3. To light: Push in the control knob and turn to full rate. Hold a lighted match or taper to the burner and push the control knob in and hold. It is necessary to hold the knob depressed after the burner has ignited for approximately 10 - 15 seconds, to allow the thermocouple probe to reach temperature, before releasing the knob. Should the flame go out when the knob is released, the procedure should be repeated holding the knob depressed for slightly longer.
4. For models fitted with optional Spark Ignition the procedure is similar:

Models with Auto Spark Ignition - pushing the control knob automatically starts the spark ignition circuit. To light the burner follow the procedure in (3) above, except that the burner can be ignited by depressing the ignition button located on the fascia.



EQUIPMENT DETAILS

Models with Manual Spark Ignition - follow the procedure in (3) above, except that the burner can be ignited by depressing the ignition button located on the fascia.

If the burner has not lit within 15 seconds the control knob should be released and the burner left for at least 1 minute before a further attempt to ignite the burner.

- For simmering, turn the knob further anti-clockwise to the low rate position.
- To turn off: Turn the control knob until the line on the control knob is aligned with the dot on the control panel. Always make sure the control knob is in the off position when you have finished using the hotplate burners.

WARNING

The Glass lid has the tendency to snap shut towards the end of lowering. This is caused by the travel lock action of the hinges as it is activated. Make sure all fingers are removed from appliance when closing the lid.

DO'S AND DON'TS

DO read the user instructions carefully before using the appliance for the first time.

DO allow burners to heat before using for the first time, in order to expel any smells before the introduction of food.

DO clean the appliance regularly.

DO remove spills as soon as they occur.

DO check that controls are in the off position when finished.

DO NOT allow children near the appliance when in use. Turn pan handles away from the front so that they cannot be caught accidentally.

DO NOT allow fats or oils to build up in the base of the hotplate.

DO NOT use abrasive cleaners or powders that will scratch the surfaces of the hotplate.

DO NOT under any circumstances use the appliance as a space heater.

LEAKS

If a smell of gas becomes apparent, the supply should be turned off at the cylinder **immediately**.

Extinguish naked lights including cigarettes and pipes. Do not operate electrical switches. Open all doors and windows to disperse any gas escape. Butane/Propane gas is heavier than air, any gas escaping will therefore collect at low level. The strong unpleasant smell of gas will enable the general area of the leak to be detected. Check that the gas is not escaping from an unlit appliance. Never check for leaks with a naked flame; leak investigation should be carried out using a leak detector spray or soapy solution.



Microwave (Daewoo)

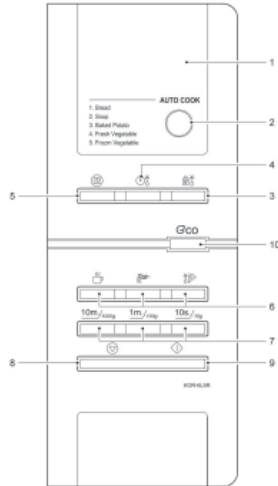

- 1 **DISPLAY** - Shows cooking time and power levels.
- 2 **AUTO COOK** - Use to cook or reheat common foods.
- 3 **WEIGHT DEFROST** - Defrost food based on weight.
- 4 **TIME DEFROST** - Defrost food by time.
- 5 **POWER** - Use to set power level.
- 6 **ONE TOUCH COOK** - Cook or reheat specific quantities of food.
- 7 **TIME SET BUTTON** - Set the cooking time and weight.
- 8 **STOP/CLEAR** - Stop the oven operation or delete the cooking data.
- 9 **START/+30 SEC** - Start the oven and also use set a reheat time.
- 10 **ECO** - Used to turn the AC power on the oven.

Operation Procedure

- Plug power supply cord into 230V AC 50Hz power outlet.
- Press eco button until beep sounds and display is turned on.
- After placing the food in a suitable container, open the oven door and put it on the glass tray. The glass tray and roller guide must always be in place during cooking.
- Close the door. Make sure that it is firmly closed.
- The oven door can be opened at any time during operation by pushing the door open button. The oven will automatically shut off. To restart the oven, close the door and then push the START button.
- The oven automatically cooks on full power unless set to a lower power level.
- The display will show ": 0" when the oven is plugged in, press and hold Eco button until display is turned on and beep sounds.
- Display will be returned to the ": 0" when the cooking time ends.
- When the STOP/CLEAR button is pushed during the oven operation, the

oven stops cooking and all information retained. To erase all information, push the STOP/CLEAR button once more.

- If the START button is pushed and the oven does not operate, check the area between the door and door seal for obstructions and make sure the door is closed securely. The oven will not start cooking until the door is completely closed or the program has been reset.
- Display turns off after 10 minutes.

Make sure the oven is properly installed and plugged into the electrical outlet.



EQUIPMENT DETAILS

THETFORD C-260 CASSETTE TOILET

INTRODUCTION

The Thetford Cassette Toilet is a high quality product. It is user-friendly, meets high quality standards and gives you all the convenience of home.

Before operating and using this toilet we advise you to read the manual completely. Keep this manual in a safe place for future reference.

For the latest version of the manual please visit www.thetford-europe.com



Standard

1 Cover - 2 Seat - 3 Swivelling toilet bowl - 4 Blade handle to open/close blade - 5 Control panel - 5a Flush button - 5b Waste-holding tank level indication (1 level or 3 levels; dependent on model) - 6 Pull handle - 7 Pour out spout - 8 Cap with measuring cup - 9 Automatic pressure release vent - 10 Vent button - 11 Sliding cover - 12 Blade opener - 13 Waste-holding tank mechanism - 14 Wheel - 15 Service door 3

Options

18 - Filter for electric ventilator - 19 Location waste pump-out system



Preparing for use

This Cassette Toilet has a waste-holding tank of 17.5L. Before using your toilet, it is vital that you add toilet additives to these tanks. Check the correct dosage on the additive package. Then add $\pm 3L$ of water to the waste holding tank.

Use of your toilet

Turning the bowl



You can turn this bowl to a desired position (max $\pm 90^\circ C$). Close the cover and use both hands to rotate the bowl as illustrated.

Opening the blade



The toilet can be used with the blade open or closed. To open the blade, slide the blade handle sideways as illustrated. Make sure you always close the blade completely after use.

Electric Blade (if applicable)

Press the flush button to activate the control panel. Then push the Electric Blade button. The blade will open or close electrically.

Flushing the toilet

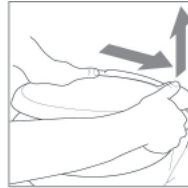

Press the flush button once to activate the control panel. Then press the flush button for several seconds to flush the toilet.

Electric Ventilator (if applicable)

By activating the control panel, the Electric Ventilator will start automatically; it will shut off automatically after about 5 minutes. The Electric Ventilator button will flash to show that this function is active. To stop the ventilator, press the Electric Ventilator button. Press the button again to re-start the ventilator. To optimise its function, activate the Electric Ventilator before you use your toilet.

Ordinary toilet paper can cause clogging. Use Aqua soft toilet paper instead. This toilet paper is super-soft, dissolves quickly, prevents clogging and makes it easier to empty the waste-holding tank.

Level indication

You can check whether your waste-holding tank has a 1-level or a 3-level indication. Make sure the tank is empty and place it back properly. Then activate the control panel. If no level indication light lights up,

your toilet has a 1-level indication. It will only indicate a full tank. If a green level indication light immediately lights up, your toilet has a 3-level indication. It will indicate empty, half full and full.

Emptying the tank

Waste holding tank

When the red light of the level indicator on the control panel lights up, you need to empty the waste-holding tank. Remove the tank via the service door. Then take it to an authorised waste disposal point. Empty the waste holding tank via the pour out spout.

Tip: To empty the tank without splashing, press and hold the vent button with your thumb while the pour out spout is pointing downwards.

Waste Pump-out system (if applicable)

By activating the control panel, this button automatically lights up. Press the button to empty the waste-holding tank into the vehicle's central waste tank. The button flashes while the waste is being pumped and stops flashing when all waste has been transferred. ($\pm 1.5L$ of waste is left). If the central waste tank is too full (only measured when this tank has a level indicator), the button flashes rapidly and no pump-out is possible until you have emptied the central waste tank.



EQUIPMENT DETAILS

CLEANING AND MAINTENANCE

It is important to clean this Cassette Toilet regularly. You will prevent limescale and ensure optimal hygiene. Clean the inside of the bowl with toilet bowl cleaner and a soft brush and use bathroom cleaner for the outside of the toilet.

Note: Never use household cleaners to clean your toilet. These may cause permanent damage to the seals and other toilet components.

Remove seat & cover

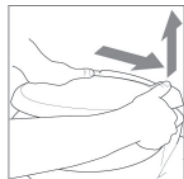

To clean your toilet thoroughly, remove the seat and cover. First push the seat and cover together to the right, then lift them up.

Winter use

You can use your toilet as normal in cold weather as long as the toilet is situated in a heated location. If this is not the case and there is a risk of frost, we advise not to use your toilet. Make sure you completely empty the waste-holding tank.

Preparing waste-holding tank



1

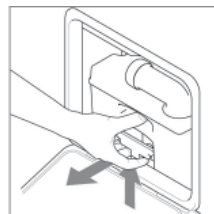

2



3



4



5



6



7



8



9

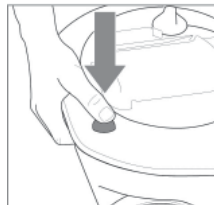

10



11

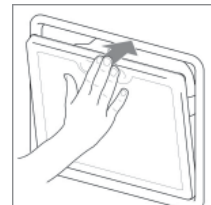

12

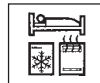

Preparing Electric Ventilator (if applicable)

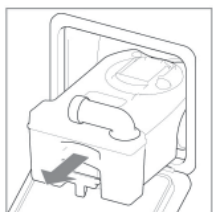

13

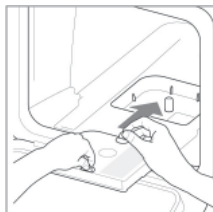

14

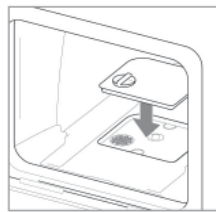

15

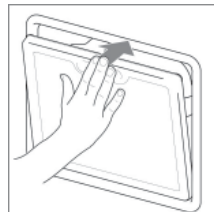

16

Emptying waste-holding tank

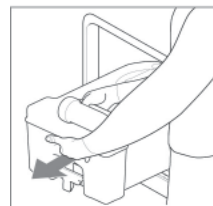

17

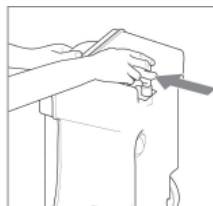

18

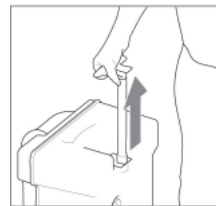

19



20



21



22



23

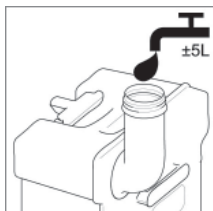

24

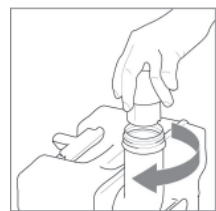

25

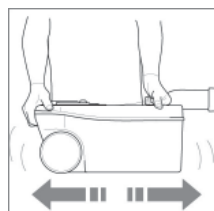

26



27



28



EQUIPMENT DETAILS

STATUS TV ANTENNA

OPERATING THE SYSTEM

Travelling

When positioning the Antenna Dome please allow for the following:-

DO NOT TRAVEL:-

- With the Antenna raised
- With the Antenna set for vertical signals

To reduce the possibility of damage when travelling, have the antenna pointing towards the rear of your caravan/motor home.

Operating

1. Loosen the Mast Locking Collar and raise the antenna.
2. Determine whether the TV transmissions are horizontal or vertical and position accordingly.
3. Switch On the Amplifier and the LED will illuminate and check the gain is set to MIN by rotating the button anti-clockwise.
4. Rotate the antenna.

RED - Poor signal - keep turning.

YELLOW - getting better - slow down.

GREEN - Signals located, ready to GO.

5. If there's no GREEN increase the Gain and repeat the 360 degree rotation.
6. Once the transmitter has been located increase the Gain to MAX.

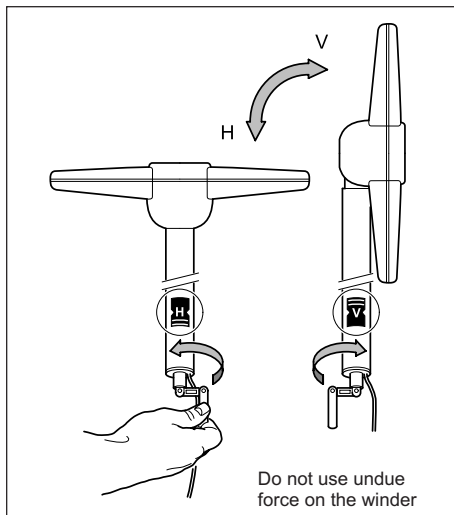

7. Turn on your television set and tune in. This will be necessary at all new locations.
8. Secure the Antenna by hand tightening the Mast Locking Collar.

IMPORTANT

You may detect more than one transmitter. Choose the position that gives you the most channels when tuning in your TV.

In poor signal areas the LED may only glow YELLOW.

In strong signal areas you may need to reduce the gain by rotating the Control anti-clockwise.

Removing the Antenna

A permanently fitted Status can be easily removed leaving only the Mounting Foot and rubber gaiter.

1. Unplug the antenna lead from the Amplifier.
2. Loosen the Mast Locking Collar and lift off whilst feeding out the mast, coaxial cable and plug.
3. Push the Blanking Cap supplied into place.

IMPORTANT - The Blanking Cap is a temporary seal and is not recommended for long term use.

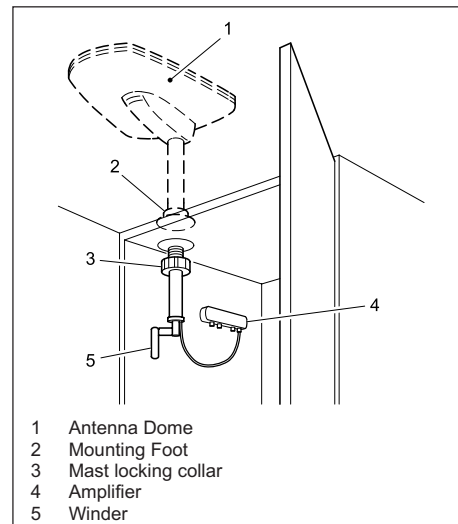

EQUIPMENT DETAILS



Signal	Symptom	Action
Very Poor	No picture or sound, TV freezing, severe pixilation, break up and picture drop out	Check the amplifier gain is set to maximum (rotate clockwise). Check antenna alignment which must be directed at the transmitter. Ensure the antennas polarity is correct, whether horizontal or vertical. Bypass the amplifier by following "Short Hook-Up Test 1"
Poor	Moderate pixilation and sound distortion	
Medium	Minor pixilation will not receive all channels	
Good	Stable picture, good sound quality will receive all channels	N/A
Strong	Possible pixilation, picture break up and drop out.	Reduce the amplifier gain (rotate anti-clockwise). Rotate antenna <i>AWAY</i> from the transmitter.
Very Strong	No picture or sound, TV freezing, severe pixilation, break up and picture drop out.	Rotate antenna <i>AWAY</i> from transmitter. Switch 'OFF' the amplifier and turn the gain control to maximum (rotate clockwise).
After performing any of the 'Actions' above you must re-tune your TV		

Guarantee

The Status Antenna has a return to base guarantee against defective parts and workmanship for two years or a period determined by the vehicle manufacturer. This does not include any malfunction resulting from improper use, incorrect installation, accidental or malicious damage. To support your guarantee claim a dated Proof of Purchase will be required.

This does not affect your statutory rights. Any queries concerning warranty please contact ourselves.

Fault Finding

The following are some of the key areas we suggest you check which generally solve the most common problems encountered with the operation of the Status antenna.

Coaxial Connections

It is critical that all connections in the system are fitted correctly and only quality plugs have been used.

Coaxial Cable

Sharp bends, kinks and hot surfaces can easily damage coaxial cable and should be avoided. Coaxial cable, if placed in close proximity to electrical cables, transformers or other pieces of electrical equipment, may pick up electrical interference causing picture quality to deteriorate, especially in poor reception areas. Excess cable should be removed and NOT coiled as this may cause picture distortion. An inspection of the routing of the cable is highly recommended to ensure all is correct.

Gain Control

In normal use the button should be rotated clockwise for maximum. In strong signal areas the amplification may need to be reduced. To reduce amplification rotate the button anti-clockwise until picture quality improves. The button rotates through 270 degrees from MAX to MIN



EQUIPMENT DETAILS

LED Light

Should the LED on the Amplifier not light, firstly check there is power to the unit. Secondly check the polarity is correct. Otherwise contact ourselves for further assistance.

Short Hook Up - Test 1

This test isolates the wiring from the Amplifier through to your TV/Radio points.

Unplug the coaxial plugs from the 'TV' sockets of the Amplifier and using your TV fly lead with Converter 1 supplied. Connect your TV to the Amplifier.

Please ensure the Antenna Dome is plugged directly into the 'ANT-IN' socket of the Amplifier and switch on. Tune in your TV for the strongest signal.

If the picture quality improves the fault lies with the wiring of the system between the Amplifier and the TV outlet socket.

Short Hook Up - Test 2

This test isolates the Amplifier by connecting your TV direct to the Antenna.

Unplug the Antenna from the Amplifier and connector Connector 2 supplied to the plug on the cable end. Using your TV flylead connect the antenna directly to your TV. Tune in your TV for the strongest signal.

If the picture quality improves the fault lies with the Vision Plus Amplifier.

Antenna Dome Co-axial Cable

Check the routing of the coaxial cable from the Antenna Dome to the Amplifier. Check to ensure there are no kinks or trapped cable or if there are loops of surplus cable which could be affecting performance.

Customer Help Line

Should you still be experiencing difficulties and require assistance, please do not hesitate to contact us at the address below.

MAINTENANCE

Gaiter

We suggest you periodically check the gaiter for any signs of damage or for wear.

If the rubber is caught by overhead obstructions it may rip or tear which would allow water to work its way into the fabric of the roof.

Over an extended period of time the gaiter will wear at the contact area with the mast. Should the gaiter begin to fail the signs will be small amounts of water dripping down the outside of the mast, however, the design of the Gaiter and Mounting Foot ensures that water cannot work its way into the fabric of the roof. Should this problem occur contact ourselves for a replacement unit.

Spares & Repairs

Should you require any parts for replacements or repair please log on to www.gradeuk.co.uk or contact ourselves on 0115 986 7151.

Vision Plus

8 Finch Close

Lenton Lane

Nottingham

NG7 2NN

0115 986 7151

info@visionplus.co.uk

www.visionplus.co.uk



PROJECT 2000 STEP

Manual Operation (Cassini Range)

Pull the step fully out once the vehicle is parked.

Prior to departure, push the step fully home. If the step is extended and the ignition is switched on an audible warning will sound. It can only be cancelled by pushing the step fully home.

Electrical Operation (Roadstar Range)

The step is operated by a switch inside the vehicle footwell. Hold the switch in the OUT position to extend the step.

To retract the step, hold the switch in the IN position. The step will automatically retract when the ignition is switched on.

CAUTION: Damage caused while the vehicle is in motion is not covered under the manufacturer's warranty. Be aware of low ground clearance and driving at high speed over rough ground.

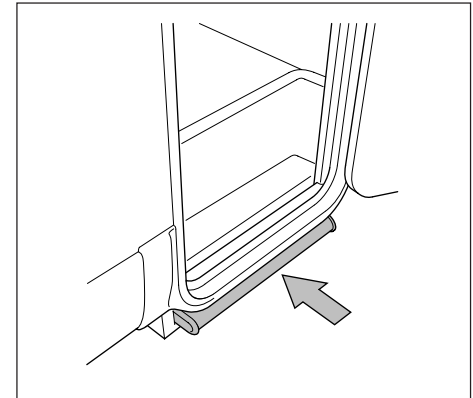
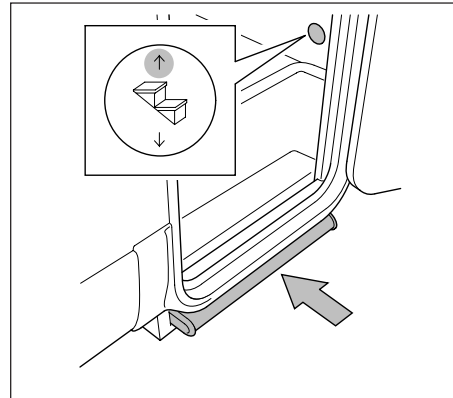
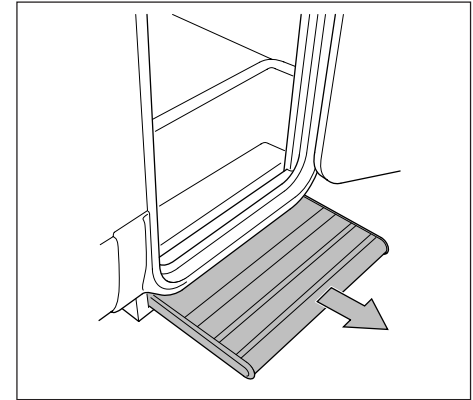
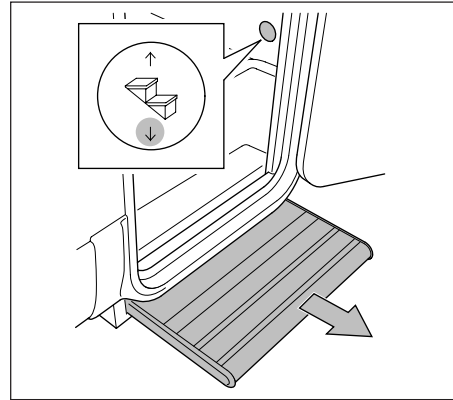



EQUIPMENT DETAILS

THULE AWNING

Note: Standard fitment is model specific.

In order not to damage the vehicle wall, never roll the awning out for more than 0,5 metre without getting the support arms out and ensure the vehicle is parked on level ground. Check regularly whether the adapters are well fixed to the vehicle.

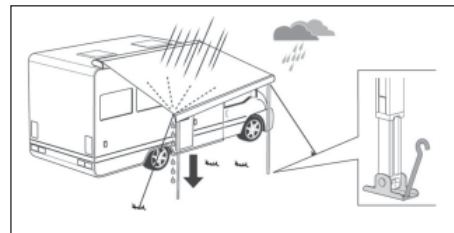
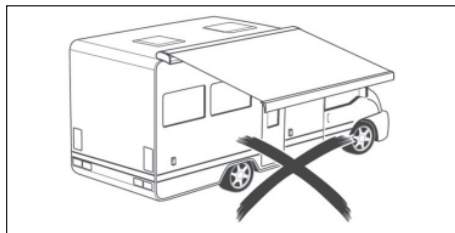
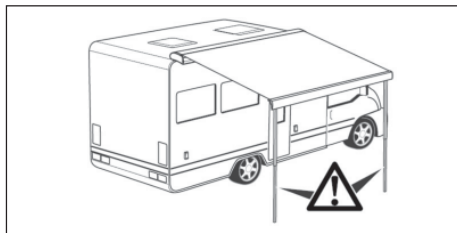
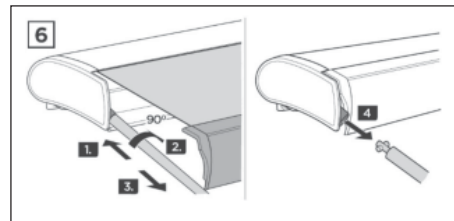
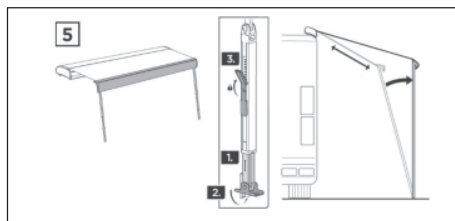
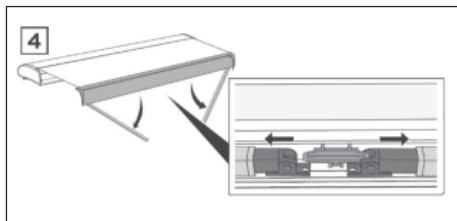
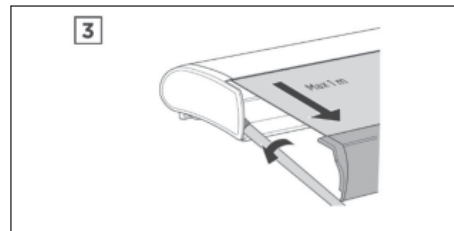
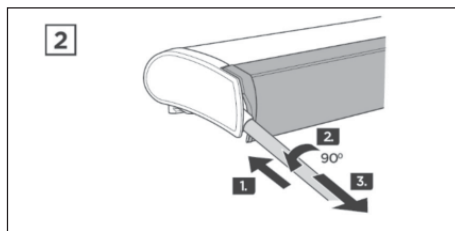
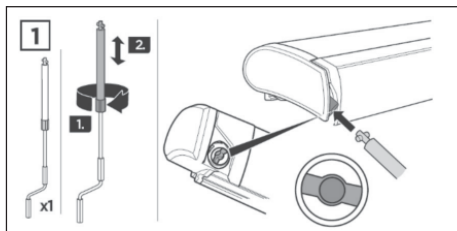



Swivel Seat

To turn the swivel, locate the handle located at the front of the seat. Pull the handle upwards and swivel the seat to the desired angle. Before driving off, make sure the seat is locked securely into the forward facing position.

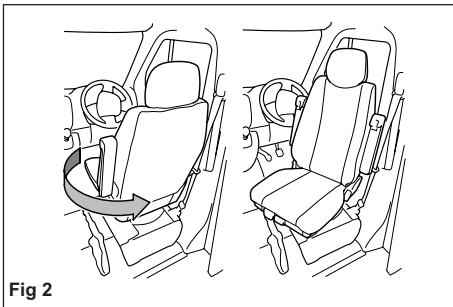
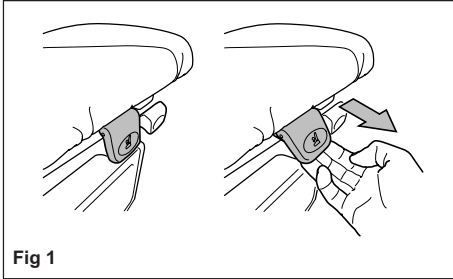

Day Time Table (TI)

- The table is stored under the rear bed frame. Lift the bed, the table is slotted into the frame and held in position using press stud straps. Release the straps and slide the table out (Fig 3).

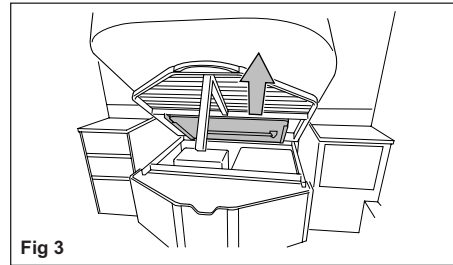

- The table is mounted in the second row passenger seating area. Hook the table onto the rail under the window and lock in position by sliding the two catches into position (Fig 4).

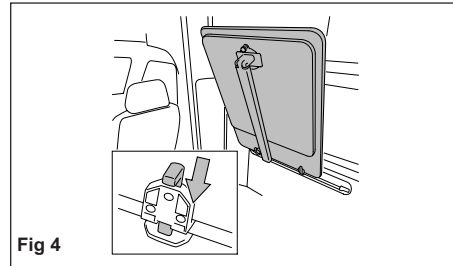

- Release the leg and lock into the down position and lower the table (Fig 5).

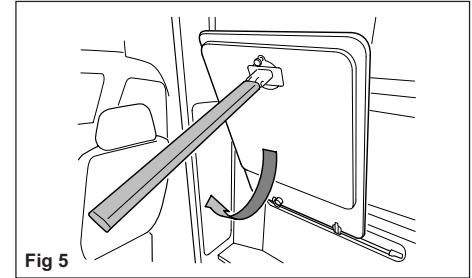

- The swing out leaf is released by pulling down the knob underneath the table and rotating to the desired position (Fig 6).

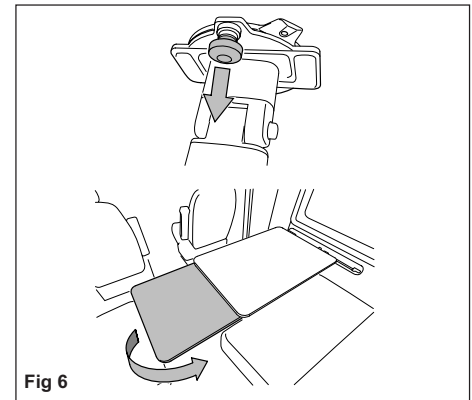



EQUIPMENT DETAILS

Day Time Table (EB)

- The table is stored in the garage area at the rear of the vehicle. It is released by turning the three turnbuckles.

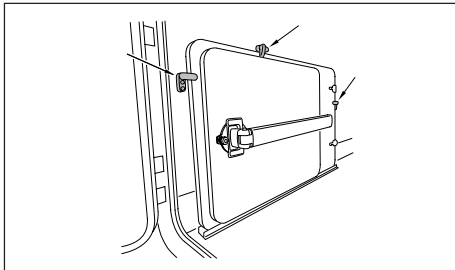

- The table is mounted in the second row passenger seating area. Hook the table onto the rail under the window and lock in position by sliding the two catches into position (Fig 7).

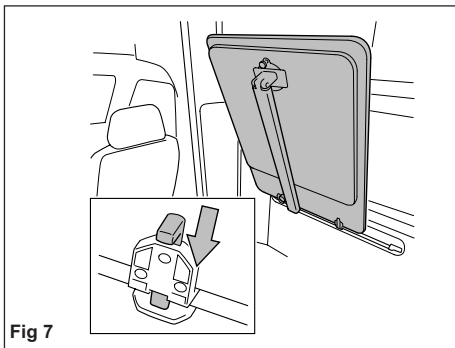

Fig 7

- Release the leg and lock into the down position and lower the table (Fig 8).

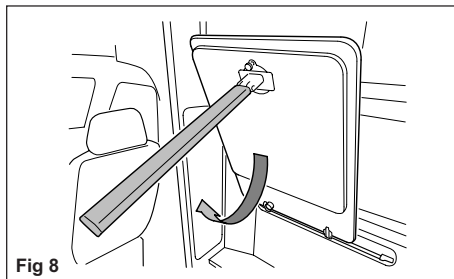

Fig 8

- The swing out leaf is released by pulling down the knob underneath the table and rotating to the desired position (Fig 9).

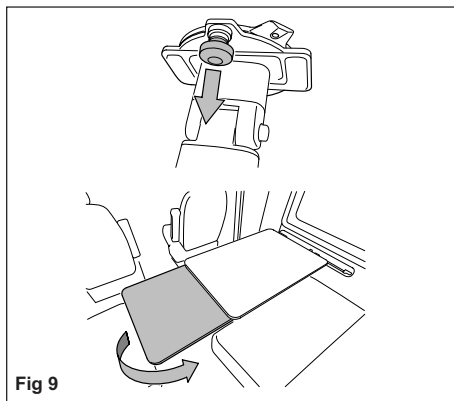

Fig 9

Day Time Table (EL)

- The freestanding table is stored in the wardrobe. (Fig 10). Release the turnbuckle and remove the table.

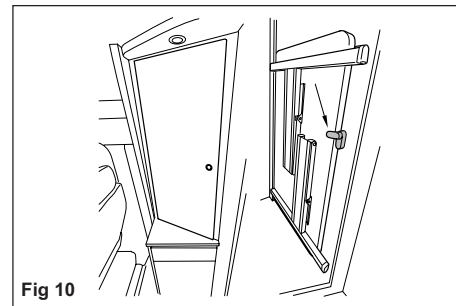

Fig 10

- Open out the legs ensuring they lock into position (Fig 11).

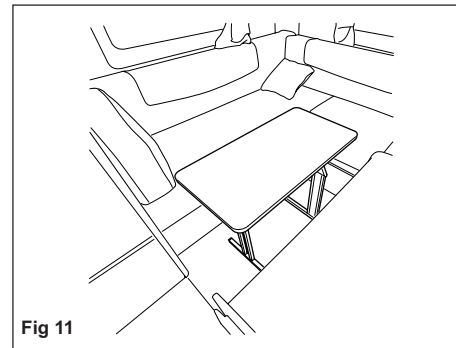

Fig 11



Preparing the vehicle for night time use

TI has fixed rear bed. EB has two rear permanent singles that are converted to a double. EL has two rear side seats that are converted into a double. TI and EB have a bed at the front, EL does not.

TI and EB front beds

Locate the slide underneath the second row passenger seats and extend fully (Fig 12).

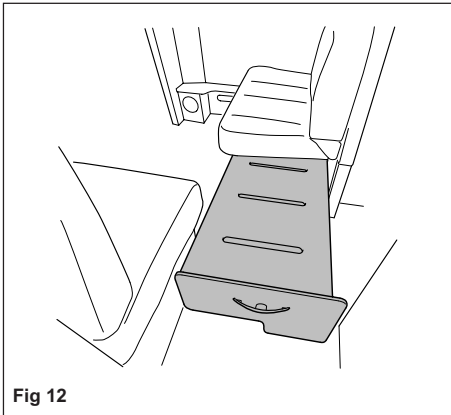

Locate the slide out extension underneath the side seat and extend it fully (Fig 13).

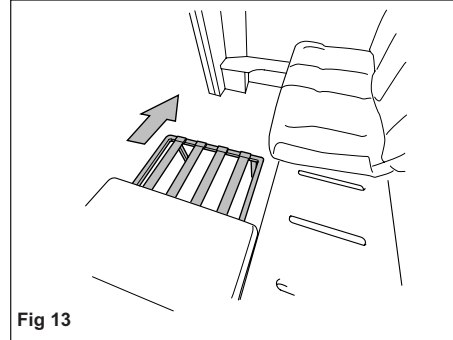

Slot the daytime table into place as shown (Fig 14).

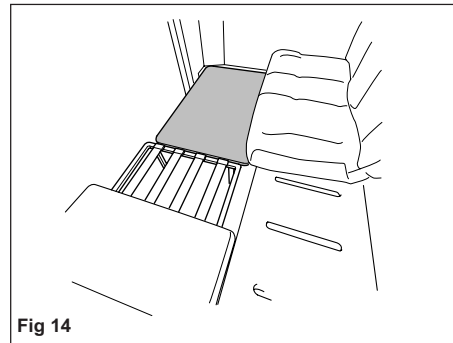

Slide the side seat cushions down and then place the infill cushions as shown (Fig 15).

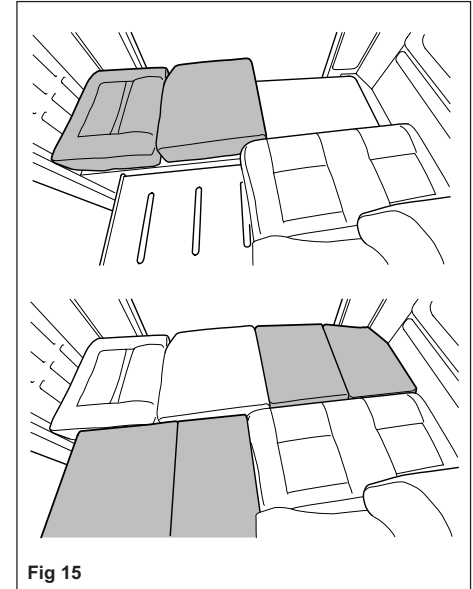



EQUIPMENT DETAILS

EB rear bed

The rear single beds can be converted to a double bed by locating the slide out section between them and extending it fully (Fig 16).

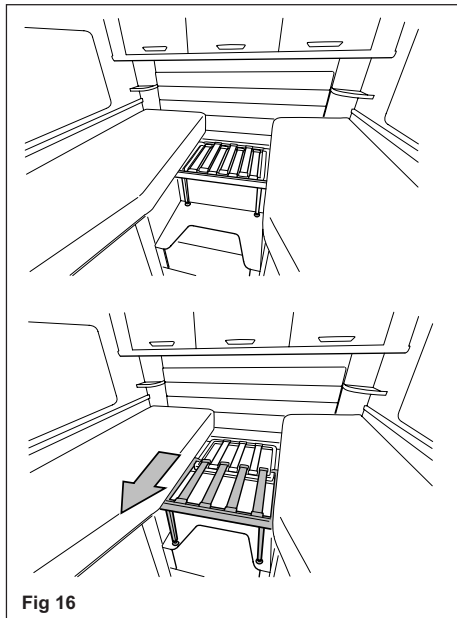

Slide the centre cushion down and place the infill cushion as shown (Fig 17).

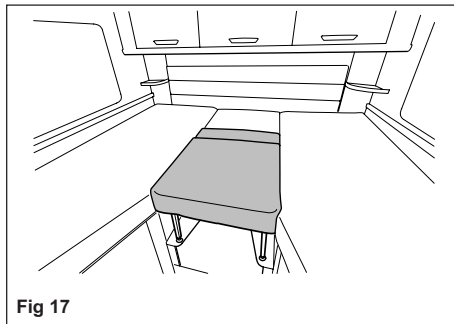

EL rear bed

Locate the slide out sections on both sides and pull them into position across the gap as shown (Fig 18).

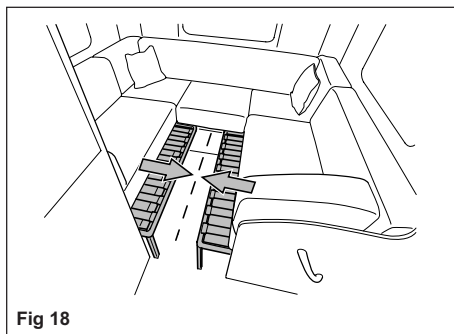

Remove the armrest cushions and store safely, then place the backrest cushions into the gap as shown (Fig. 19).

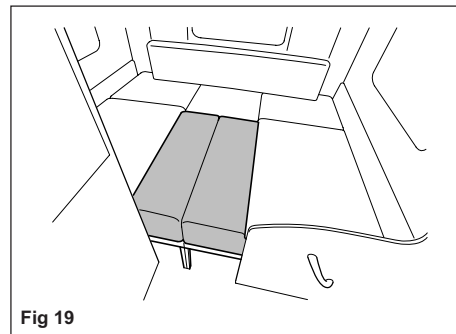



Reversing camera

The vehicle is equipped with a reversing camera located at high level at the rear of the vehicle as shown (Fig 1). It is activated as soon as reverse gear is engaged. The rear view mirror will display the view from the camera (Fig 2). For additional functions refer to the equipment manufacturers manual.

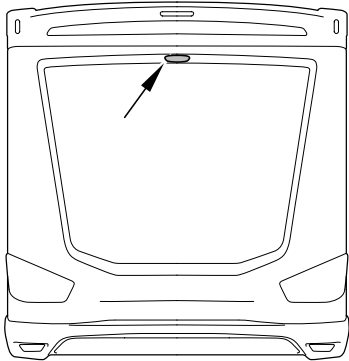

Fig 1

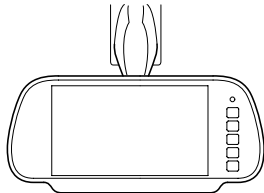

Fig 2



CONDENSATION

How to overcome condensation

Condensation occurs when the humidity inside the Motorhome exceeds 60% and ventilation is not sufficient.

Help yourself tips

- (a) Do not wash crockery last thing at night as it creates more moisture in the air.
- (b) Do not boil water last thing at night and empty all water from kettles, etc.
- (d) Keep temperature at night to a minimum (hot air contains water vapour) .
- (e) Increase ventilation to above normal in inclement or very wet weather.

Note: You cannot expect to eliminate condensation completely but following these hints will help towards a more comfortable environment.

Maintenance

Concerning gas and electric installations, only authorised experts are allowed to carry out maintenance and repair works. It is recommended to contact an authorised service centre. According to the valid regulations 6607 of DVGW, the gas installation as well as the flue outlets are to be checked every two years by an expert.

- 1) **Badges.** The upkeep of resin coated badges is simple, use soap and water only to clean them. Under no

circumstances should abrasive cleaners or solvent based solutions be used on them.

- 2) **Work Surfaces.** Laminated work surfaces are fitted to all furniture units. Whilst these are hard wearing, hot pans should not be placed directly on these surfaces since damage could result.
- 3) **Furniture.** Furniture should be cleaned with a proprietary furniture polish periodically. Any water marks that may occur on the hardwood edging of the furniture units should be removed by use of fine grade wire wool and furniture wax. Heavy stains may need to be sanded out and the edging re-polished.
- 4) **Soft Furnishings.** Seats, cushions and other soft furnishings should be cleaned with a proprietary fabric cleaner.
- 5) **Upholstery Cleaning.** Your upholstery should be brushed or vacuum cleaned regularly. Fabrics should be wiped every six to eight weeks with a lint free cloth and fabric cleaning fluid. Velour materials should be dry cleaned at regular intervals.
- 6) **PVC Window.** The PVC window may appear cloudy due to temperature changes and weather conditions. To avoid this and the build-up of mildew, clean with washing up liquid and apply gentle heat.
- 7) **Exterior Paintwork and Fibreglass.** Exterior paintwork should be regularly washed and polished with a non-abrasive

car wax. In the event of the bodywork blooming, the depth of shine can be restored by use of a mild 'T'-Cut abrasive cutting paste, followed by application of a wax polish.

- 8) **Maintenance.** Like any other pieces of equipment, your appliances will need regular servicing and cleaning as directed in the manufacturer's handbooks.
- 9) **Gas Flexible Rubber Hoses.** All gas flexible rubber hoses should be changed annually and must be secured at each end with jubilee clips. When removed they must be replaced with the approved type. **IMPORTANT: ALL FLEXIBLE HOSES MUST BE REPLACED ANNUALLY WITH NEW HOSE TO BRITISH STANDARD 3212/1.**
- 10) **Gas Installation. IMPORTANT:** Gas installations must be inspected annually by qualified personnel. If in doubt contact your local dealer. Modifications should not take place unless carried out by qualified tradesmen.
- 11) **Seat Restraints. IMPORTANT:** SEAT RESTRAINT MOUNTINGS SHOULD BE CHECKED FOR TIGHTNESS ANNUALLY AND RETIGHTENED IF NECESSARY TO A TORQUE SETTING OF 24 NEWTON METRES. IN THE EVENT OF ANY IMPACT OF 25 MPH OR OVER IN WHICH SEATBELTS HAVE BEEN WORN, THEY MUST BE REPLACED BEFORE THE VEHICLE IS USED AGAIN.



MOTORHOME CARE

- 12) **Servicing** of the automotive aspects of your motorhome is best carried out by a commercial vehicle service centre who would have a better understanding of your vehicle and should have any specialist tools that are necessary.

IMPORTANT: THE DASHBOARD FRESH AIR VENTILATORS SHOULD BE OPEN WHILST THE VEHICLE IS BEING USED. THE ROOF VENTILATORS ALSO CONTRIBUTE TO THE OBLIGATORY FIXED UPPER VENTILATION: THESE SHOULD NOT BE BLOCKED NOR THE AIRFLOW INHIBITED IN ANYWAY.

- 13) **Gas Vents.** All flue installations should be inspected at least once a year throughout their length for integrity of attachment, both to appliance and cowl and for perforation due to damage or corrosion. Flues should be replaced if any sign of damage or perforation is found. It should be ensured that the replacement is of an approved type conforming to the recommendations of BS 5440-1.

IMPORTANT: BLOCKING OF VENTS AND FLUES IS EXTREMELY HAZARDOUS AND SHOULD BE AVOIDED AT ALL TIMES.

- 14) **Tyre foam and inflator** is located under the front passenger seat. For operating instructions please refer to the base vehicle manual.
- 15) **Batteries.** Battery terminals and connectors should be firmly connected. Battery surfaces should be free of moisture and dirt. Cell tops must be fully tightened if appropriate. When removing a battery always remove the negative wire first. On reconnection the negative should be connected last. Switch off all lamps and appliances before disconnecting the battery.
- 16) **Exterior Cleaning** should NOT be conducted by way of a hose pipe or power wash device given the vehicle's exterior being vented.
- 17) **Shower.** There is a rubberised base panel in the bottom of the shower compartment. It can be lifted out in order to clean the shower floor as shown below.

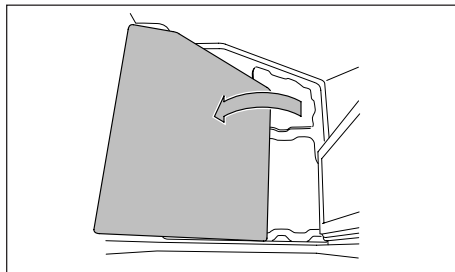

SAFETY PRECAUTIONS

General

- 1) In the interests of safety, replacement parts for an appliance should conform to the appliance manufacturer's specification and should be fitted by them or their authorised agent.
- 2) NEVER use portable heating equipment, other than electric heaters that are not of the direct radiant type, as it is a fire and asphyxiation hazard.
- 3) NEVER allow modification of electrical or LPG systems or appliances except by qualified tradesmen.
- 4) The water heater fitted to this vehicle is of the "room sealed" type, any replacement should be the same ie., "room sealed".
- 5) Turn off all gas equipment and cylinders/tanks and any other heating appliances before travelling, except heaters which are intended to be used while the vehicle is in motion.
- 6) **IMPORTANT:** Heaters intended for use while the vehicle is in motion MUST be turned OFF before refuelling the vehicle or its gas cylinders/tanks.
- 7) Make reference to the Base Vehicle Handbook for matters relevant to the Motorhome as a road vehicle.



- 8) Ventilation openings are located below all the gas appliances, and in the base of the gas locker. These openings should be regularly checked and any mesh covering them cleaned with a stiff brush to prevent any risk of them becoming blocked. Likewise, upper ventilation openings also must be kept free of debris.

IMPORTANT: HEAVY ITEMS MUST NOT BE STORED IN ANY OVERHEAD LOCKER OR CUPBOARDS, OR IN ANY STORAGE AREA FROM WHICH THEY COULD COME FREE AND CAUSE INJURY TO THE OCCUPANTS OF THE VEHICLE. ENSURE ALL CUPBOARDS ARE SECURELY FASTENED BEFORE MOVING OFF.

AEROSOLS AND HIGHLY FLAMMABLE MATERIALS MUST NOT BE STORED IN ANY COMPARTMENT BEHIND, OR ADJACENT TO, ANY HEATER OR HEAT SOURCE.

THE TABLES AND LEGS MUST BE STORED WHEN THE VEHICLE IS IN MOTION.

VENTILATION

Location of openings & cleaning

- 1) Do not obstruct ventilation.
- 2) General. Fixed ventilation is a statutory requirement in all motorhomes that are fitted with gas burning appliances. These ventilation apertures are positioned both high and low level.
- 3) Low Level Ventilation. Under each appliance is a fixed ventilation aperture, of a size commensurate with the rating of the appliance itself. It is either gauze covered or incorporates a fixed plastic vent.

Fresh air circulation should be allowed below the Motorhome when appliances are in use and when flues terminate below the floor to allow free evacuation of the products of combustion. At least three sides of the underfloor space should always be kept open and unobstructed especially by snow. Do not make any additional openings in the floor.

Under no circumstances must these vents be blocked or obstructed.

- 4) High Level Ventilation. High level ventilation is afforded through the roof canopy when used. The ventilation area relates to the rating of the appliances in

the vehicle. Vents must not be covered with any objects that may limit or affect the ventilation requirements.

- 5) Maintenance. Under no circumstances should any fixed ventilation aperture be blocked, covered either partially or fully or be modified in any manner whatsoever. They should be checked at least annually for damage or blockage and rectified accordingly.

SAFETY PRECAUTIONS

GAS APPLIANCES AND FITTINGS

TURN OFF GAS APPLIANCES, EXCEPT THOSE HEATING APPLIANCES DESIGNED TO FUNCTION WHILE THE VEHICLE IS IN MOTION.

- 1) Personnel. Ensure that you know how to operate the equipment - and never allow anyone other than a qualified person to connect or disconnect appliances and regulators.
- 2) Cylinders. Cylinders must be sited away from any heat source, in a well ventilated place and must stand in a stable upright position.
- 3) Regulators. Your Motorhome is fitted with a regulator as standard equipment. The gas regulator has a working pressure of 30mbar and is suitable for both propane



MOTORHOME CARE

and butane liquefied petroleum gas.

There are dedicated hoses available for different types of gas/bottle. They are also available for camping gas and other mainland Europe LPG suppliers. Please contact your retailer who will have a stock of these hoses.

Note: Regulator valves should always be in the 'OFF' position when towing.

WARNING: Some industrial LPG appliances operate at high pressure and require a 'high pressure' regulator. This often has an adjusting handle on it. NEVER use such a regulator on a Motorhome.

Propane and Butane gas regulators are not interchangeable.

Cylinders and regulators are also not interchangeable between different makes of gas cylinder.

For propane and butane cylinders always ensure that the mating parts are clean, free from dirt and undamaged, and, in the case of butane regulators, check that the washer is in place on the spigot of the connector and is in good condition.

- 4) Awnings. Awnings should be fitted so that any flue discharge into them does not constitute a hazard.

There is no danger of pollution of an enclosed awning space by the LPG exhaust from the refrigerator venting into it.

WARNING: Space heaters may produce sufficient exhaust gases to pollute the awning space if it is totally enclosed (from a general comfort, smell, and hygiene point of view). In the extreme case, there could be a build up of carbon dioxide to a dangerous level.

Note: Motorhome owners are **strongly advised** against placing an awning on the same side as the Space Heater Exhaust, as this will prevent fresh air circulation into the awning.

FIRE

IN CASE OF FIRE: Get everybody out.

- 1) Switch off engine.
- 2) Switch off fuel/gas/electricity.
- 3) Disconnect mains electrical supply.
- 4) Raise the alarm and call the fire brigade.
- 5) Tackle the fire if it is safe to do so.
- 6) As soon as possible, remove cylinders adjacent to the fire to a safe place in order to gain access to the seat of the fire.

FIRE PRECAUTIONS

- 1) Children should not be left alone in the Motorhome.
- 2) Keep combustible materials clear of all heating and cooking appliances.
- 3) Provide one dry powder fire extinguisher of an approved type or complying with ISO 7165 of at least 1 kg capacity by the main exit door, and a fire blanket next to the cooker. Familiarise yourself with the instructions on your fire extinguisher and the local fire precaution arrangements.
- 4) Means of Escape - Make sure you know the location and operation of emergency exits, keep all escape routes clear.



ROADSTAR/CASSINI WARRANTY

To protect you and your motorhome never leave the registration documents in the vehicle. For security purposes keep it in a safe place.

Your Roadstar/Cassini Motorhome is supplied to you with a three year warranty that is valid from the date of purchase, except otherwise stated and is conditional on annual servicing being carried out.

The base vehicle warranty is provided by Renault and is against any failures in the vehicle caused by any manufacturing defects that may have occurred when your vehicle was built. The warranty is backed by a standard three year unlimited mileage warranty and replacement parts for major assemblies are backed by a standard two year unlimited mileage warranty. The warranty starts from the date of registration or, if earlier, the date of sale.

Should a fault arise contact should be made with your local Renault dealership.

What does the warranty cover?

Renault will cover any defects in material or workmanship that occur as a result of the vehicle manufacturing process. Whilst glass is not covered, warranty would apply in the case of a stress fracture. In this way Renault will accept responsibility for those items that are theirs but cannot cover any non-approved modifications, accessories or bodywork applied after the vehicle manufacture.

What is not covered?

Renault will not cover problems that arise from

- A failure to follow instructions contained in the vehicles operating manual or maintenance booklets, or from your Authorised Renault dealer, Garage or repairer
- A failure to have the vehicle maintained and serviced correctly and at the required intervals as set out in the maintenance booklet
- Incorrect repairs by an unauthorised garage
- The fitting of non-approved parts, additional equipment and bodywork, or other unauthorised vehicle modifications (your Renault Dealer will be happy to advise)

- Using and driving the vehicle outside the instructions outlined in the driver's handbook
- Damage caused by excessive speed
- Not following advice provided by the vehicles information system or dashboard warning lights
- Exceeding gross vehicle weights, axle loads and payload capacity
- Normal wear and tear on parts, including friction and consumable items as oils and lubricants, filters, brake pads, clutch materials, wiper blades, tyres, some exhaust components and shock absorbers. This list is not exhaustive
- External events including environmental issues such as storms and floods, accident damage, salt corrosion, civil unrest or vandalism.



WARRANTY

How do I get a warranty issue resolved?

- Simply contact a Renault Authorised repairer. This should be done as soon as possible (and within one month) of the defect becoming apparent
- All warranty work must be carried out by a Renault Authorised Repairer, who in turn will use only Renault Genuine Parts. Payment for the work is always made direct from Renault to the Authorised repairer.
- The full service history of your vehicle must be made available to the Authorised Repairer and you must allow them to fully inspect your vehicle. This may take time, including the possibility of more than one visit to the workshop.
- Defective parts from your vehicle become the property of Renault.

Can my warranty be invalidated?

- Modifications affecting the basic integrity of the vehicle, especially to the chassis or electronic systems.
- Tampering of the odometer. The only people who can do this work are trained Renault technician, who have to follow precise legal guidelines
- Write-offs. Any vehicle that been declared a write-off may not be eligible for warranty if the claim is attributed to the accident damage.

Lunar Caravans will cover the total cost of any labour of parts free of charge providing there is a full service history and reserve the right to examine the vehicle prior to commencement of any repairs and if necessary nominate a repairer.

Should any faults arise contact should be made with your dealer.

In the first 12 months the Motorhome warranty will cover any defect other than those specified in the exclusion below.

1. Misuse of any component
2. Cleaning and adjustment of assemblies
3. Routine maintenance items which form part of the annual servicing for the vehicle, including adjustment and lubrication of locks, the cleaning of the heater, fridge and rubber gas hoses.
4. Damage resulting from over-heating, freezing, fire or any accidents caused by the owner of a third party
5. Continued use after failure has become evident, thus exacerbating the problem
6. Using the vehicle other than for its intended purposes and for those vehicles which are let out for hire or rewards.

7. The cost of transporting or moving the vehicle by any means to or from a place of repair or consequential cost relating to transportation

8. Damage caused by modification.

In year 2 the following items are covered other than those specified in the exclusions below:

Water heater

Television

Driver and passenger and driver seats and bedding

Microwave

Alarm

Toilet

In year 3 the following items are covered other than those specified in the exclusions below:

Television

Electrical wiring



Exclusions

9. Misuse of any component
10. Cleaning and adjustment of assemblies
11. Routine maintenance items which form part of the annual servicing for the vehicle, including adjustment and lubrication of locks, the cleaning of the heater, fridge and rubber gas hoses.
12. Damage resulting from over-heating, freezing, fire or any accidents caused by the owner or a third party
13. Continued use after failure has become evident, thus exacerbating the problem
14. Using the vehicle other than for its intended purposes and for those vehicles which are let out for hire or rewards.
15. The cost of transporting or moving the vehicle by any means to or from a place of repair or consequential cost relating to transportation
16. Damage caused by modification





NOTES



CHANGE OF OWNERSHIP



If you sell your Motorhome or are the new owner, please notify us of the change of ownership by completing the change of ownership form on the next page and send it to:

Lunar Caravans Limited
After Sales Department
Sherdley Road
Lostock Hall
Preston
PR5 5JF

There is a £50 administration fee for the transfer of ownership. Cheques should be made payable to Lunar Caravans Limited and send to the above address along with the vehicle's service history.



CHANGE OF OWNERSHIP

NOTIFICATION OF CHANGE OF OWNERSHIP

PURCHASE DATE		PURCHASED FROM (DEALER NAME IF APPLICABLE)	
----------------------	--	---	--

MOTORHOME DETAILS

Model	
Vehicle Identification Number	

CURRENT OWNER

Name	
Address	
Post Code	
Telephone Number	
Date of Ownership	

NEW OWNER

Name	
Address	
Post Code	
Telephone Number	
Date of Purchase	

PLEASE FORWARD THIS FORM, WITH A COPY OF YOUR SALES RECEIPT TO:

Lunar Caravans Limited, After Sales Department, Sherdley Road, Lostock Hall, Preston, PR5 5JF.

From time to time our Marketing Department may use the information recorded on our database to inform customers of new products and updates. If you wish to opt out from this, please tick

ANNUAL HABITATION SERVICE RECORD



MOTORHOME MODEL _____ YEAR _____

CHASSIS (VIN) NUMBER _____

<p>1st INSPECTION</p> <p>DATE:</p> <p>DEALER'S STAMP</p> <p style="text-align: center;">We certify that an annual inspection has been carried out in accordance with the Service Checklist.</p>	<p>2nd INSPECTION</p> <p>DATE:</p> <p>DEALER'S STAMP</p> <p style="text-align: center;">We certify that an annual inspection has been carried out in accordance with the Service Checklist.</p>	<p>3rd INSPECTION</p> <p>DATE:</p> <p>DEALER'S STAMP</p> <p style="text-align: center;">We certify that an annual inspection has been carried out in accordance with the Service Checklist.</p>
<p>4th INSPECTION</p> <p>DATE:</p> <p>DEALER'S STAMP</p> <p style="text-align: center;">We certify that an annual inspection has been carried out in accordance with the Service Checklist.</p>	<p>5th INSPECTION</p> <p>DATE:</p> <p>DEALER'S STAMP</p> <p style="text-align: center;">We certify that an annual inspection has been carried out in accordance with the Service Checklist.</p>	<p>6th INSPECTION</p> <p>DATE:</p> <p>DEALER'S STAMP</p> <p style="text-align: center;">We certify that an annual inspection has been carried out in accordance with the Service Checklist.</p>



ANNUAL HABITATION SERVICE RECORD

MOTORHOME MODEL _____ YEAR _____

CHASSIS (VIN) NUMBER _____

<p>7th INSPECTION</p> <p>DATE:</p> <p>DEALER'S STAMP</p> <p>We certify that an annual inspection has been carried out in accordance with the Service Checklist.</p>	<p>8th INSPECTION</p> <p>DATE:</p> <p>DEALER'S STAMP</p> <p>We certify that an annual inspection has been carried out in accordance with the Service Checklist.</p>
<p>9th INSPECTION</p> <p>DATE:</p> <p>DEALER'S STAMP</p> <p>We certify that an annual inspection has been carried out in accordance with the Service Checklist.</p>	<p>10th INSPECTION</p> <p>DATE:</p> <p>DEALER'S STAMP</p> <p>We certify that an annual inspection has been carried out in accordance with the Service Checklist.</p>

A

Arrivals 3-1

B

Batteries 7-1

Boiler

Truma Combi 9-2

C

Carbon Monoxide Alarm 7-3

Codes of Conduct 3-1

Awnings & Tents 3-2

Camp Sites 3-1

Dogs and Pets 3-1

Fire Precautions 3-1

Noise 3-1

Parking 3-2

Use of Site Appliances 3-1

Vehicle Movement 3-1

Waste Disposal 3-1

Wild Camping 3-2

E

Electrical Systems 7-1

Electricity

Overseas Connection 8-18

F

Fire Extinguishers 7-1

Fire Safety 7-1

Children 7-1

Fuses 8-31

H

Hob

Thetford 3 Burner Hob 9-29

L

Loading of Weight 4-1

M

Microwave 9-31

O

Oven

Grill 9-21

Spinflow Combi Oven 9-27

P

Positioning the Motorhome 6-1

Power Control System 8-20

R

Refrigerator 9-11

S

Safety Precautions

Fire 10-4

Seat Belt Legislation 5-1

Security 1-1

Selecting a pitch 6-1

Services

Electricity 8-17

Gas 8-10

T

Toilet

Cassette Toilet C-260 CWE 9-32

V

Ventilation 7-1, 8-13, 10-3

Ventilation & Condensation 7-1

