

# CONTENTS

TOWING CODE



PREPARING FOR THE ROAD



ON THE ROAD



FIRE & SAFETY



SERVICES



ELECTRICS



FITTED EQUIPMENT



AL-KO CHASSIS & TYRES



GENERAL DATA



# INTRODUCTION

## INTRODUCTION

Lunar Caravans Ltd welcomes you as you join the ranks of owners of Venus Caravans. We hope you will enjoy your caravan and this handbook tells you how to look after it so that it may give you years of pleasure and enjoyment.

Remember that it is a vehicle and thus calls for a small amount of regular maintenance.

**You are requested to contact your dealer on all enquiries in order to ensure satisfaction. You will only experience delays if you bypass the normal channels.**

Your Venus Caravan has been European Commission Whole Vehicle Type approved via LuxControl and has also been inspected by the National Caravan Council (NCC) to ensure your new caravan is compliant and safe to use.

Your Venus caravan has been built and approved to EN1645 which applies to a large number of features such as:

- sizes of beds
- escape factor i.e. windows and exterior door
- materials
- design and construction

- insulation is grade 3 classified which is able to achieve an average temperature difference of 35 degrees centigrade between interior and exterior when the exterior is -15 degrees centigrade
- electrical equipment, both 12 volt and 230 volt
- chassis
- undergear
- drawbar
- jockey wheel
- wheels and tyres
- installation of gas
- ventilation
- awnings and channel
- fire notices
- handbook

Touring caravans are designated by their model year which runs from 1 September to 31 August. A new year model can only be registered by CRIS from 1st September onwards.

This caravan has been security marked and recorded under the Caravan Registration and Identifications Scheme that is organised by the Caravan Industry.

Your Touring Caravan Registration Document will include a 17 character V.I.N. (Vehicle Identification Number), which is also chemically etched on eye level windows.

To protect yourself and your touring caravan, never leave the Registration Document in the caravan. For security reasons keep it in a safe place.

*Disclaimer: The contents of this Handbook book are as accurate as possible at the time of going to print. Lunar Caravans reserve the right to alter materials and specifications without prior notice. Venus Caravans is a brand of Lunar Caravans Ltd.*



# TOWING CODE

Scope of Code .....	4
Caravan Terms .....	4
Weights .....	4
Towing Vehicle Terms .....	4
Measurement of Noseweight .....	6



# TOWING CODE

## THE CARAVAN TOWING CODE

### Industry Payload Standard for UK touring Caravans

This standard has been prepared by the National Caravan Council and formulated with input from Industry Experts. The standard applies to UK specification Touring Caravans and will apply for the NCC certification from 2011 onwards model year Touring Caravans.

For the 2012 model year the method of calculating the Mass in Running Order (MRO) and user payload figures are in line with European Vehicle Directives and provides for the requirements for European Whole Vehicle Type Approval EWVTA, 2007/46/EC (The Framework Directive) and the directives referenced therein.

## DEFINITIONS

### Maximum Technically Permissible Laden Mass (MTPLM)

The fully laden mass of the caravan in the manufacturer's standard specification which is stated in the manufacturer publications by the manufacturer for tow car matching. This mass takes into account the specific operating conditions including factors such as the strength of the materials, load capacity of the tyres etc, and can be found on a plate affixed to the caravan, usually near the entrance door.

Please note: The MTPLM is the maximum weight that the caravan can be loaded to, this mass must NOT be exceeded. However most models can have the MTPLM upgraded in capacity; this must be approved by Lunar Caravans Ltd via the dealership. Please contact your dealership for further details.

### Mass In Running Order (MIRO) or (MRO)

This is the weight of the caravan as it leaves our factory (inclusive of the electrical hook-up cable at 6kg and the winding handle at 1kg) plus the following:

8kg allowance for gas bottles.

9kg of water in the water heater.

2kg of water in the toilet holding tank as this is the maximum recommended by Thetford.

### User Payload (UP)

The difference between the MIRO and MTPLM (excluding potential MTPLM upgrade). The user payload allows for items common to all occupants, such as food, cutlery, pots, pans, clothing, footwear, bedding, sports equipment etc. The user payload also includes an allowance for the auxiliary battery.

The UP is calculated by the following formula:

$$10L + 10N + 50.$$

L is the body length of the caravan in meters.

N is the number of berths.

50 is for normal equipment carried in the caravan, a sample list is given below.

TV .....	3kg
Kettle .....	0.5kg
Bed linen .....	6kg
Crockery .....	5kg
Saucepans .....	3kg
Wastemaster .....	6kg
Aquaroll (empty) .....	5kg
Waste bin .....	1kg
Cutlery .....	2kg
Toilet fluid etc .....	2.5kg
Battery .....	16kg



## Optional Equipment Payload (OEP)

Items made available by the manufacturer over and above the standard specification for the caravan in addition to the user payload.

## Personal Effects Payload (PEP)

A mass specified for the items which a user can choose to carry in a caravan and which are not included as an essential habitation equipment or optional equipment.

Optional Item	Additional Weight
R/C Alarm/Awning Light .....	1 kg
AL-KO Secure wheel locks (per lock) ....	2 kg
AI-KO ATC Trailer Control .....	2 kg
Air Conditioning .....	30 kg

**Please note:** Any options fitted by retailer will reduce the overall payload available to the customer.

## REGULATORY AND SAFETY ADVICE

**WARNING:** UNDER NO CIRCUMSTANCES SHOULD THE MAXIMUM TECHNICALLY PERMISSIBLE LADEN MASS (MTPLM) BE EXCEEDED. PLEASE TAKE CARE TO ENSURE THAT YOU HAVE ALLOWED FOR MASSES OF ALL ITEMS YOU INTEND TO CARRY IN THE CARAVAN e.g. Optional equipment and personal effects such as clothing, food, pets, bicycles, sailboards, sports equipment etc.

THE MASS OF THE CARAVAN IN RUNNING ORDER (MIRO) CONTAINS PROVISION FOR THE MASSES OF LIQUIDS, GAS ETC. PART OF THIS PROVISION CAN ALSO BE UTILIZED AS ADDITIONAL PAYLOAD IF FOR EXAMPLE YOU WISH TO TRAVEL WITH NO GAS CYLINDERS.

## THE CARAVAN AND TOWING VEHICLE RATIO

This can be determined by calculation and is equal to:

$$\frac{\text{actual laden weight of caravan}}{\text{kerb weight of towing vehicle}} \times 100\%$$

THE **LAW** REQUIRES THAT CARAVANS & THEIR TOWING VEHICLES & THE LOADS THEY CARRY MUST BE IN SUCH A CONDITION THAT NO DANGER OR NUISANCE IS CAUSED.

(Regulation 100 of the Road and Vehicles [Construction and Use] Regulations 1986).

### IMPORTANT NOTICE:

Your caravan has been designed and manufactured for towing behind normal road cars. Additional care should be taken when towing with a 4x4 due to the 'off-road' nature of the suspension. Caravans are not suitable for towing behind commercial vehicles.

### POWER TO WEIGHT RATIO:

No hard and fast rules can be stated but, here is a general guide.

- (a) Conventional petrol engines with a capacity up to approximately 1500 cc should be adequate for towing a caravan weighing around 85% of the kerb weight of the towing vehicle.



## TOWING CODE

- (b) Above 1500 cc such engines should manage a caravan weighing up to 100% of the kerb weight of the towing vehicle and still give adequate performance.

**Note: The towing vehicle manufacturer's limit is, in some cases, less than the kerb weight.**

Vehicles with automatic transmission may need an oil cooler to be fitted or the SAE rating of the gearbox oil increased when towing. The advice of the vehicle manufacturer should be sought.

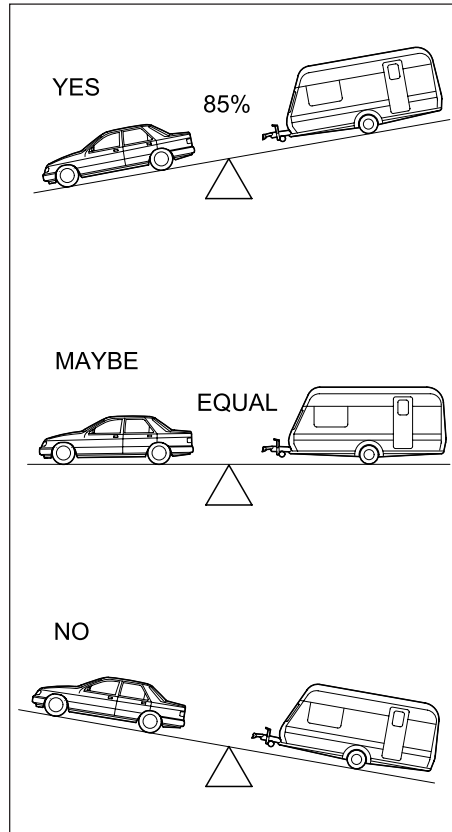

## MEASUREMENT OF NOSEWEIGHT

Towing noseweight should be a minimum of 50kg and heavier for twin axle models. This may be measured using a proprietary brand of noseweight indicator. Such equipment is obtainable at your Venus Caravan Dealer.

Another simple method is to use bathroom scales under the coupling head with a piece of wood fitted between the coupling head and the scales, of such length that the caravan floor is horizontal with the jockey wheel raised.

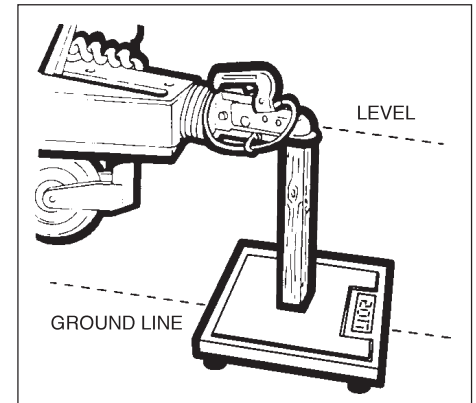



# PREPARING FOR THE ROAD

Checklist .....	8
Loading and Distribution .....	8
Stability .....	9
Pre-Tow Checklist .....	10
Stabiliser .....	11
Wheel Lock .....	13
Breakaway Cable .....	17
Tyres .....	18



# PREPARING FOR THE ROAD

## PRE-LOAD CHECKLIST

**Caution: Never enter the caravan without first lowering the four corner steadies with the brace provided.**

### CHECK THAT:

- loose articles are stowed securely. Do not stow tins, bottles or heavy items in overhead lockers prior to towing.
- all lockers and cupboard doors are closed and secured.
- all bunks are secure.
- all rooflights are closed and secured.
- main table is stored in its transit position.
- fridge is on 12v operation and door lock is set.
- all windows are fully closed and latched. Never tow with windows on nightsetting. Leave all curtains and blinds open to aid rear visibility.
- gas cylinders are correctly positioned, secured and turned off.
- battery is secure.
- wheelnuts for tightness.
- tyre pressures and condition of tyres.

## LOADING AND DISTRIBUTION OF WEIGHT IN THE CARAVAN

Do not exceed recommended maximum loading for your caravan.

1. Load heavy items low down near the floor and mainly over or in front of the axle(s).
2. Load evenly right to left.
3. Do not load items at the extreme rear since this can lead to instability due to the 'pendulum effect'.
4. Load remainder to give a suitable noseweight at the towing coupling.
5. Check noseweight. (Lunar Caravans are designed to be towed with a minimum noseweight of 50kg and heavier for twin axle models) (See page 4).

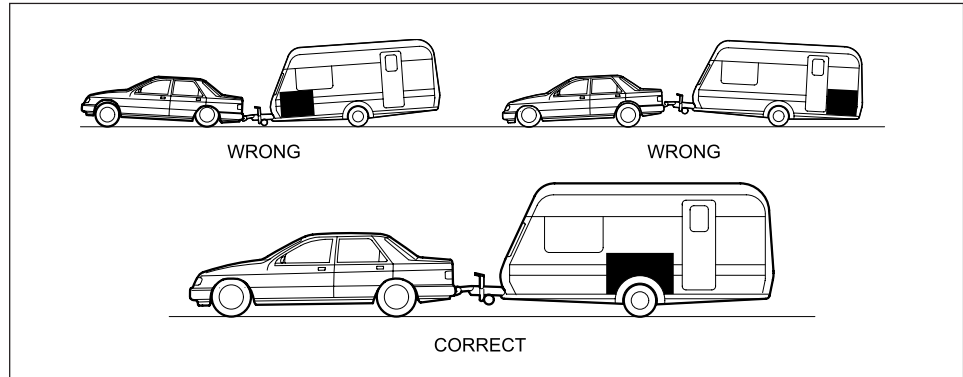
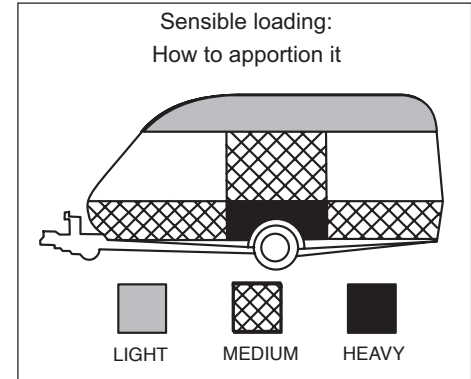

**Note: Do not load car boot heavily.**





## STABILITY

The most common causes of poor stability include:

- (a) Incorrect tyre pressures on car or caravan.
- (b) Worn springs or loose spring fixings on the towing vehicle.
- (c) Towing vehicle shock absorbers too soft.
- (d) Insufficient noseweight.
- (e) Nose of caravan is towing too high.
- (f) Incorrect loading

**Stabilisers.** There are many proprietary brands of stabiliser available. Your Lunar dealer will be pleased to advise you of the most suitable. They are an aid to stability and should not be considered as a cure for a stability problem.

**Note: It is expressly forbidden by the chassis manufacturer for holes to be drilled into the 'A' frame to accommodate a stabiliser bracket. A clamp must be used. Similarly, holes should not be drilled into the coupling head.**

## Towing vehicle's rear suspension

It is important that the towing vehicle's rear suspension is not deflected excessively by the noseweight on the tow ball. If it is excessive the steering and stability will be affected.

The greater the towing vehicle's tail overhang (the distance between the rear axle and the tow ball) the greater the effect the noseweight will have on the towing vehicle's rear suspension.

After trying out the caravan it may be found that stiffening of the rear suspension is necessary — but note that this may give the towing vehicle a firmer ride when not towing.

There are a number of suspension aids available and advice should be sought on which to use and how to fit.

It is important to ensure that the caravan is towed either level or slightly nose down.

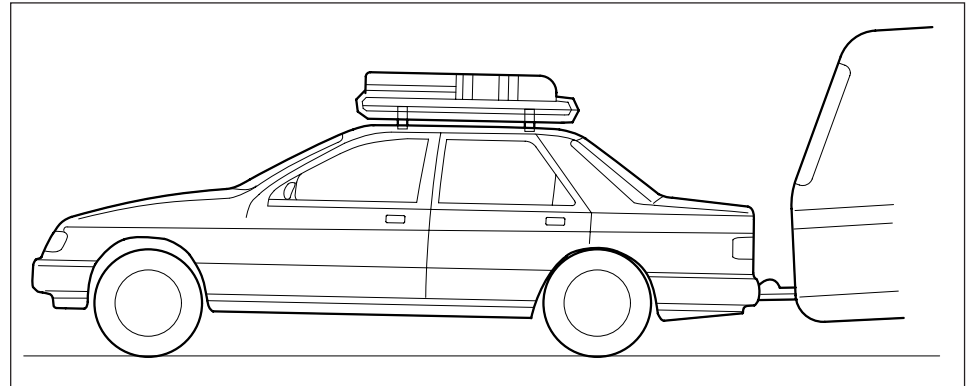

Illustration of excessive deflection of vehicle's rear suspension



## PREPARING FOR THE ROAD

### PRE-TOW CHECKLIST

1. Check that the hitch is securely coupled onto the towball and connect the breakaway cable. Your hitch height should be around 440mm (17") to the centre of the towball when the towing vehicle and caravan are coupled and laden.
2. The Jockey wheel should be raised and tightly clamped or removed completely if desired.
3. Corner steadies must be wound up fully.
4. Plug in the electrical connection to the car, keeping the cable clear of the road and check the operation of lights.
5. Release the handbrake. "Failure to ensure that the handbrake is completely off, can result in overheating of the brakes and failure of the bearings".
6. Check tyre pressure with cold tyres (see specification). Wheel bolt torque settings should be 88Nm (65lbs/ft) for steel wheels. Alloy wheels should be 115Nm (85lbs/ft).
7. Adjust the tyre pressures of your tow car to the manufacturers recommendations for full loads.
8. Engage the stabiliser, if fitted.
9. Fit towing mirrors to your car.

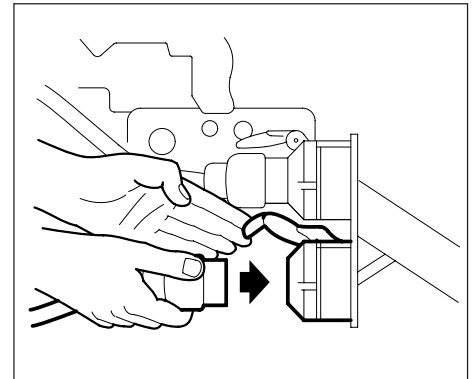
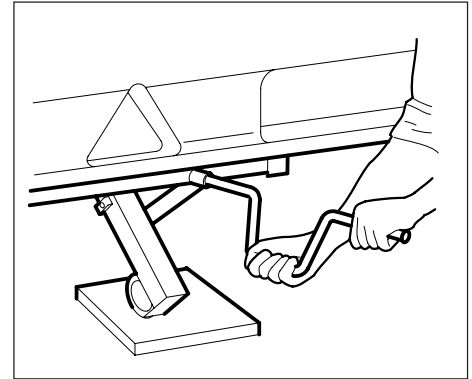
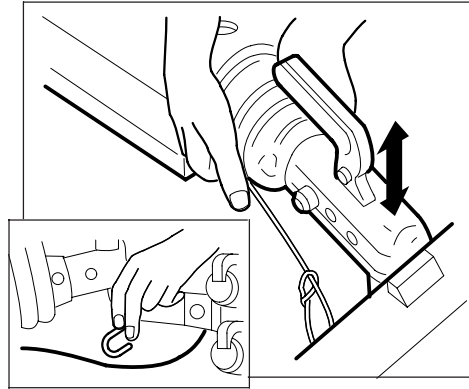



## AKS STABILISER (where fitted)

This model of stabiliser has 4 special friction pads, which suppress both snaking and pitching. It is essential that the tow ball is kept completely clean as contaminated pads will reduce its effectiveness.

### Operating instructions

- Using the coupling handle, put the AKS on to the towball. Push the black handle down and check the green indicator button is showing (Fig. 1).
- Press the red stabilising lever down. The AKS is now ready for the road (Fig. 2).

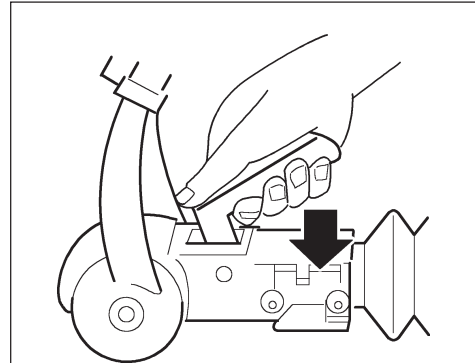

Fig. 1

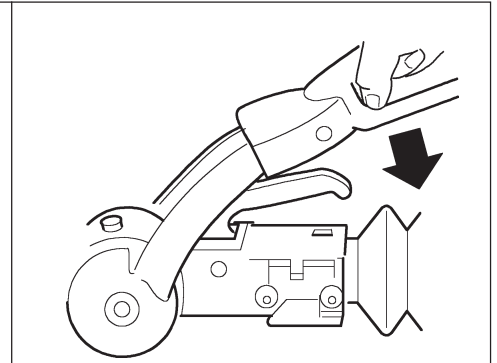

Fig. 2

### Safety indicators

If the green indicator is visible then you know you have correctly coupled your AKS to your towing vehicle (Fig. 3).

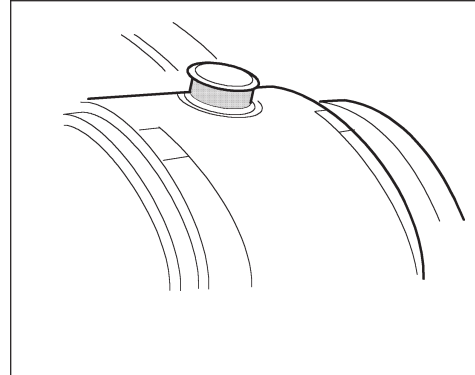

Fig. 3

### Wear Indicator

For Coupling mechanism and front/rear friction pads. (Fig. 4)

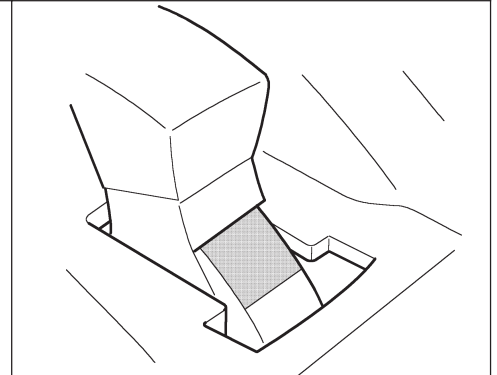
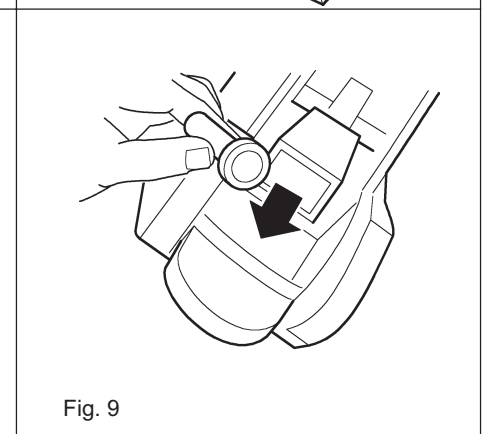
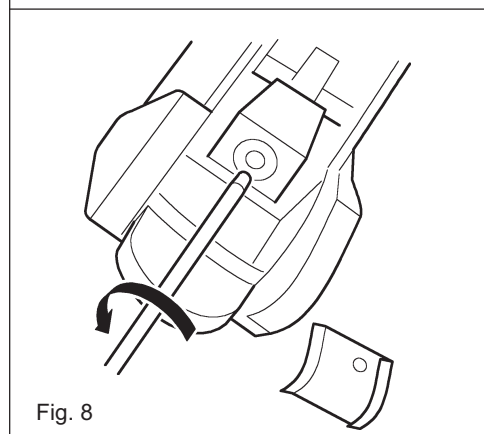
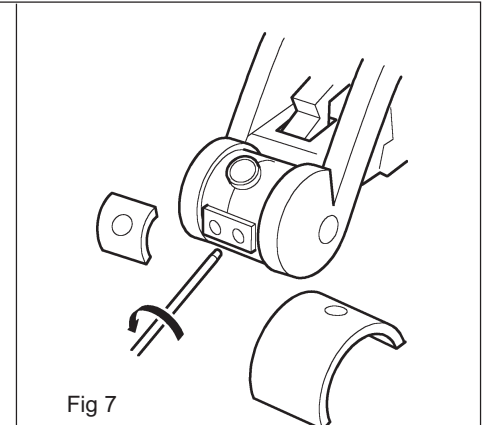
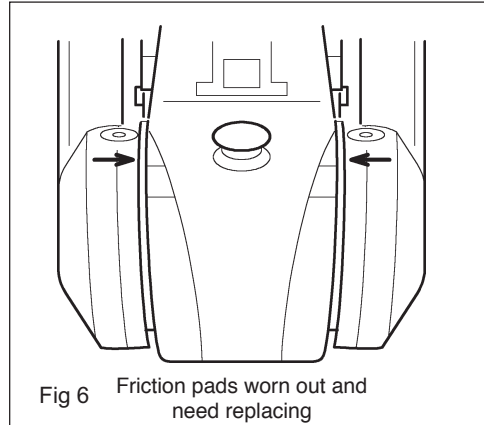
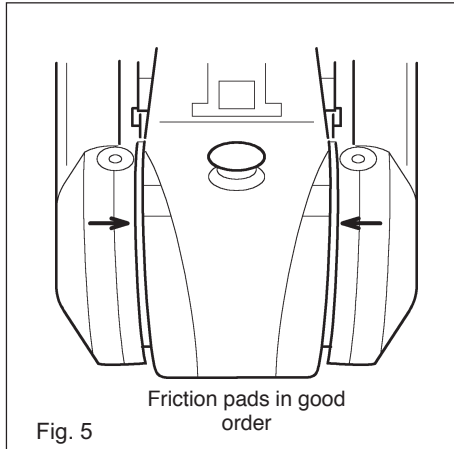

Fig. 4



## PREPARING FOR THE ROAD

- Wear of the coupling ball and mechanism can be easily monitored. If the green section is visible (when coupled to your towball) then the front/rear friction pads, coupling ball and mechanism are in order.
- If the red lower section obscures the green section then you need to check these parts immediately.





## Friction Pads Replacement

- Unscrew the 2 screws which are under the soft dock by using the special torx tool (UK version only). (Fig. 7)
- Remove screw from back plate. (Fig. 8)
- Remove friction pads. (Fig. 9)

## Loading Capacity

The AKS can be utilised to tow vehicles up to a gross weight of 3000kg and a maximum nose load of 100kg.

## AL-KO SECURE WHEEL LOCK

You must register your key, should you fail to do this you will not be able to order a spare key or obtain lost or stolen keys.

*This is how it works:*

- On the Al-Ko Secure registration card you will find an exclusive security number.
- Please register your key by telephoning 0870 7576788 or 0044 1926 818500.
- You will be required to provide the chassis number of the caravan.
- You will need to provide us with a password and supply answers to three security questions.
- Make a note of your password and keep it in a safe place.
- Also keep your registration card safe.
- Take your registration card with you when you are travelling with the caravan.
- Always keep your registration card separate from the lock.

## Safety Information

- Always secure the caravan against movement (chock the wheels, couple to towing vehicle).
- Never leave Secure parts (key, locking bolt, registration card) in the caravan.
- Always remove Al-Ko Secure before moving the caravan.
- After any attempt at theft has been made on a locked Al-Ko Secure, the caravan must be inspected in an Al-Ko Approved Service Workshop.
- Always keep the key in a safe place.
- Keep the lock set and registration card separate from the keys.
- The lock parts and key do not have a registration number, therefore keep the registration card in a safe place.
- Caravans with twin axles have two locks, keep each lock set in a separate place. The sets are not interchangeable!

**Note: Read the operating instructions and act in accordance with them. Keep the operating instructions for general use. Follow the safety instructions as well as the warning information.**



## PREPARING FOR THE ROAD

### ASSEMBLY

We recommend the use of a side-lift jack for easier fitting of AI-Ko Secure when used on a tandem axle caravan. (Order No. AI-Ko Jack Set 1389235).

- Align the wheel so that the receiver can be seen in the centre of the rim opening. **DO NOT** use the rim opening in which the tyre valve is fitted. (Fig. 1)
- Unscrew the plastic cap from the receiver and store in the tool kit box. (When AI-Ko Secure is not in use, always screw the plastic cap in place). (Fig. 2)
- Insert the locking bolt into the rim specific insert. (Fig. 3)
- Insert the locking bolt socket key. (Fig. 4)
- Line up the locking bolts and assembly with the receiver. (Fig. 5)
- Tighten the locking bolt socket using the wheel spanner provided (or torque wrench as shown) to wheel torque. (Fig. 6)
- Remove the locking bolt socket key. (Fig. 7)
- Insert barrel lock. (Fig. 8)
- Hold the lock fast and lock. (Fig. 9)
- The AI-Ko Secure is now fitted. (Fig. 10)

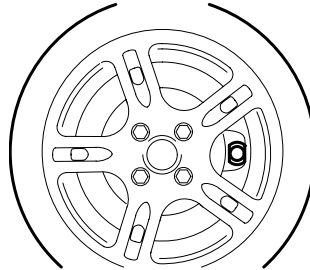

Fig. 1

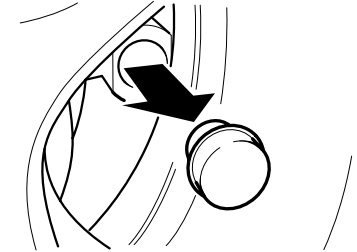

Fig. 2

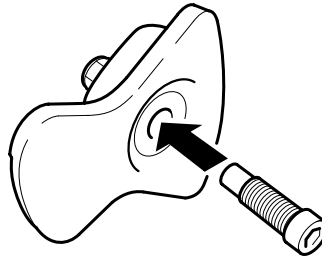

Fig. 3

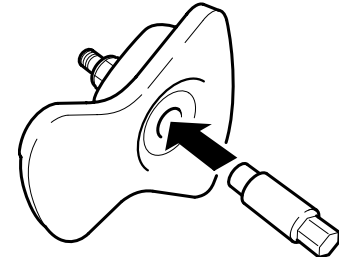

Fig. 4

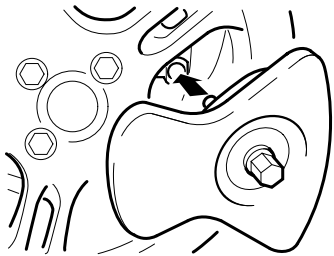

Fig. 5

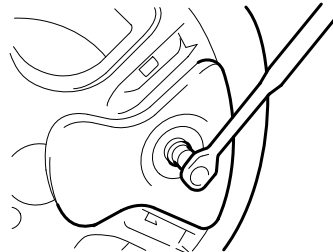

Fig. 6

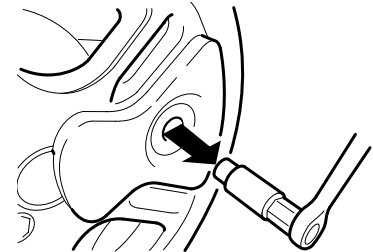

Fig. 7

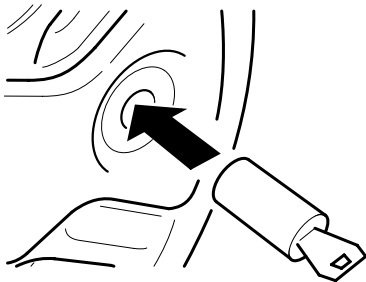

Fig. 8



Fig. 9

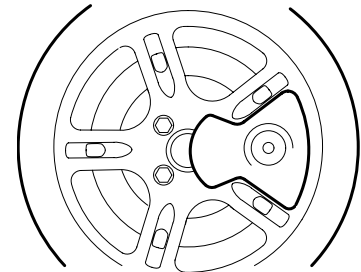

Fig. 10



## PREPARING FOR THE ROAD

---

### TWIN AXLE CARAVANS

Fit the front lock first by aligning the wheel so the receiver can be seen in the centre of the rim opening. Chock front wheel and opposite wheel. Jack the caravan (preferably using the Al-Ko side lift jack) until the rear wheel is clear of the ground. Fit the second lock by aligning the wheel as described previously

**Note: Lost components phone 0044121 5050400.**

In the event of attempted theft report to police and your insurance company.





## SECONDARY BRAKING CABLE (Break away device)

**Purpose** - To apply a trailer's brakes if it becomes separated from its towing vehicle. Having done this, the cable assembly is designed to part, allowing the trailer to come to a halt away from the towing vehicle.

**Construction** - A thin steel cable, possibly plastic coated, and fitted with a means of attachment for connection to the towing vehicle.

**Operation** - In the event of the main coupling of the trailer separating from the towing vehicle, the cable should be able to pull tight, without any hindrance, engaging the trailer's brakes.

**NOTE:** The breakaway cable should never become taut during normal use.

### Correct procedure for use:

- Regularly check the cable and clip for damage. If in doubt, contact your dealer or service agent.
- Make sure the cable runs as straight as possible and goes through a cable guide underneath the trailer coupling.
- Determine whether or not the towbar has a designated attachment point (i.e. a part specifically designated by its manufacturer for a breakaway cable).

### Where a designated attachment point is provided on the towbar:

*Either:*

- Pass the cable through the attachment point and clip it back on itself (Fig 1).

*Or:*

### Where no designated attachment point has been provided on the towbar:

**Fixed ball** - Loop the cable around the neck of the towball. If you fit the cable like this, use a single loop only. (See Figs. 2 and 3).

**Detachable ball** - You must seek guidance on procedure from the towbar manufacturer or supplier.

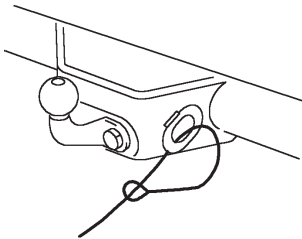

Fig 1

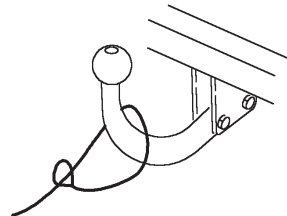

Fig 2

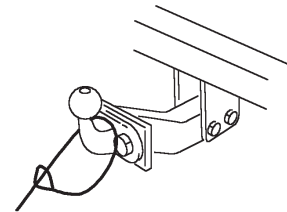

Fig 3



## PREPARING FOR THE ROAD

### Other means of attachment:

In some instances it may be possible to attach the cable assembly:

*Either:*

- a) to a permanent part of the towbar structure, as long as this meets the approval of the towbar manufacturer/supplier,

*Or:*

- b) to an accessory sold for the specific purpose of breakaway cable attachment.

### When the breakaway cable is attached, check to ensure:

- a) that the cable cannot snag in use on the trailer coupling head, jockey wheel, or any accessory, e.g. a stabiliser, bumper shield, cycle carrier, etc.
- b) that there is sufficient slack in the cable to allow the towing vehicle and trailer to articulate fully without the cable ever becoming taut and applying the brakes.

**NOTE: For peace of mind you might wish to check the state of the cable by positioning the trailer and towing vehicle at extreme angles before setting off.**

- c) that it is not so slack that it can drag on the ground. If left loose, the cable may

scrape along the ground and be weakened so that it subsequently fails to do its job. The cable may also be caught on an obstacle when in motion thus engaging the trailer brakes prematurely.

*Having followed this advice, should you feel that a satisfactory coupling arrangement cannot be achieved, consult your trailer or towbar supplier or service agent.*

- It is a legal requirement that the secondary break away cable is used when towing.

### WHEELS

Check wheel nut torques regularly and particularly before a long trip for extra safety.

This service is available at all tyre service depots (inform them of the torque settings)

- The torque settings are:

ALLOY WHEELS	115Nm
STEEL WHEELS	88Nm
- Check wheel/tyres for signs of deterioration or damage.

**WARNING: After a wheel has been refitted, always recheck the torque after 20-30 miles use or 20-30 minutes travelling. Even if properly torqued up, it is occasionally possible for fixings to loosen should the wheel "bed in" on the hub.**

### TYRES

All tyres used on Lunar caravans, when inflated to the pressures recommended, are adequate for speeds up to 130 kph at the maximum specified laden weight of all models.

**Note: Maximum permitted speed in the U.K. is 60 mph and in the interests of road safety speeds above this are not recommended.**

### Tyre tread

A caravan is subject to the same criteria applied to car tyres, namely; a minimum of 1.6 mm tread pattern depth throughout.

### Tyre pressures

**Caravan and towing vehicle tyres must be at the pressures recommended for towing or heavy loading.** The pressures can be found in the towing vehicle handbook and under the caravan specification in the service handbook.

**Note: Pressures should only be checked when the tyres are cold, not after a journey or if the vehicle has been standing in the sun.**

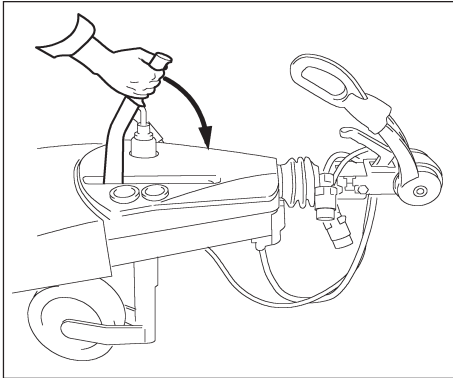

**To release the handbrake, push it forward and down using your body weight.**

**Note: “Failure to ensure that the caravan handbrake is completely off, can result in overheating of the brakes and failure of the bearings”.**

## Ground Clearance

Care has to be taken to prevent grounding of the caravan when traversing ramps and ground obstacles. If necessary ground clearance can be increased by removing the jockey wheel when travelling.

## Number Plate

A trailer must carry a rear number plate bearing the number of the towing vehicle and be illuminated at night. The number plate should conform to the same size and colour regulations as for cars. A reflective black and yellow plate may be used on a trailer towed by a vehicle with non-reflective plates and vice-versa.

## Manoeuvring

When pushing or pulling the caravan always use the grab handles correctly, do not snatch them and never push body panels, metal or glass reinforced plastics, as this can cause serious damage to the bodywork or mastic seals.

## Mirrors

The driver of the towing vehicle must have an adequate view of the rear.

If there is no rear view through the caravan it is essential that additional exterior towing mirrors are fitted.

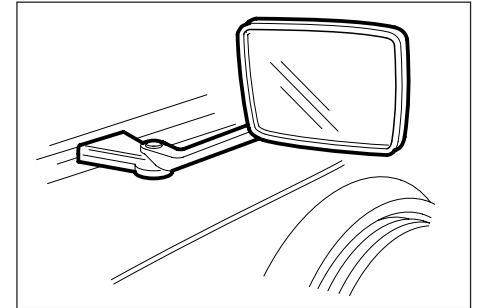

**Caution: Any rear view mirror must not project more than 200mm outside:**

- the width of the caravan when being towed.
- the width of the towing vehicle when driven solo.

**Note: Any rear view mirror fitted shall be ‘e’ marked and cover the field of view as stipulated by type approved requirements (Regulation 33 of the Road Vehicles [Construction and Use] Regulation 1986).**



## PREPARING FOR THE ROAD

### Road lighting

For your information the wiring diagram of the 13 pin connector is shown. These should be checked regularly and if in any doubt a qualified electrician consulted.

### Passengers

Passengers are forbidden to ride in a caravan with the exception of authorized test personnel.

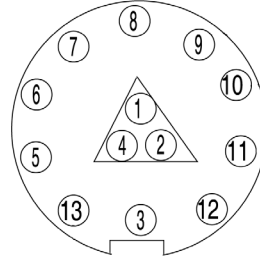

PIN No	COLOUR	DESCRIPTION
1	YELLOW	LEFT IND
2	BLUE	FOG
3	WHITE	NEG FOR ROAD LIGHTS
4	GREEN	RIGHT IND
5	BROWN	RIGHT SIDE LIGHTS
6	RED	STOP
7	BLACK	LEFT SIDE LIGHTS
8	ORANGE	REVERSE
9	BLUE/BROWN	CAR +VE
10	RED/BROWN	FRIDGE +VE
11	GREEN/WHITE	FRIDGE -VE
12	EMPTY	
13	BLUE/WHITE	CAR -VE

13 pin plug wiring diagram



# ON THE ROAD

- Speed Limits ..... 22
- Pulling Off ..... 22
- Caravan Handling ..... 22
- Motorway Driving ..... 22
- Reversing ..... 22
- Changing a Wheel ..... 23
- Jacking Points ..... 23
- Stopping on a Hill ..... 24
- Arrival on Site ..... 24



## ON THE ROAD

### SPEED LIMITS

Normal road towing: 50mph

Motorways (including dual carriageways):  
60mph

### PULLING OFF

Let the clutch in smoothly.

Allow more engine speed to produce the power to move the additional weight of the caravan.

Avoid wear and tear on clutch and transmission by taking extra care.

Change gears smoothly.

Try not to jerk the clutch.

### CARAVAN HANDLING

Allow for caravan being wider than car.

Do not bump kerb with caravan wheels.

When passing other vehicles allow more than the normal clearance for driving solo.

Allow longer to get up speed to pass.

Allow for the vehicle being twice its normal length.

Do not suddenly swing out.

Carry out all manoeuvres as smoothly as possible.

Use nearside wing mirror to check caravan has cleared when overtaking.

Never let a 'tail' of traffic build up behind you. Always pull in to let others past.

### MOTORWAY DRIVING

1. Caravans may not be towed in the outside lane of a three or four lane motorway. (Reg. 12(2) of the Motorway Traffic [England and Wales] Regulations 1982).
2. Reduce Speed:
  - i) In high or cross winds.
  - ii) Downhill.
  - iii) In poor visibility
3. High sided vehicles cause air buffeting so extra care must be taken when passing or being passed. As much space as possible should be given.

### Reversing

Proficiency at reversing can only be achieved with practice and should be first attempted in a large open area.

Your caravan is fitted with an automatic reversing mechanism which allows you to reverse without the need to make any adjustments. **After reversing, the caravan should be drawn forward at least 1 metre to restore the brake shoes to their normal position before applying the hand brake.**

**Note: Reversing uphill will be difficult if either wheel brake or brake linkage is overadjusted. You need to ensure that the brakes have been disengaged before reversing uphill.**

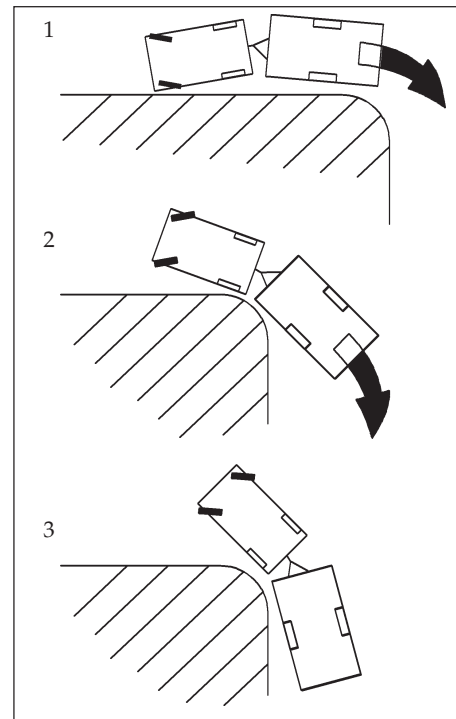

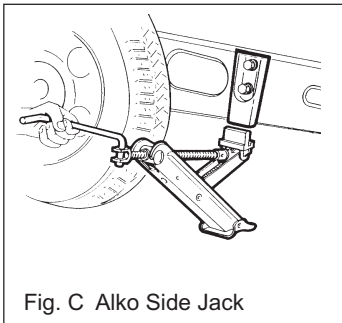
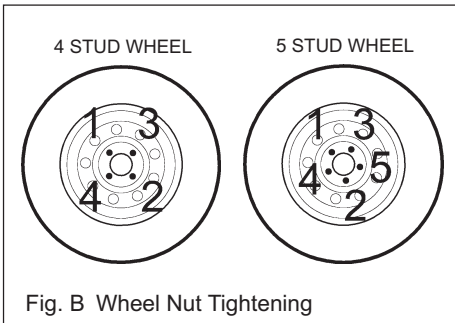
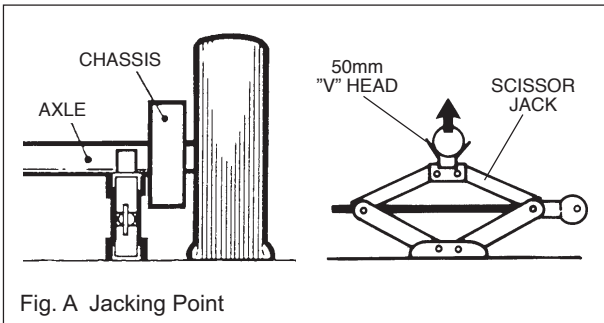

## CHANGING A WHEEL

1. Leave caravan hitched to towing vehicle and ensure handbrake is applied.
2. Lower corner steadies (as safety measure) on the side that the wheel is being changed to stabilise the caravan.
3. Use wheel brace to slacken off wheel nuts on the wheel to be changed.
4. Position jack under the axle at the appropriate jacking point (see fig. A).
5. Jack up the caravan until the wheel for removal is just off the ground.
6. Remove the wheel bolts, wheel trims and remove the wheel.
7. Fit spare wheel and reverse the above procedure.
8. When replacing the wheels you should tighten the nuts in rotation diagonally. Tighten all nuts equally, according to Fig. B, to 88Nm (65 lb/ft)

for steel wheels and 115Nm (85lbs/ft) for alloy wheels using a torque wrench or have checked as soon as possible.

**Note: When changing a wheel ensure:**

- a) that the correct wheel fixings are used.
- b) that there are clean, dry mating surfaces and clean, dry bolt/nut area.

**NB: Special nuts are supplied with alloy wheels and these can be used where a steel wheel is used as a temporary spare.**

If replacing an alloy wheel nut, a nut to the following reference should be purchased: M12 x 1.5 pitch, 26mm thread, 10.9 grade, 60 degree conical fixing, 19mm hexagon bolt head.

## IMPORTANT

When a wheel has been removed and replaced the torque of the wheel nuts should be re-checked after approximately 15 miles of running.

## JACKING POINTS

It is recommended that the jack is located in the correct position i.e. on the axle tube inside the chassis member (Fig. A). The reinforced axle mounting plate can be used as an alternative but the chassis-member itself **MUST NEVER** be used as a jacking point.

## Alko Side Jack

The Alko chassis is provided with the facility to fit an Alko side jack which can be fitted as an optional extra (Fig. C).



### STOPPING ON A HILL

Pulling off again can sometimes present a problem. The easy solution is:

- (i) Carry a good sized wedge shaped piece of wood with a rope or light chain attached.
- (ii) Attach the other end of the rope to the nearside rear grab handle.
- (iii) Place the wood behind the nearside caravan wheel.
- (iv) Carefully reverse the car slightly back down the hill, the caravan will stop against the wedge and turn.
- (v) Drive forward since this attempt to move up the hill will now not involve pulling the full weight of the caravan until the car has gained some traction.

### Ramps

Take care to prevent fouling when traversing ramps or other ground obstacles.

### ARRIVAL ON SITE

**Note: Check and observe site regulations.**

#### 1. Selecting a pitch.

Do not pitch in such a position that your outfit will obstruct others coming in.

Try to choose an area which is dry, reasonably level and preferably with a hard base.

If you have no alternative but to pitch on a slope ensure that, for when you leave, you are facing down the slope.

It is good practice to chock the wheels of the caravan when parked on a slope even though the caravan brakes are applied.

#### 2. Siting/Unhitching

When you arrive at your site and have been allotted a pitch:

Manoeuvre your caravan onto your pitch (if you have reversed read the notes on page 20), apply the handbrake, remove the brake safety cable, unplug the 13-pin plug and store these in the sockets provided on the 'A' frame cover.

Unclamp and lower the jockey wheel to the ground. Re-clamp the jockey wheel after first unscrewing slightly.

Free the coupling by winding up the coupling head until it is clear of the 50mm ball. Replace the tow ball cover and then park your car.

#### 3. Levelling the caravan

Levelling must be carried out in both directions in order for the refrigerator and other equipment to function correctly.

The positioning of the jockey wheel can be used to help level the caravan.

Lower the corner steadies until they are in firm contact with the ground. DO NOT use the steadies as a jack they are only a means of stabilising the caravan.

Levelling pads or boards should be used under the steadies where the ground is soft or uneven. Stepped levelling boards can easily be constructed (Fig. D).

In extreme cases where it is necessary to raise a wheel off the ground for levelling purposes, further adequate support should be applied so that the steadies do not take any undue strain.



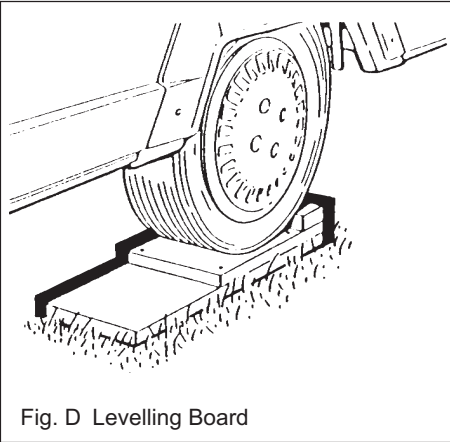

Fig. D Levelling Board

### Exterior Door

To prevent distortion of the body, the caravan must be always correctly sited and levelled. Failure to site the caravan correctly may prevent the exterior door from closing properly.

**Attention:** Always disconnect the electrical connector between the towing vehicle and the caravan before connecting an LV supply to the caravan and before charging the caravan battery by any other means.





**FIRE  
&  
SAFETY**

- In Case of Fire ..... 28
- Smoke Alarm ..... 28
- Carbon Monoxide Alarm ..... 29
- Fire Extinguisher ..... 29
- Children ..... 29
- Ventilation ..... 29
- Security ..... 30
- Theft ..... 30
- Chassis Number ..... 30
- Additional Security ..... 30
- Datachip Security Card ..... 30



## FIRE & SAFETY

### FIRE ACTION

1. **GET EVERYONE OUT**
2. **TURN OFF GAS VALVE**
3. **RAISE THE ALARM AND CALL THE FIRE BRIGADE**
4. **DISCONNECT THE MAINS ELECTRICITY SUPPLY**
5. **TACKLE THE FIRE IF SAFE TO DO SO**
6. **MAKE YOURSELF FAMILIAR WITH THE INSTRUCTIONS ON YOUR FIRE EXTINGUISHER AND THE FIRE PRECAUTION ARRANGEMENTS ON THE SITE**
7. **CHECK FIRE EXTINGUISHERS REGULARLY**
8. **CHECK GAS PIPING AND MAINS ELECTRIC WIRING ANNUALLY**

**If you suspect a gas leak - never use a naked flame to search - always use soapy liquid or - better still - call your caravan dealer.**

### Important

With any extinguisher, never use it on a pan of fat - this is very dangerous - always use a fire blanket.

To tackle a pan fire: First of all, if possible try to turn off the gas. Make sure you are aware of the position of the gas isolating taps - usually placed in the sink unit cupboard.

Never throw a flaming pan outside, keep your hands away from the flames and smother the flame.

Try to remain calm.

Do not throw the blanket on the fire but place over the pan paying particular attention to the handle.

### Fire Precautions

Make sure you are aware of the operation and location of escape windows and doors.

It is advisable to carry a fire extinguisher (a dry powder is recommended) positioned as near to the exterior door as possible.

A fire blanket approved to BS 6575 is also advisable positioned as near to the cooking area as possible.

Check the fire regulations on arrival at sites. Do not leave pans on the stove unattended. Do not leave matches within easy reach of small children.

Never leave small children alone in the caravan.

Do not smoke in bed.

Do not block up ventilators.

### SMOKE ALARM

The Code of Practice requires that a smoke alarm is fitted in your caravan. Every new

manufactured caravan has a smoke alarm fitted as standard equipment.

### Connecting the battery

Your alarm requires one 9 volt battery to power the smoke detector portion of the unit. Under normal use, the battery powering the smoke detector should last approximately one year. See label inside smoke alarm lid for suitable batteries.

With a pencil, write the date of battery installation on the inside of the cover to remind you when to replace the battery.

Lift battery from battery holder and snap battery connectors to battery. They fit together only one way.

Gently push battery into battery holder.

To close the cover match up snap-in hinges and gently press together until base and cover snap together.

### IMPORTANT

**When the battery is first connected the alarm may sound for 2-3 seconds.**

**THIS IS NORMAL.**

**It means the battery is connected correctly.**

### Replacing the battery

Test the alarm for correct operation using the test button whenever the battery is replaced.



When battery power is low and replacement is necessary, the alarm will 'beep' about once per minute for at least 30 days. The battery must then be replaced. Replace battery if the alarm does not sound when the test button is pressed. For maximum reliability, replace battery at least once a year.

## Testing the Smoke Alarm

It is recommended that you test the smoke alarm once a week to be sure the unit is working. It will also help you and your family to become familiar with the sound of the alarm.

When you press the test button it simulates the effect of smoke during a real fire. So, there is no need to test the alarm with smoke.

Press and hold the test button until the alarm sounds (it may take up to 10 seconds). The alarm will stop sounding shortly after the button is released.

## Cleaning the Smoke Alarm

Clean the smoke alarm regularly. Use a soft bristle brush or the brush attachment of your vacuum cleaner to remove dust from the sides and cover slots where the smoke enters. Keep cover closed while cleaning. Do not vacuum or brush inside the smoke alarm. To clean the cover, remove it completely and use only mild soap and water. Dry cover thoroughly before replacing it.

## Warning: Do not paint the Smoke Alarm.

Other than the maintenance and cleaning described above, no other customer servicing of this product is required.

## CARBON MONOXIDE ALARM

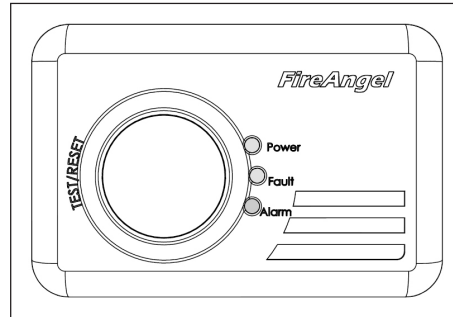

Your carbon monoxide alarm is located on the underside of the offside or nearside locker. Under normal operating conditions the power pack will last for the lifetime of the product (7 years). Batteries for this product are non replaceable.

It is recommended that the alarm is tested weekly by pressing the test/reset button.

## LED Indicators

**Power.** In normal operation the LED will regularly flash green.

**Fault.** If a fault is found in the sensor and circuitry or the power pack becomes low then the detector will emit a single chirp once per minute and the fault LED will flash yellow once per minute for 30 days.

**Alarm.** When sufficient carbon monoxide is detected a loud audible signal will be emitted and the alarm LED will flash red once every second. When alarm is tested the LED will illuminate red.

## FIRE EXTINGUISHER

It is recommended that a 1kg (2lb) minimum capacity dry powder fire extinguisher be carried inside your caravan at all times. (NCC recommend types marked 5A34B).

When using a dry powder extinguisher it is suggested that the caravan be evacuated until the powder has settled, to avoid inhalation.

A fat pan fire should not have a fire extinguisher aimed at it. It should be smothered with a fire blanket.

## Children

Do not leave children alone in the caravan in any event. Keep potentially dangerous items out of reach, as at home e.g. matches, drugs etc.



## FIRE & SAFETY

---

### Bunks

Where fitted, the foldaway bunk has been tested to 70kg (11 stones) and has a recommended limit of 57kgs (9 stones). Safety features are included but care should always be taken, particularly if the child is under 3 years of age. Bunks are not suitable for children under 6 years old without supervision.

Solid (fixed) bunks have a recommended limit of 75kg (12 stones).

### Ventilation

All caravans comply with British Standards EN1645. The ventilation points on your caravan are fixed points of ventilation which are stated by the British Standards.

Ventilation is provided at floor and ceiling level and care should be taken to ensure these remain clear of debris by regular cleaning.

### **Under no circumstances must these vents be blocked or obstructed.**

It is advised that fixed ventilation points are checked and cleaned (if necessary) on a regular basis.

Additional night time ventilation is obtained by releasing the window catches and placing them in the second groove on the frame catch.

You must maintain adequate spacing of combustible materials from sources of heat (eg heater)

Do not use independent gas appliances inside the caravan.

We advise that the user instructions for the fitted appliances are studied in addition to the information in this handbook.

### **Petrol/Diesel Fumes**

The fitting of a tail pipe to your car exhaust will reduce the possibility of fumes entering your caravan through the front fixed ventilation points.

## SECURITY

### **Caravan theft**

The theft of a caravan can occur in the most unlikely circumstances; from a motorway service area, even from an owner's driveway.

Secure all windows and doors when your caravan is unoccupied even if only for a short length of time.

### **Vehicle Identification Number (V.I.N.)**

Record your caravan V.I.N. which can be found on **any of the eye level windows.**



# SERVICES

Water .....	32
Gas .....	38
Electricity .....	42



## SERVICES

### STANDARD WATER SYSTEM

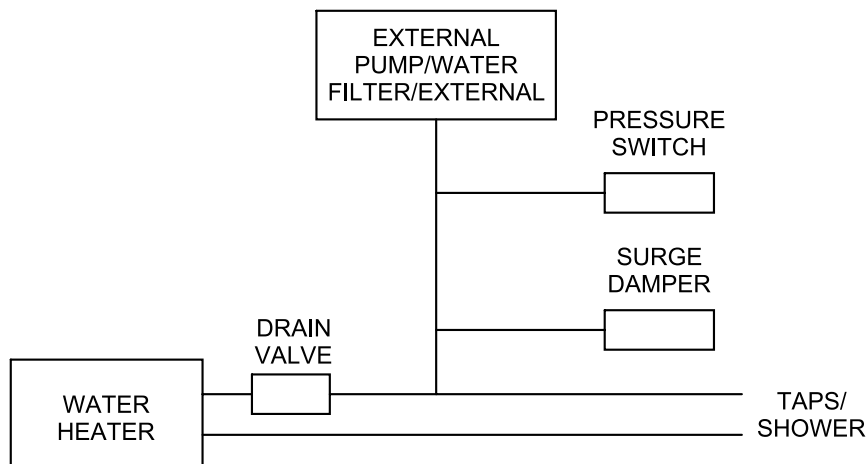

### Surge Damper

The surge damper prevents water hammer and also reduces switch hunting on and off.

The surge damper is a completely sealed unit and requires no servicing, however, as with water systems, the complete system should be drained in the winter.

### The Filter

The filter attaches directly to the pump and incorporates a non- return valve designed to prevent dirt and grit from entering the pump valves as this will cause pump failure. The filter is fitted during installation to protect the pump.

### Pressure Switch

The pressure switch is operated by the opening and closing of the taps/shower. When a tap is opened the pressure in the system is altered which activates the pressure switch supplying power to the selected pump.





## Maintenance

Poor pump performance may be an indication that the filter has become blocked by debris. The filter is easily removed for inspection and cleaning:

- Remove circlip and unscrew filter from pump.
- Pull two halves of filter apart to expose the strainer mesh.
- Remove any debris and replace strainer mesh in position.
- Ensure the rubber seal is correctly seated in the groove on the outlet side of the strainer before pushing the two halves firmly together.
- Attach to the pump and replace the circlip.
- See arrow on pump housing for flow direction.

## Care of your Submersible Pump

Care should be taken to ensure that the pump is not allowed to run dry for appreciable periods. Whilst the design will allow some dry running, such as when the tank requires refilling, the pump life will be appreciably lengthened if care is taken to minimise dry running.

## Aquaflow Caravan Filler

There is a special filler fitted for use with the Submersible Pump which not only provides a recessed, locking filler cap for water input, but also a polarised power take-off point complete with input plug. This is part of the original equipment for Delta models only.

### The Water System for Delta Models

A submersible pump is used for pumping water from an external container into the inboard tank of the caravan.

### To Operate The System

First ensure that the drain tap on the inboard tank is closed. Place the pump inside your filled container. Place the hose into the filler cap on the side of the caravan. Plug in the 12 volt plug into the socket on the filler cap. When the water container is empty unplug the 12 volt -do not allow the pump to run dry.

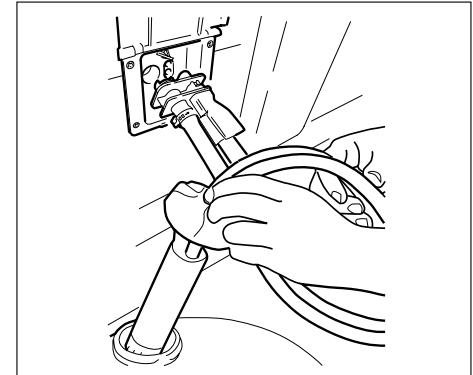

## WATER PUMP

The separate plug-in pump assembly consists of a Crystal Maxi pump, hose and plug. The plug provides connection of both water supply to the caravan and 12V dc electric power to the pump. A dust cover is fitted to the connecting dual hose to prevent contaminants falling into the water container.

The Crystal Maxi pump is a completely sealed unit designed for intermittent use. It is NOT self-priming and therefore to ensure proper performance, the pump MUST ALWAYS be fully submersed in water BEFORE plugging into the wall socket.



## SERVICES

### Initial connection to fresh water supply

1. Fill the fresh water container and place it alongside the wall socket located in the offside external wall of the caravan.
2. Ensure the pump isolator switch at the control panel inside the caravan is switched off.
3. Open the 'hot' kitchen tap. Ensure all other taps are closed.
4. Place the pump into the water container outside the caravan, taking care to ensure the pump reaches the bottom of the container.
5. Lift the lid of the wall socket and fit the pump assembly plug into the socket. Ensure it is pressed in fully.
6. Adjust the dust cover to fit over the opening in the water container to keep contaminants out.
7. Switch on the pump isolator switch at the control panel inside the caravan.
8. Wait until water flows freely from the 'hot' kitchen tap. Allow to flow for a few more seconds to ensure release of any trapped air in the water system, then turn the tap off.

Repeat the same procedure with the 'cold' kitchen tap.

If the system has been drained, the above procedure **MUST** be repeated **EVERY** time the water container is filled.

Switch on the pump isolator at the control panel.

Once it has been properly connected, and a tap is turned on, the pump is activated automatically by a pressure switch.

### Fault Finding

1. *Pump runs very noisy but does not pump water.* Likely to occur after water container has been refilled. Pump is air locked. *Cure:* unplug from socket allowing pump to flood, and reconnect by plugging in again. The correct sequence when refilling the container is to unplug, replace pump in container, then reconnect.
2. *Pump fails to deliver water.* The most likely cause will be air in the system. To remedy this, switch off the pump and shake the pump assembly in the water. Then switch on again. Alternatively, make sure the assembly is positioned fully into the housing.
3. *Pump does not run at all.* If not due to blown fuse or faulty connections, then most likely cause is excessive continuous running. *Cure:* replace pump.

**Never allow the pump to run dry.**

**Never allow the pump to run continuously for more than 15 minutes.**

**Note:** When refilling the water container, the pump assembly may be left plugged into the wall socket so that the pump can be kept off the ground by inserting the hose into the groove on the underside of the plug. But, the pump assembly **MUST** be unplugged **BEFORE** replacing the pump into the refilled water container.

### STERILISING

When cleaning the water system at the start or the end of the season, it is advisable to use the sterilising fluid, e.g. Milton 2, Chempro SDP or similar. It is recommended that for this operation you use any empty filter body as the fluid reduces the effectiveness of a new filter.

Flush the system thoroughly to remove the effective fluid traces.

After sterilising the system at the start of the season it is recommended that a new filter cartridge is fitted.

### NOTES

- Never allow the pump to run dry. Always ensure that the pump is submerged in the water or the life of the pump will be reduced.
- Before winter storage, the water system must be completely drained.
- Clean the water system at the start and



end of the season with sterilising fluid (see notes under sterilising).

## Water System Winterisation

Caravans may be in use all year round, but when not in use, even for short periods, this procedure should be followed. One night of freezing temperatures is all that is required for expensive permanent damage to water system components.

- a. The whole system must be drained.
- b. Open kitchen taps. Lever taps should be lifted in central position, leave taps open permanently after system drain down.
- c. Open bathroom and shower taps (including shower on/off control rose) and leave open permanently after system drain down.
- d. Shake the shower head to remove the water held there and in the hose. At this point it is recommended to remove the shower head from the hose. Even the smallest amount of frozen water can result in the shower head cracking.
- e. Remove cold water drain plug (if fitted), normally located under the caravan near to the water inlet socket.
- f. If possible remove any remaining water from system plumbing at water inlet sockets and in between in-line pressure switch plumbing.

- g. Disconnect cartridge or in-line filters from plumbing.
- h. Submersible pumps should be shaken out and stored in a dry place.
- i. Drain the external shower bridge connection (including models without external shower) on the Ultraflow housing by inserting the shower connection or open the valve by means of a tool to push on the black rubber pad of the valve.

## Cleaning the Water System and Portable Water Tanks

The water systems, and in particular storage tanks, in caravans are susceptible to contamination by bacteria if care is not taken with their use and cleaning. The symptoms caused by bacterial contamination are not purely limited to gastro-intestinal diseases, but may also manifest themselves as ear, nose, throat, eye or skin infections. It is therefore important that you carry out the following procedure prior to using the caravan each time, even if you boil or filter all water you use for drinking.

## Water Containers

1. All water remaining in the container should be disposed of so that the container is empty.
2. The outside of the container should be thoroughly cleansed and washed down to

remove any dirt, dust or other contaminants. Water at a suitably hot temperature containing an appropriate detergent is recommended for this purpose.

3. Water should be placed in the container, swirled around, then emptied out.
4. The container should then be totally filled with water containing an appropriate disinfectant/sterilant solution and allowed to stand for the recommended contact time (e.g. Milton for 15 minutes).
5. The solution should be emptied from the container.
6. The opening of the container should be cleaned thoroughly with an appropriate pre-prepared wipe impregnated with a disinfectant/sterilant.
7. The container should be inverted whilst stored overnight (if possible).
8. The container must be filled with mains water only and mains water only should be used for the above cleaning procedure.
9. On no account should garden hoses be used to fill water tanks.

## Water Systems

1. Drain down the system. (Open all taps to allow air in, enabling the system to drain quickly.)



## SERVICES

---

2. Remove any water filters fitted, and replace with a short length of hose or empty filter cartridge (this will ensure the filter is not affected by the disinfectant/sterilant solution).
3. Fill the system by using the pump with a disinfectant/sterilant solution. (Check that the solution at full strength appears at all taps/showers). Allow to stand for the recommended period of time.
4. Drain the system down using the water systems internal flip switch located under the front off-side bed.
5. Thoroughly clean the outside of all taps/connectors with a cloth soaked in the disinfectant/sterilant.
6. Flush the system through with clean drinking water until no traces of disinfectant/sterilant can be detected at any tap.
7. Replace the filter.

Suitable sterilising chemicals are available from your caravan dealer, accessory shop, chemists or home-brew shops. It is not, however, recommended to use bleach or sodium metabisulphite.

### Setting Up the Water System

1. Replace/close all drain valves.
2. Replace shower heads and tap spouts.
3. Close all taps.
4. Refit old filters:
  - a. Check all plumbing connections.
  - b. It is recommended at this point to sterilise your water container and flush the system through with sterilising fluid.

#### **Note:**

**Frost damage cannot be claimed under warranty.**



## PRESSURE SWITCH

### Operation

The pressure switch detects the opening or closing of any tap in the system and switches the pump on or off accordingly. It is located near the water heater.

### To prime if fitted with a submersible pump:

1. Trapped air in the submersible pump will not allow the pump to prime. Air can be released by gently shaking the pump under water while the pump is in the water tank but is switched off.
2. If an external submersible pump is used, place the pump in the water before connecting to the side of the van.

At normal flow rates the pump should operate continuously — but at low rates the pressure switch will cycle on and off to maintain back pressure in the pipework.

### Adjusting the pressure switch:

If the battery voltage is not constant, cycling may occur. This can be minimised by adjusting the switch's diaphragm sensitivity as follows:

1. With the system properly primed, close all taps and showers.

2. Leave the power supply turned on.
3. Tighten the adjusting screw (clockwise). The pump should now be running.
4. Partly open one cold tap to allow water to flow at about 1 pint per 15 seconds.
5. Now slowly loosen the adjusting screw until the switch starts to click. The switch will then be properly adjusted.

### Helpful Hints

- a) If the pump will not run:
    - Pump could be faulty or a wire disconnected.
    - Check that the pump isolating switch is turned on.
  - b) If the pump cycles on/off:
    - Battery voltage may be too low (at or below 10.5 Volts). Adjust switch (see text) and/or recharge battery.
    - Check for air or water leaks in taps and piping. Re-adjust pressure switch.
    - Non-return valve may be held open by grit.
- Study the exploded drawing and remove the three assembly screws to gain access to the non-return valve.
- c) If a pump motor runs steadily and will not stop:
    - Battery voltage may be too low (at or below 10.5 volts)

- Check all connections in the pipe-work.
- Remove the adjusting screw, if motor still runs, pump is probably air locked. Turn off the isolator switch and reprime the pump (see text).

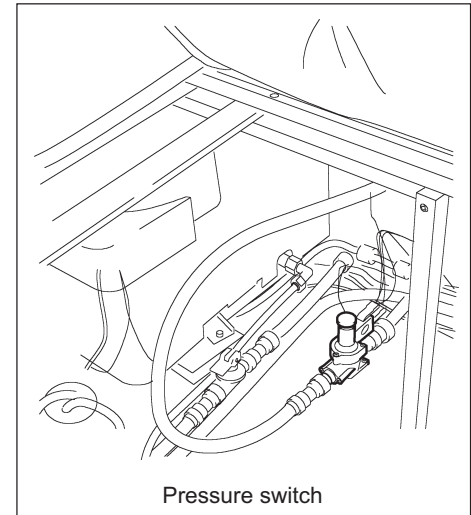



## SERVICES

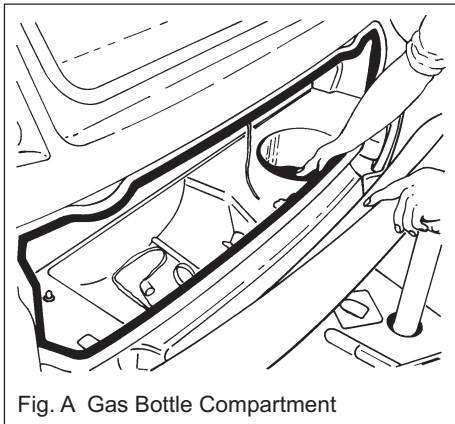

Fig. A Gas Bottle Compartment

### GAS

#### GENERAL INFORMATION

##### Gas Bottles

Bottled Liquefied Petroleum Gas (LPG) is the most convenient portable source of fuel for your caravan.

Make sure that heating and cooking appliances and the gas cylinders are switched off before you move the caravan.

Regularly check flexible gas hose, joints and connections for tightness. Finally make sure that each gas appliance is working efficiently to the recommendations of the appliance manufacturers.

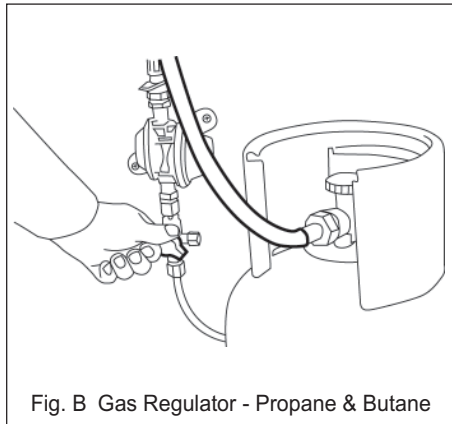

Fig. B Gas Regulator - Propane & Butane

In all cases the cylinder contents are in liquid form under pressure from the gas above it, and the pressure is only dependent on the type of L.P.G. and its temperature.

When gas is supplied the pressure in the cylinder is slightly reduced and liquid "boils" off to restore the balance. This action cools the liquid and the cylinder, and condensation or even frost may sometimes be observed on the outside of the cylinder. The cylinder, when in use, is always cooler than the surrounding air so allow plenty of circulation in cool weather and do not cover the cylinder with a "cozy" in the winter.

Butane works satisfactorily at temperatures down to 2° C. Propane should be used for temperatures below this, therefore for all year round caravanners, Propane is of greater use.

There are different sizes of bottles available and it is better to consult your dealer for advice. Gas cannot be supplied from the bottle without an approved regulator.

Hoses connected from regulator to the caravan supply should be made from Neoprene and comply with EN1949. Hoses have a limited life and should be inspected regularly.

The gas cylinders have a recess in the gas bottle compartment into which the cylinders should be restrained by means of the straps provided.

If cylinders are used outwith this compartment you must ensure 1) they are adequately supported b) ventilation is not blocked c) damage will not be caused to fixtures and fittings.

Never use a gas cylinder on its side - always stand cylinders upright - keep them in the gas locker provided (Fig. A).

Please note that the Gas Locker Box is not a watertight compartment.



If you should suspect a gas leak turn off the gas at the bottle and ventilate the caravan by opening the door and windows. Do not operate anything electrical and remove everyone from the caravan until the gas has dispersed. It is part of your annual service to inspect all gas pipes and appliances.

## Changing a Gas Cylinder

Before commencing to change a gas cylinder ensure that the valve on the cylinder is turned fully off. Turn off all gas operated appliances.

Remove the gas hose from gas cylinder.

Before refitting a gas cylinder, ensure that all gas operated appliances are turned off – particularly after winterisation. Ensure all connections are secure.

## The regulator

Your caravan is fitted with a regulator (capacity 1.5kg/hr) as standard equipment (Fig. B). This is located in front gas bottle locker. The gas regulator has a working pressure of 30mbar and is suitable for both propane and butane liquefied petroleum gas.

**Note:** Regulator valves should always be in the 'OFF' position when towing.

The 30mbar bulkhead mounted regulator fitted to the caravan requires a 'pigtail' connector for use with UK LPG cylinders, see your dealer for details.

To effect a safe connection with a European cylinder, you will need to obtain a 'pigtail' connector appropriate to the cylinders available in the country you are visiting.

**DO NOT** use the conventional cylinder-mounted 28mbar/37mbar regulators as the gas pressure is not compatible with the appliances installed in your new caravan/motorhome.

## Hoses

Inspect flexible hose(s) regularly for deterioration and renew, as necessary, with approved type. In any case not later than the expiration date marked on the hose. LPG hoses should be routinely replaced at intervals not exceeding 5 years or as recommended in manufacturers' instructions. Any hoses that show signs of splitting, wear or damage should be replaced irrespective of age.

If the gas supply hose is to be left disconnected for an extended period ensure the open end is protected against the entry of dirt or insects.

## TYPES OF GAS

### Butane

Butane is supplied in the U.K. in blue bottles.

Butane is suitable for use at temperatures down to 2°C, but will not work below that temperature.

### Propane

Propane is supplied in red bottles which have a left-hand threaded connector.

Propane will work at temperatures as low as -40°C and is therefore suitable for winter caravanning.

Make sure that heating and cooking appliances are turned off, and also the regulator at the gas cylinders before travelling.

**Never allow modification of LPG systems and appliances except by qualified persons.**



## SERVICES

### GAS SAFETY ADVICE

#### Facts about LPG

LPG is not poisonous.

Bi-products are harmless.

There is danger if all air and oxygen were excluded. (Ventilation holes must be kept clear at all times).

LPG has been given a smell by the manufacturers in order to identify leaks.

#### Awning Spaces LPG Appliance Exhaust

There is no danger of pollution of an enclosed awning space by the LPG exhaust from a refrigerator venting into it.

Space heaters may produce sufficient exhaust to pollute the awning space, if it is totally enclosed, from a general comfort, smell and hygiene point of view. In the extreme case there could be a build up of carbon dioxide to a dangerous level.

Caravan owners are advised to allow some fresh air circulation in the awning space when such appliances are in use.

### PRECAUTIONS

- a) Never look for a leak with a match. Always use a soap solution or its equivalent when testing connections. Do not operate any electrical apparatus whatsoever, especially light switches. If the leak is not obvious, the caravan should be evacuated and qualified personnel consulted.
- b) Avoid naked lights when connecting or changing a cylinder.
- c) Check the flexible hose frequently.
- d) The gas is heavier than air and therefore sinks to the lowest point.
- e) Keep bottle gas containers outside (and protected against frost). If they must be kept inside make sure they are well away from heat.

#### Ventilation

Fresh air circulation should be allowed below the caravan when appliances are in use and when flues terminate below the floor to allow free evacuation of the products of combustion. At least three sides of the underfloor space should always be kept open and unobstructed especially by snow. Do not make any additional openings in the floor.

Fixed ventilation openings are sited under gas appliances in various locations in your tourer.

#### WARNING

**Under no circumstances should fixed ventilation openings or gas appliance flues be obstructed in any manner as this could lead to a build up of dangerous carbon monoxide. Gas drop holes under appliances should also be kept clear at all times. Grilles and flues should be kept clean and free from dust.**

All ventilation complies with BS EN1645 and vents should not be obstructed in any manner as this could lead to insufficient fresh air. In this case the confined atmosphere becomes depleted of oxygen which leads to the formation of the highly poisonous gas 'carbon monoxide'. Carbon Monoxide is odourless, colourless and tasteless and will rapidly cause unconsciousness and death with little or no warning prior to collapse. THERE IS NO DANGER WHEN ADEQUATE VENTILATION IS PROVIDED.





## Roof-mounted Flue installations

All flue installations should be inspected once a year throughout their length for corrosion. Flues should be replaced if any sign of perforation is found. Ensure that the replacement is of an approved type.

## CONNECTION

Ensure that the gas regulator is correctly connected to the gas cylinder in gas bottle compartment and that the hose is tight. Before turning on the gas supply, ensure that all gas operated equipment in the caravan is turned off.

## Safety Hints

It is advisable to TURN OFF THE MAIN VALVE on the gas container when the caravan is left unattended for a period or is on tow, except where continuous operation appliances (such as a refrigerator) are in use. AVOID NAKED LIGHTS when connecting or changing a container. Make sure all appliances are turned off.

## Space Heating Appliances

Space heating appliances are to be completely extinguished before the caravan is moved and are not to be used when the caravan is in motion. Portable heaters should not be used.

## Manifold Locations

Heater and Water Heater manifold located underneath front O/S bed towards bulkhead.

Cooker and Fridge manifold located within compartment below cooker.

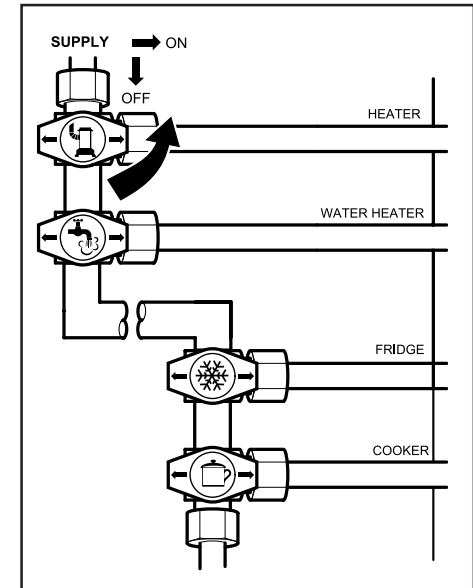



## SERVICES

### MAINS ELECTRICS

#### 230V Mains Electric Equipment Usage

For your convenience and pleasure this touring caravan is fitted with a 230V mains electrical installation.

**Please note:** It is possible that all of the 230V mains electrical equipment may not be able to be operated simultaneously. A typical UK caravan park mains hook up point provides a maximum output of 16 amps, although 10 amps is more common and on some continental sites the available output may be as low as 5 amps. If your loading exceeds the site supply it may trip the park's circuit breaker. Please check the available mains output with your site operator.

The following items need to be added together if used simultaneously.

#### 230V mains equipment typical consumption figures:

Fridge	0.5 amps
Charger	1.0 amps
Water heater (max)	5.7 amps
Blown air heaters	4.8 amps
Colour TV	2.5 amps
Microwave	3.5 amps
Air conditioning	4.0 amps
Truma Ultraheat (max)	8.3 amps
Kettle	3.2 amps
Alde central heating	10.0 amps

The mains wiring in Lunar caravans manufactured in the UK complies with the IEE Wiring Regulations, 17th edition, and is safe for the use in the UK. In the UK the on/off switching is always positioned in the live wire. Therefore when the switch is off the current is dead.

Correct polarity of the site supply should always be obtained by the use of a non-reversible plug and socket for connecting the cable to the caravan inlet.

Reverse polarity on overseas use: A plug in polarity tester is used to determine if the polarity is reversed, if so and the site connector is of the two pin type with the two metal strips for the earth, then the plug may be unplugged and inserted the other way round which will then reverse the polarity.

Unfortunately the overseas practice is not always to discriminate between live and neutral wires and the plugs are not necessarily non-reversible. They can be inserted the wrong way round. Consequently when switches are turned off the circuits are not dead. People may touch connections thinking that they are safe and they may still receive a shock.

A residual current device is already fitted to your Lunar Caravan. If a fault occurs and anyone makes indirect contact with a live lead the breaker should trip before a dangerous voltage is apparent.

It is essential that you understand the workings of each electrical circuit. Check supply cable terminals are firm and secure.

Check supply cables for wear and damage. Do not attempt modifications to the caravan electrical installation to accommodate a double supply.

### INSTRUCTIONS FOR ELECTRICITY SUPPLY

#### On Arrival at Caravan Site

1. Before connecting the caravan installation to the mains supply, check that:
  - (a) the main supply is suitable for your installation and appliances, i.e. 230 volts AC, frequency 50 Hertz.
  - (b) your installation will be properly earthed. Never accept a supply from a socket outlet or plug having only two pins, or from a lighting outlet.
  - (c) any residual current device (earth leakage circuit breaker) in the mains supply to the caravan has been tested within the last month. In case of doubt, consult the site owner or his agent.



**Note: Always disconnect the electrical connector between the towing vehicle and the caravan before connecting an LV (low voltage) supply to the caravan and before charging the caravan battery by any other means.**

2. Ensure that your caravan mains isolating switch (RCD) is in the off position. The MCB's are the breakers for the individual circuits.
3. Remove any cover from the electricity inlet provided on the caravan, and insert the connector of the supply flexible cable.
4. Remove any cover from the socket outlet provided at the site supply point, and connect the plug (at the other end of the supply flexible cable) to this. Switch on the main switch at the site supply point.

IN CASE OF DIFFICULTY CONSULT AN APPROVED ELECTRICAL INSTALLATION CONTRACTOR (WHO MAY BE THE LOCAL ELECTRICITY COMPANY). IT IS DANGEROUS TO ATTEMPT MODIFICATIONS AND ADDITIONS YOURSELF, LAMPHOLDER PLUGS (BAYONET-CAP ADAPTORS) SHOULD NOT IN ANY CIRCUMSTANCES BE USED.

## On Leaving the Caravan Site

5. Reverse the procedure described in Paragraphs 3 and 4 above.

IT IS IMPORTANT THAT THE MAIN SWITCH AT THE SITE SUPPLY POINT SHOULD BE SWITCHED OFF, THE SUPPLY FLEXIBLE CABLE DISCONNECTED, AND ANY COVER REPLACED ON THE SOCKET OUTLET AT THE SITE SUPPLY POINT. IT IS DANGEROUS TO LEAVE THE SUPPLY SOCKET OR SUPPLY FLEXIBLE CABLE LIVE.

## Periodically

6. Preferably not less than once a year, the caravan electrical installation should be inspected and tested and a report on its condition obtained as prescribed in the Regulations for Electrical Installations published by the Institute of Electrical Engineers.

**Never allow modification of electrical systems or appliances except by qualified persons.**

**Outlet sockets located within the tourer should only be used with a dedicated appliance and not an independent unit.**

**No appliance shall be used outside when connected to an internal socket.**

**YOUR CARAVAN IS NOW SUPPLIED WITH 25 METRES OF MAINS CABLE TO COMPLY WITH BS EN1645.**

## FLEXIBLE WIRING

LIVE	BROWN
NEUTRAL	BLUE
EARTH	GREEN & YELLOW

## FIXED WIRING

LIVE	BROWN
NEUTRAL	BLUE
EARTH	GREEN & YELLOW



# SERVICES

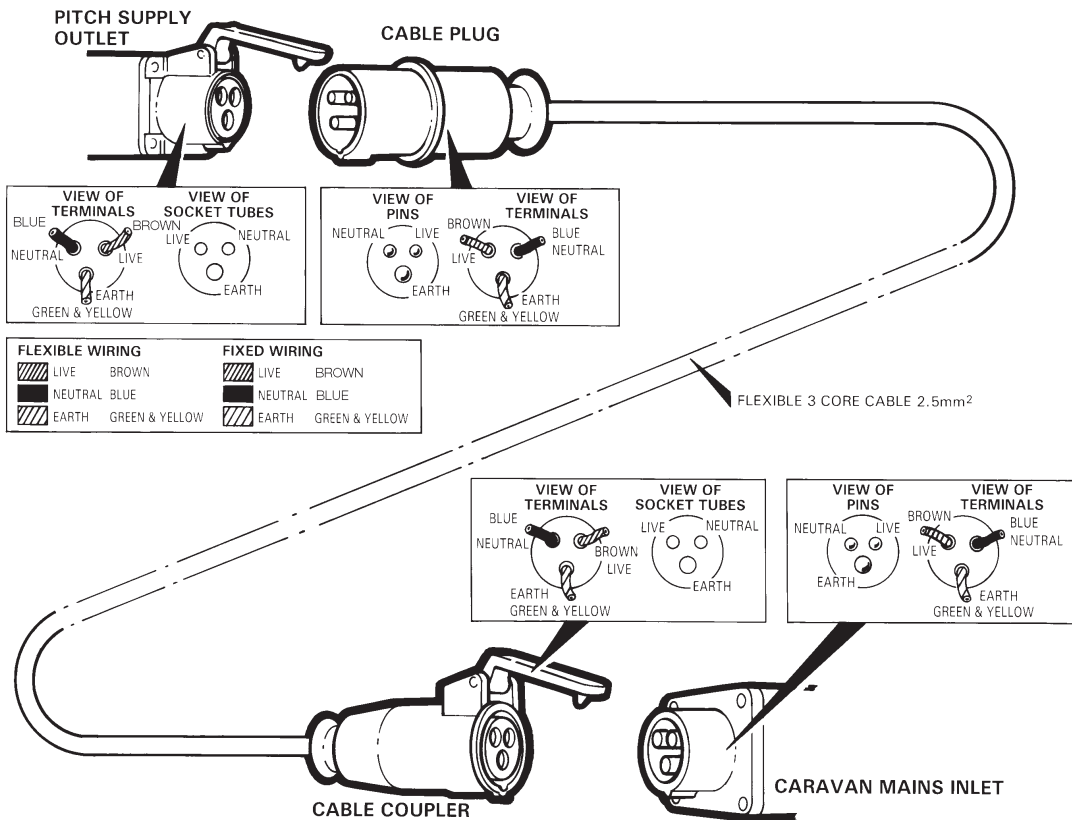

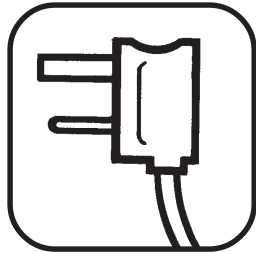

# **ELECTRICS**

Mains Power Units .....	46
Distribution Panel .....	47
Control Panel .....	48
Battery .....	49
Use of Generators .....	50



## ELECTRICS

### POWER DISTRIBUTION UNIT PDU

The PDU contains both the 230v ac equipment and the Power Supply to give 12 volts dc. This is capable of running the 12 volts system on its own or in conjunction with a leisure battery. It is however advisable to run with a battery in circuit.

Contained within the PDU are all the input and output circuit fuses. These are clearly identified and have the size of fuse clearly marked, this rating should not be exceeded.

#### 230volts ac

Containing the Earth leakage protection RCD (Residual Current Device) and the Overprotection current device MCB's (Miniature Circuit Breakers).

#### 12volt dc

Fully automatic power supply capable of running the 12 volt system up to 20 amps at 13.8 volts.

If a fault condition such as a short circuit or overload occurs, the power supply will automatically switch off until the fault is removed. This system is also capable of charging a totally flat lead acid, gel or AGM battery, however depending on its state this may take up to 48 hours. It is also recommended that you only use the power

supply in the PDU to charge your leisure battery.

#### Control system

Within the PDU relays control the system automatically when it chooses Car or Van Supply. When the Caravan is plugged into the Car then it will automatically switch to use the Car. However care should be taken when using power from the car battery, as this could drain the voltage of the car battery rendering insufficient voltage to start the car.

Continued use of a car battery to supply power to the caravan will in time cause damage to a car battery, and it is recommended to fit a leisure battery to the caravan.

When the Car ignition is switched on and the engine is started the interior supply to the Caravan 12 volt system will switch off (except alarm if fitted), and the supply to the fridge is connected. When the car engine is switched off the 12 volt power to the caravan is restored, however the 12-volt power to the fridge will be disconnected.

Ensure that the steps on page 43 "*Instructions for electricity supply*" are followed.

### OPERATION

Disconnect the electrical connector between the towing vehicle and the caravan before connecting an LV (low voltage) supply to the caravan and before charging the caravan battery by any other means.

Connect the 230 volt mains lead to the mains inlet fitted within the battery box, and then connect to the supply on the caravan site. Switch on the RCD and MCB's, at this point it is important to check the operation of the RCD and check the polarity of the site connection using a polarity tester. If the polarity is incorrect the site operators should be notified and rectified by a qualified electrician.

#### Specification

Power supply  
230 volt ac (+/- 10%)  
Output voltage 13.8 volts dc  
Output current 20 Amps  
Dimensions  
H 235mm W 375mm D 80mm

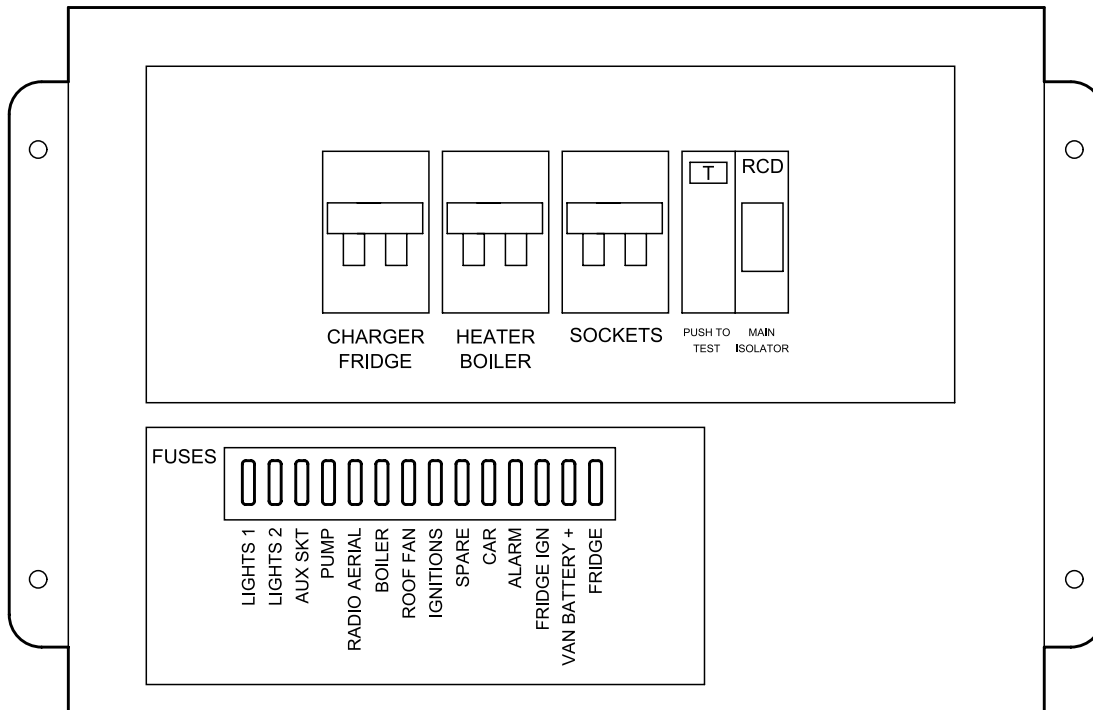

**Power Distribution Unit**



## ELECTRICS

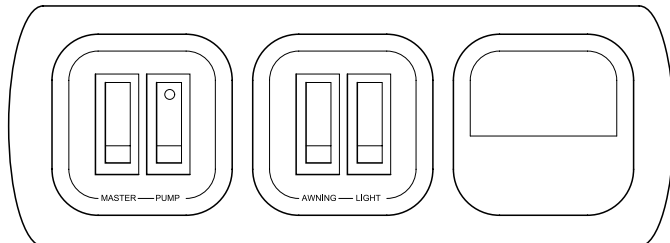

**Control Panel**

### Control Panel

All models feature a control panel governing the master switch, external water pump, awning light, internal lights and volt meter readings.

**Master switch.** Controls all the 12 volt supply to the caravan which is provided by the car/leisure battery or power supply, with the exception of the alarm, tracker, awning light and fridge ignition depending on fridge model.

**Pump switch.** Activates external pump. The light will illuminate when power is being provided to the pump.

**Awning switch.** Activates/deactivates the external awning light situated above the entrance door of the caravan. On models fitted with the Lunar Protector Caravan Alarm, if this switch is left in the on position then the awning light can be operated via the alarm remote handset.

**Light switch.** Activates/deactivates the interior central light closest to the entrance door, providing the power switch mounted on the central light is switched ON.





## GENERAL INFORMATION

### BATTERY

For optimum performance and safety it is essential that only a good quality CARAVAN battery is used. A normal car battery is NOT suitable.

#### WARNING

**One of the most common causes of caravan battery failure is for the battery to be discharged below the recommended level of approximately 10.5 Volts and therefore causing one or more cells to fail.**

Provided the appropriate relay is fitted to your car and the connection is made via the 13 pin plug and socket, a small trickle charge is achieved from car battery to the leisure battery when towing.

The auxiliary battery compartment is located on the offside of the caravan, with easy to fit and clearly identified positive and negative connectors.

It is recommended that a good quality leisure battery is always in circuit when the system is in use.

A heavy duty 12v battery should be purchased to provide power for lights and other electrical appliances. A proprietary

brand leisure battery with a 60, 90 or 110 amp capacity is recommended. (It must have tube venting capability for internal battery boxes).

It should be remembered that batteries suitable for the electrical demands of a caravan differ in design from those for use with a car, and whilst the system may operate with a car battery it is strongly recommended that only a caravan/leisure type battery, maintained in good condition is used. The battery should be kept topped up at all times.

The battery should be positioned in the designated vented compartment and properly secured. When connecting the battery, ensure that the correct polarity is observed (black is negative and red is positive) and that the terminals are securely fastened. (Crocodile clips are not recommended.)

Under normal circumstances it should not be necessary to remove the battery other than for routine inspection of terminals and "topping up".

The AC output of generators is often derived from an AC alternator, rectified to DC then inverted back to AC. In essence this means the output sinewave may not be very smooth and may not run sophisticated electronics

efficiently. Some of the new wave of gensets are more sophisticated in their production of a sinewave output and are more suited to run electronic equipment.

If in doubt consult your genset dealer or manufacturer for advice.

#### WARNING

**Explosive gases may be present at the battery. Take care to prevent flames and sparks in the vicinity.**

#### WARNING

**Switch off all appliances and lamps before disconnecting the battery.**



## ELECTRICS

---

### **GENERATOR GUIDELINES**

Lack of regular servicing can be the cause of most generator problems. Gensets under 2kW are mainly dependent on engine speed for output frequency and voltage, poor or no servicing may cause the engine speed governor to run the genset engine too fast. Therefore frequency and output voltage can rise above the specification of the machine data plate, i.e. 240v at 50Hz, This may cause damage to electrical/electronic equipment (such as battery chargers).

A generator should always be run for a few minutes prior to connection with the caravan electrics, to allow it to warm up and the output to settle to a steady level.

### **SUPPORT SERVICE**

Contact your local dealer.



# FITTED EQUIPMENT

- Truma Combi Boiler ..... 52
- Refrigerators ..... 54
  - Dometic RMS 8500 ..... 54
- Oven, Hob & Grill ..... 61
- Thetford C-260 CWE Toilet ..... 65
- Awning Points ..... 73
- Rooflight ..... 73
- TV Antenna ..... 73
- Wall Lights ..... 75
- Flyscreens/Blinds ..... 76
- Door Flyscreen ..... 76
- Body & Window Care ..... 77
- Condensation ..... 77
- Badges ..... 79



# TRUMA COMBI BOILER

**Note:** Most proprietary items within the caravan will have their own instruction book, the information within the Venus Handbook is an extract of the most relevant aspects.

## IMPORTANT

In the interest of safety, replacement parts for an appliance shall conform to the appliance manufacturer's specifications and should be fitted by him or an authorised agent.

To maximise the use and life of all fitted equipment in your caravan it is essential that any accompanying manufacturers' literature is read fully. All recommended maintenance and preparation procedures should be followed. The information provided in this handbook is only intended as a guide. If in any doubt consult your Venus appointed dealer, particularly before attempting to install EXTRA EQUIPMENT.

## TRUMA COMBI BOILER

### Introduction

The liquefied gas heater 'Truma Combi' is a warm air heater with an integrated hot water boiler (10 litre volume). The burner operates fan supported, which ensures trouble-free function even when on the move.

The heater can be used to heat the room and water at the same time or just heat hot water.

In warmer conditions the water contents are heated using the small burner. Once the

water temperature is reached, the burner switches off.

In winter or in lower temperatures the unit will automatically select the required power setting according to the temperature difference between the temperature set on the control panel and the current room temperature. When the boiler is filled, the water is automatically heated as well. The water temperature will depend upon the operational mode and the heater output.

If the heater is not to be used when freezing conditions are expected, the water system MUST be drained. NO warranty claim will be accepted for cases of frost damage.

Before using the heating system for the first time please ensure that the 12v system is turned ON at the control panel over the doorway and that the gas cylinder and isolation valve are turned on.

Fig. opposite shows the controls for the Truma Combi Boiler.

If the gas system is leaking or if there is a smell of gas:

- Extinguish all naked flames.
- Open all doors and windows.
- Close all quick-acting valves and gas cylinders.
- Do not smoke.
- Do not activate any electrical switches.
- Ask an expert to inspect the entire system.

Repairs may only be carried out by a certified repairer.

Any modifications to the unit, including the accessories, exhaust duct and cowl, or the use of spare parts and accessories that are important to the operation of the system that are not original Truma parts and failure to follow instructions will cancel any warranty and indemnify Truma of any liability claims.

It also becomes illegal to use the appliance, and in some countries this even makes it illegal to use the vehicle.

The gas supply's operation pressure (30 mbar) must be the same as the unit's operating pressure (see type plate).

The vehicle owner is always responsible for arranging periodic inspections.

Liquefied gas equipment may not be used when refuelling, in multi storey car parks, in garages or on ferries.

During the initial operation of a brand new appliance (or after it has not been used for some time), a slight amount of fumes and smell maybe noticed for a short while. It is a good idea to heat the device up several times and to make sure that the area is well ventilated.

Heat-sensitive items such as aerosols or flammable liquids may not be stored in the same compartment as the heater because this area may be subjected to high temperatures.



## TRUMA CONTROL PANEL

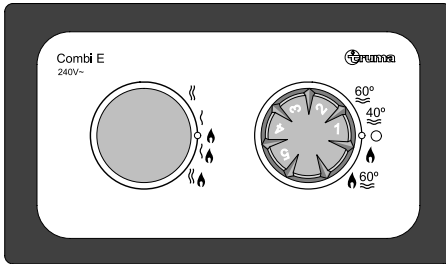

## Operating Information

### Power selector switch

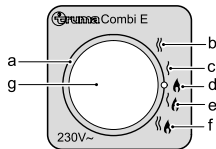

- a = Power selection rotary switch
- b = Electric operation 230V, 1800 W
- c = Electric operation 230V, 900W
- d = Gas operation
- e = Mixed operation\* (900W gas and electrical operation)
- f = Mixed operation\* (1800W gas and electrical operation)
- g = Yellow LED on = "Electrical operation"

\* Winter mode only!

In summer mode the unit automatically selects electric operation at the preselected electrical power of 900W or 1800W.

## Control panel

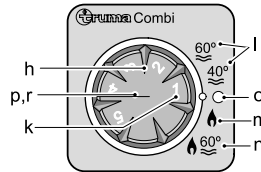

- h = Rotary switch for room temperature (1-5)
- k = green LED lit "Operation" green LED blinking "after-running" is active in order to reduce the unit's temperature
- l = Summer operation (water temperature 40°C or 60°C)
- m = Winter operation (heating without water temperature monitoring or with drained water system)
- n = Winter operation (heating with water temperature monitoring)
- o = Rotary "Off" switch
- p = Yellow LED lit = "Boiler heat-up phase"
- r = red LED lit, red LED blinking "Failure"

## Filling the Water Heater

- Check if the rotary switch for the drain valve is set to 'Operation', meaning that it is parallel to the water connection and engaged.
- Close the drain valve by pushing the push button until it engages.
- Switch on power for water pump .
- Open hot water taps in kitchen and bathroom. Leave the fittings open for as long as it takes for the boiler to displace the air and fill up, and the water to flow without interruption.

For more detailed information on operating the Truma Combi boiler please refer to TRUMA appliance instructions that can be found in your information wallet.

**It is essential that you do not block/ obstruct or cover the flue outlet from your Truma Combi Boiler.**



# REFRIGERATOR

## REFRIGERATORS

### Winter Operation - Dometic Refrigerators



- ▲ Please check that the ventilation grilles or the flue outlets are not blocked by snow, leaves etc.

### DOMETIC REFRIGERATOR MODEL RMS 8500

#### Cleaning

Before starting up the refrigerator, it is recommended to clean it inside and repeat this at regular intervals. Use a soft cloth and lukewarm water with a mild detergent. Then wipe out the appliance with clean water and dry thoroughly.



- ▲ To avoid deterioration of materials: Do not use soap or hard, abrasive or soda-based cleaning agents. Do not allow the door seal to come into contact with oil or grease.

#### Operating modes and use of the refrigerator

- This refrigerator is equipped to operate on three power modes: AC mains power (230V), 12V DC or gas (propane/butane liquid gas).

- Select the desired power mode by the energy selector switch (battery igniter type models) or the MODE button (MES, AES). Appliances with automatic energy selection (AES) are additionally provided with automatic mode function. The AES system automatically selects the best energy source for each particular situation.
- The cooling unit is silent in operation.
- The refrigerator works reliably on slopes of up to 6 degrees (5 degrees with models starting from 140 litres capacity).
- When the appliance is started for the first time, there may be a mild odour which will disappear after a few hours. Air the living space thoroughly.
- The refrigerator will take several hours to reach its operating temperature in the cooling compartment.

### Control elements of energy selections (BATTERY IGNITER, MES and AES)

Manual energy selection/manual ignition (RM 8500) battery igniter:

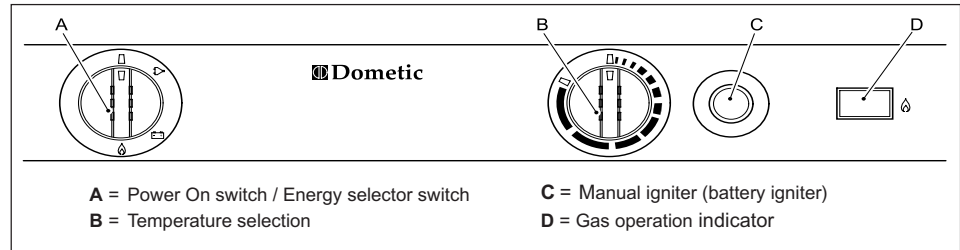

# REFRIGERATOR



## Explanation:

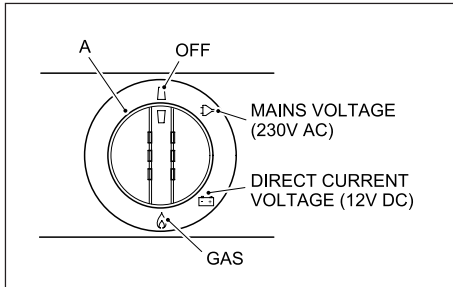

The refrigerator is equipped to operate on mains power, 12V DC or liquid gas. Select the desired power supply by turning the energy selector switch A. The energy selector switch A has four settings: OFF, AC mains voltage, DC (battery), gas (liquid gas).



## Electrical operation

Appliances with battery igniter (manual energy selection)

Switch on the appliance by turning the energy selection switch A clockwise to position:

-  230V operation,
-  12V operation

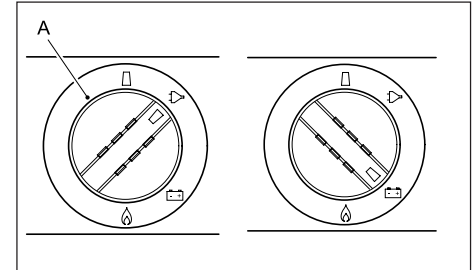

- In order to prevent discharge of the on-board battery, 12V operation should only be used while the motor is running.

## Gas operation (liquid gas)



- ▲ The refrigerator must be operated using liquid gas (propane, butane (no natural gas or town gas). When using LPG gas, please consider that the burner needs cleaning at shorter intervals due to the gas combustion method (semi-annual recommended).
- ▲ In Europe, gas operation is permitted while travelling only on the condition that the gas system of the vehicle is equipped with a hose rupture protection. The national regulations of the respective country must be observed.
- ▲ For physical reasons, ignition faults could occur starting from an altitude above sea level of approx. 1000m/3280 ft. (No malfunction!)
- ▲ On the initial refrigerator start-up or after a cylinder change, air may be trapped in the gas line. To purge the air from the lines, switch on the refrigerator and any other gas appliances (e.g. stove) for a short time. The gas ignites without delay.
- ▲ As a basic rule, gas operation is prohibited in petrol stations.



# REFRIGERATOR

**Prior to starting the refrigerator in gas mode:**

- Open the gas cylinder valve.
- Open the shut-off valve for gas supply to the refrigerator.

**Appliances with battery igniter:**

1. Turn the rotary selector switch **A** to position .
2. Turn the temperature selector **B** clockwise and push. Keep the controller button depressed.
3. Then, press knob C of battery igniter down and keep it depressed. The ignition process is activated automatically.
4. Once the flame ignites, the pointer of galvanometer **D** begins moving into the green range. The refrigerator is operational. Keep knob **B** depressed for approx. 15 seconds and finally release it.

**Each refrigerator with manual ignition is equipped with an automatic flame safety valve which interrupts the gas supply after approx. 30 seconds when the flame has extinguished.**

## Door Locking

Open the door by pressing the locking button and pull open.

Shut the door again by pushing it to close. The snapping into the lock can be heard.

While the vehicle is parked, the locking hook can be fixed to facilitate opening of the door.

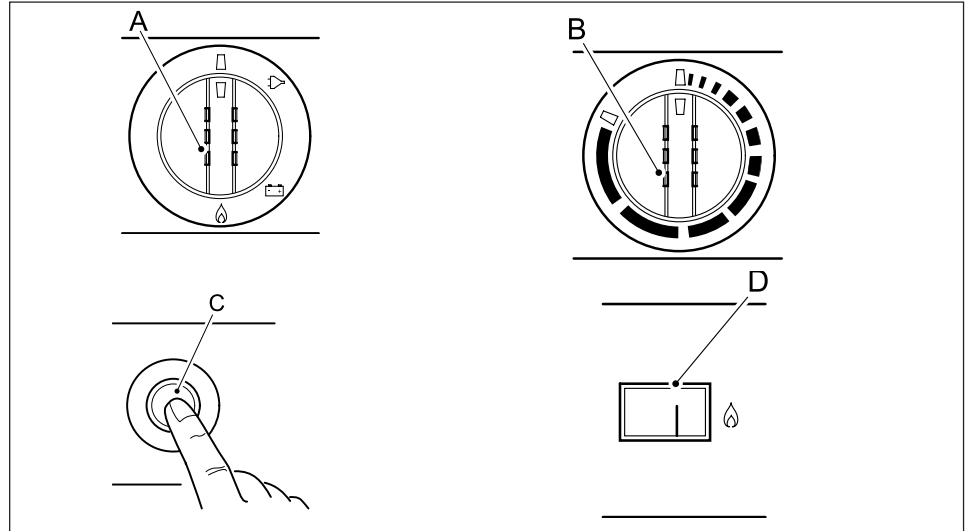





## Fixing and releasing the door lock hook when parking the vehicle

If the vehicle is parked for a longer period of time, the locking hook may be clamped by means of a lockbar. The door may now be opened by just pulling it without need of pressing the locking button.

Restore the original position by pushing the hook down.



- ▲ As a basic rule, shut and lock the refrigerator door before commencing your journey.

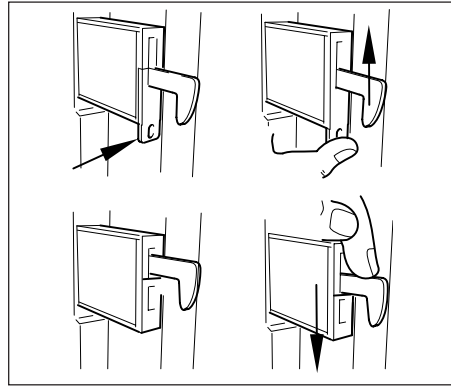

## Removable freezer compartment

To enlarge the cooling space, just remove the freezer compartment.

Unlock the freezer compartment on both sides and pull it out.

Store the freezer compartment safely in order to prevent damage.

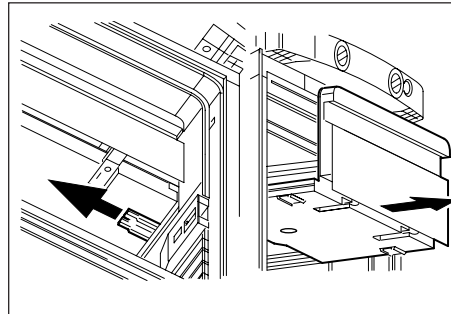

## Positioning the storage racks

The storage racks may be pulled out by smoothly lifting them and may be positioned as desired.

- ▲ Once the freezer compartment is removed, an additional storage rack may be installed. The storage rack is a piece of extra equipment and may be obtained from Dometic.

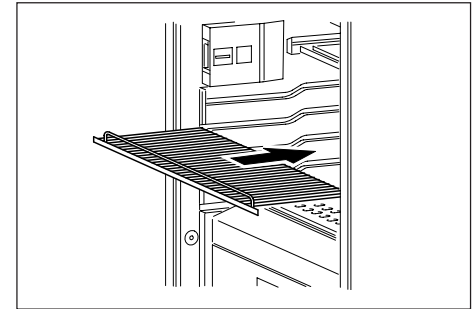



# REFRIGERATOR

## Exchange of the igniter's battery

Unlock the battery by depressing and turning the button (C) approximately 90 degrees clockwise.

Remove cap and exchange battery (1.5V AAA / R3 / Micro). Observe correct polarity.

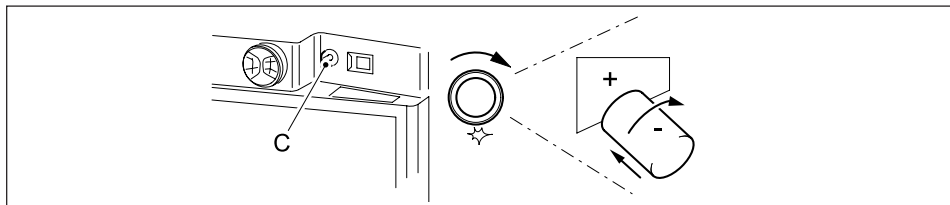

## Shutting off the refrigerator

- For battery igniter models, set energy selector switch **A** to position 'OFF'. The appliance is switched off.
- Press the 'MODE' button to switch off MES and AES models. Keep button **A** pressed for two seconds. The display disappears and the appliance is fully switched off.
- Release the locking mechanism of the door lock by pushing it and shift it to the front. If the door is shut in this position, a small gap is nevertheless kept open to prevent formation of mildew.
- If the refrigerator is to be taken out of service for an extended period of time, close the onboard shut-off valve and the cylinder valve.

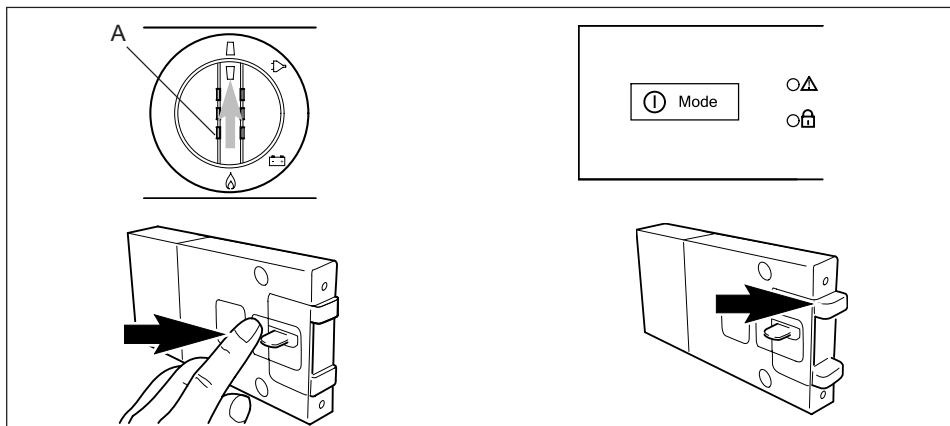

## Lighting

If the door is open for more than two minutes, the sensor-controlled interior lighting is automatically cut off (except for models with battery igniter).

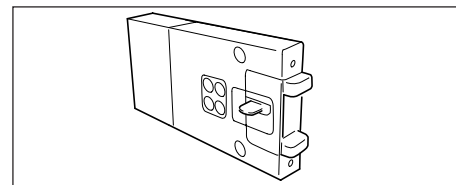



## Troubleshooting

Before notifying the authorised Service Centre, please check whether:

- ▲ The instructions in the section “Operating the refrigerator” have been followed.
- ▲ The refrigerator is level.
- ▲ It is possible to operate the refrigerator with any available power source.

### **Failure: The refrigerator does not cool sufficiently.**

#### *Possible cause*

- a) Inadequate ventilation to the unit.
- b) Thermostat setting is too low.
- c) The condenser is heavily frosted.
- d) Too much warm food has been stored inside within short period of time.
- e) The appliance has been running for only a short period of time.
- f) Ambient temperatures too high.

#### *Action you can take*

- a) Check that the ventilation grilles are not covered.
- b) Set thermostat to a higher level.
- c) Check that the refrigerator door closes properly.
- d) Allow warm food to cool down before storage.
- e) Check whether the cooling compartment works after approximately 4-5 hours.
- f) Regularly remove ventilation grilles.

### **Failure: The refrigerator does not cool in gas operation mode.**

#### *Possible cause*

- a) Gas cylinder empty.
- b) Is the supply shut-off device open?
- c) Air in the gas pipe?

#### *Action you can take*

- a) Change gas cylinder..
- b) Open the shut-off device.
- c) Switch off the appliance and start again. Repeat this procedure 3-4 times, if necessary.



# REFRIGERATOR

---

## **Failure: The refrigerator does not cool in 12V operation.**

### *Possible cause*

- a) On-board fuse defective.
- b) On-board battery discharged.
- c) Engine not running.
- d) Heating element defective (please also refer to failure indication).

### *Action you can take*

- a) Fit new fuse.
- b) Check battery, charge it.
- c) Start engine.
- d) Please inform the Dometic Customer Services.

## **Failure: The refrigerator does not cool in 230V operation.**

### *Possible cause*

- a) On-board fuse defective.
- b) No connection to supply voltage.
- c) AES: gas operation despite connection to the supply voltage?
- d) Heating element defective (please also refer to failure indication).

### *Action you can take*

- a) Fit new fuse.
- b) Establish power connection.
- c) Appliance switches to gas operation due to insufficient supply voltage (automatically switches back to 230V operation).
- d) Please inform Dometic Customer Services.

## **Maintenance**

- Works on gas components and electrical installation may only be carried out by authorised personnel. We recommend to contact your Dometic Service Centre.
- EN 1949 stipulates that the appliance's gas equipment and its associated fume system must be inspected after installation and a certificate issued.
- Afterwards a qualified technician must inspect according to EN 1949 every two years and a certificate issued.



## SPINFLO DUPLEX COMBI OVEN

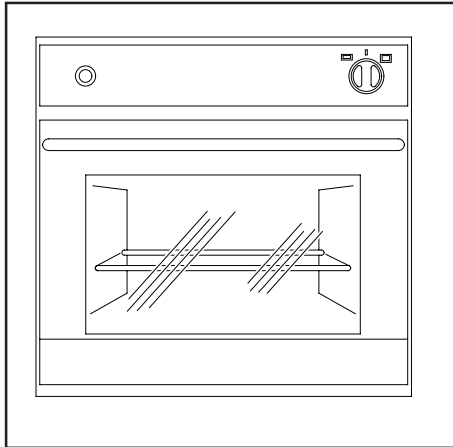

### Using the Grill

- (1) Ensure gas supply is connected and turned on.
- (2) Open door, push in the control knob and turn clockwise to full rate - large flame ( ).
- (3) Light burner with match, keeping the control knob held in for 10 - 15 seconds - models with Spark Ignition the procedure is similar except burner ignited by depressing the ignition button.
- (4) Release knob and turn to required heat setting.

- (5) If burner has not lit within 15 seconds, release knob and wait at least 1 minute before repeating operations (2) to (4).
- (6) To turn off, rotate the control knob until the line on the knob is aligned with dot on the control panel.
  - The pan supplied with the appliance is multi-functional, for use either whilst grilling or when using the oven.
  - The pan handle can be removed or inserted whilst pan is in use. Always remove the handle when the pan is in use.
  - The control tap on this appliance operates both the Grill and Oven burners. To ensure safe operation it is not possible to operate both burners at the same time.

### WARNINGS

- **The grill MUST only be used with the grill door open.**
- **The heat deflector below the fascia should be pulled out prior to lighting the grill. Never adjust the heat deflector position without using hand protection - ie oven gloves.**
- **When cooking always ensure young children are kept away.**

### Using the Oven

- (1) Ensure gas supply is connected and turned on.
- (2) Open door, push in the control knob and turn anti-clockwise to gas mark 9.
- (3) Light burner with match, keeping the control knob held in for 10 - 15 seconds - for models with spark ignition the procedure is similar except burner ignited by depressing the ignition button.
- (4) Release knob and turn to required heat setting.
- (5) If burner has not lit within 15 seconds, release knob and wait at least 1 minute before repeating operations (2) to (4).
- (6) Place the oven shelf in the required position and close the door.
- (7) To turn off, rotate the control knob until the line on the knob is aligned with the dot on the control panel.

Before first time use, heat the oven at gas mark 5 for 30 minutes to eliminate any residual factory lubricants, open windows to assist in removal of any unpleasant smells or smoke.

Although the oven does heat up quickly, it is recommended that a 10 minutes preheat be allowed. The oven should reach full temperature in 15 - 20 minutes.



## OVEN, HOB & GRILL

The shelf has a raised bar to prevent dishes making contact with the back of the oven and to allow good circulation at the rear of the oven. To remove a shelf, pull forward until it stops, raise at front and remove.

### Oven Temperature Control

The oven temperature is controlled by a thermostatic gas tap and is variable over the range 130°C to 240°C. The temperature settings on the control knob refer to the centre of the oven and at any particular setting the oven will be hotter at the top and cooler towards the base. The variation between top and centre, and centre to bottom is approximately equivalent to one gas mark. Care should be taken not to overload the oven, ensure adequate spacing when cooking more than one item to allow free circulation of heat.

### WARNING

**Never cover slots or holes in the oven or cover a shelf with materials such as aluminium foil. Doing so restricts airflow and may cause carbon monoxide poisoning.**

### DO'S AND DON'TS

**DO** read the user instructions carefully before using the appliance for the first time.

**DO** allow the oven to heat before using for the first time, in order to expel any smells before the introduction of food.

**DO** clean the appliance regularly.

**DO** remove any spills as soon as they occur.

**DO** use oven gloves when removing food shelves and trays from a hot oven.

**DO** check the controls are in the off position when finished.

**DO NOT** allow children near the cooker when in use. Turn pan handles away from the front so that they cannot be caught accidentally.

**DO NOT** allow fats or oils to build up in the oven trays or base.

**DO NOT** use abrasive cleaners or powders that will scratch the surface of the appliance.

**DO NOT** under any circumstances use the oven as a space heater.

**DO NOT** put heavy objects into open grill and oven doors.

### LEAKS

If a smell of gas becomes apparent, the supply should be turned off at the cylinder **immediately**.

Extinguish naked lights including cigarettes and pipes. Do not operate electrical switches. Open all doors and windows to disperse gas escapes.

Butane/Propane gas is heavier than air and escaping gas will collect at a low level. The strong unpleasant smell of gas will enable the general area of the leak to be detected. Check that the gas is not escaping from an unlighted appliance.

Never check for leaks with a naked flame; leak investigation should be carried out using a leak detector spray.

### MAINTENANCE

This appliance needs little maintenance other than cleaning. All parts should be cleaned using warm soapy water. Do not use abrasive cleaners, steel wool or cleansing powders. When cleaning the burner ring it is essential that the holes do not become blocked. The control knobs are a push fit and can be removed for cleaning.



## Theftord 3 Burner Hob

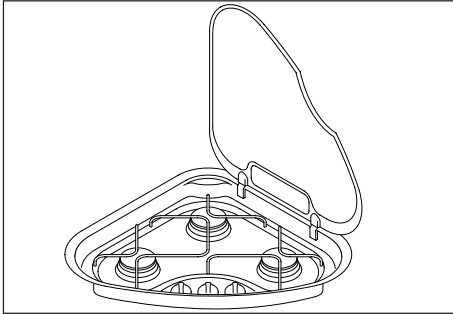

This appliance is designed for cooking food, any other use is incorrect and dangerous. Failure to install the appliance correctly or improper use could invalidate any warranty or liability claims and lead to prosecution.

### Ventilation

The use of a gas cooking appliance results in a production of heat and moisture in a room in which it is installed. Ensure that the kitchen is well ventilated. Keep natural ventilation holes open or install a mechanical ventilation device, (mechanical extractor hood).

Prolonged intensive use of the appliance may call for additional ventilation, for example opening a window.

The appliance must be positioned free from

draughts, which may affect the combustion in a manner that will prevent the accumulation of unburnt gas. When in use ensure that air vents are not inadvertently blocked or shut off.

### Burner Operation

The burners on the appliance have fixed aeration and no adjustment is required. The burners should flame as follows:

**Propane** - The flames should burn quietly with a blue/green colour with no sign of yellow tips.

**Butane** - Normally on initial lighting, a small amount of yellow tipping will occur and then slightly increases as the burner heats up.

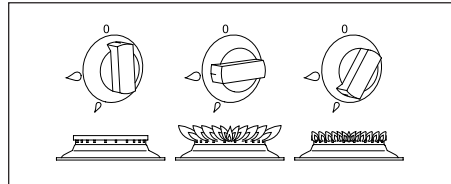

### IMPORTANT

- **Series 330** - will support 200mm Ø pans on the outer burners and 180mm Ø pan on the central burner.
- **Avoid old or misshapen pans as these may cause instability.**
- **The lid must be opened fully prior to using the hotplate burners.**

1. Ensure gas cylinder/supply is connected and turned on. In the event of a gas smell turn off at gas cylinder/mains and contact supplier.
2. Flame supervision: Each burner is controlled individually and is monitored by a thermocouple probe. In the event of the burner flames being accidentally extinguished, turn off the burner control and do not attempt to re-ignite the burner for at least one minute.
3. To light: Push in the control knob and turn to full rate. Hold a lighted match or taper to the burner and push the control knob in and hold. It is necessary to hold the knob depressed after the burner has ignited for approximately 10 - 15 seconds, to allow the thermocouple probe to reach temperature, before releasing the knob. Should the flame go out when the knob is released, the procedure should be repeated holding the knob depressed for slightly longer.
4. For models fitted with optional Spark Ignition the procedure is similar:

**Models with Auto Spark Ignition** - pushing the control knob automatically starts the spark ignition circuit. To light the burner follow the procedure in (3) above, except that the burner can be ignited by depressing the ignition button located on the fascia.



## OVEN, HOB & GRILL

**Models with Manual Spark Ignition** - follow the procedure in (3) above, except that the burner can be ignited by depressing the ignition button located on the fascia.

If the burner has not lit within 15 seconds the control knob should be released and the burner left for at least 1 minute before a further attempt to ignite the burner.

5. For simmering, turn the knob further anti-clockwise to the low rate position.
6. To turn off: Turn the control knob until the line on the control knob is aligned with the dot on the control panel. Always make sure the control knob is in the off position when you have finished using the hotplate burners.

### WARNING

**The Glass lid has the tendency to snap shut towards the end of lowering. This is caused by the travel lock action of the hinges as it is activated. Make sure all fingers are removed from appliance when closing the lid.**

### DO'S AND DON'TS

**DO** read the user instructions carefully before using the appliance for the first time.

**DO** allow burners to heat before using for the first time, in order to expel any smells before the introduction of food.

**DO** clean the appliance regularly.

**DO** remove spills as soon as they occur.

**DO** check that controls are in the off position when finished.

**DO NOT** allow children near the appliance when in use. Turn pan handles away from the front so that they cannot be caught accidentally.

**DO NOT** allow fats or oils to build up in the base of the hotplate.

**DO NOT** use abrasive cleaners or powders that will scratch the surfaces of the hotplate.

**DO NOT** under any circumstances use the appliance as a space heater.

### LEAKS

If a smell of gas becomes apparent, the supply should be turned off at the cylinder **immediately**.

Extinguish naked lights including cigarettes and pipes. Do not operate electrical switches. Open all doors and windows to disperse any gas escape. Butane/Propane gas is heavier than air, any gas escaping will therefore collect at low level. The strong unpleasant smell of gas will enable the general area of the leak to be detected. Check that the gas is not escaping from an unlit appliance. Never check for leaks with a naked flame; leak investigation should be carried out using a leak detector spray or soapy solution.





## THETFORD C-260 CWE CASSETTE TOILET

### INTRODUCTION

The Thetford Cassette Toilet is a high quality product. The toilet forms an integral part of your caravan or camper bathroom, thanks to its functional design which combines modern styling and ease of use. The C-260 Cassette Toilet is manufactured from high quality synthetic materials which makes it a durable, user and maintenance friendly toilet.

The toilet is made up of two parts: a permanently fixed part and a Waste Holding Tank that is accessible from the outside. The removable Waste Holding Tank is located under the toilet bowl and can be removed via a door on the outside of the caravan or camper. The Thetford Cassette Toilet is the solution to the sanitary problem in your caravan or camper!

The operating instructions cover Thetford Cassette Toilet models C-260S, C-260CS (models connected to the vehicle's central water tank) and C-260CWE (model with its own flush-water tank). There are differences in the use of these models. Please ensure that you follow the instructions that apply to your toilet model.

Standard C-260

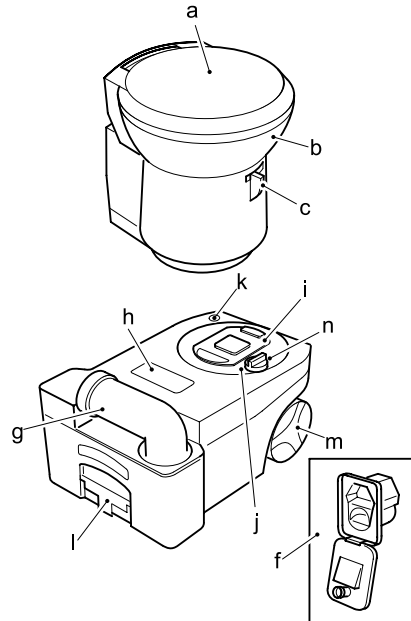

Optional features C-260

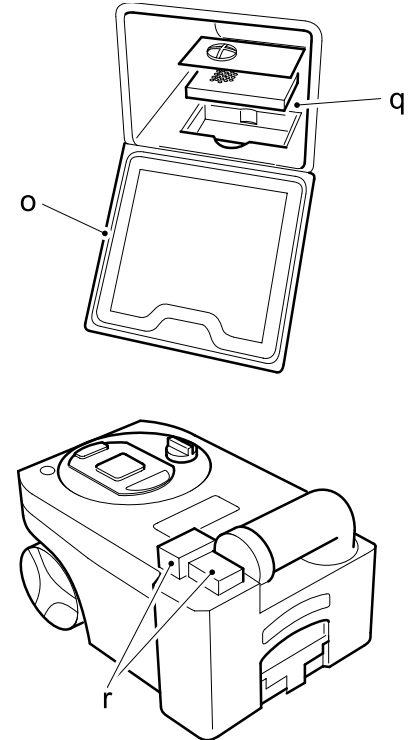



# THETFORD TOILETS

Control panel (with optional features)

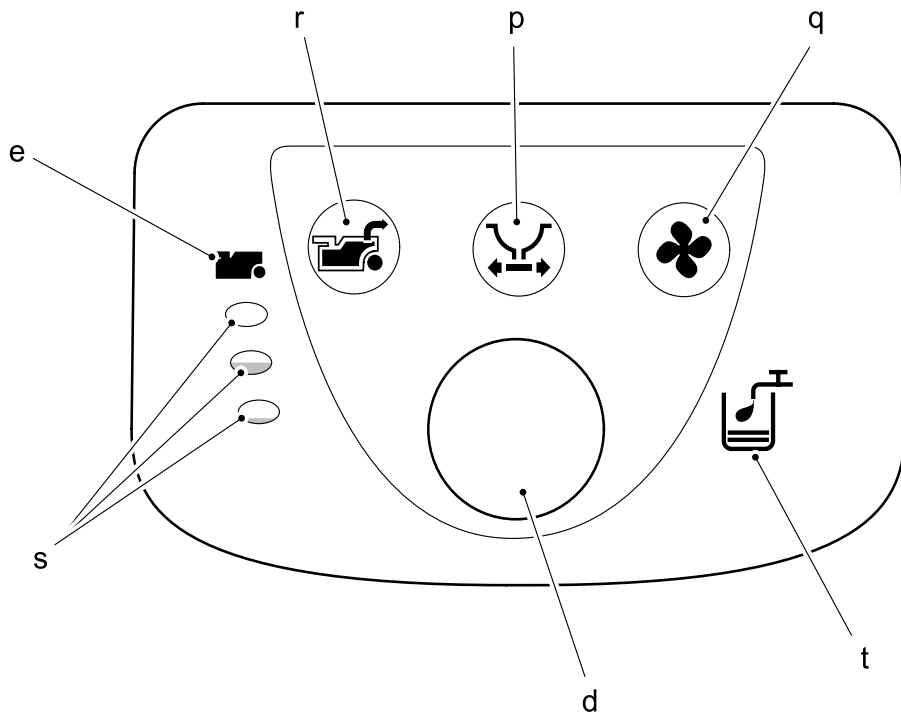

## PARTS

- a) Removable Seat and Lid
- b) Swivelling Toilet Bowl
- c) Blade Handle
- d) Flush Button
- e) Waste Holding Tank Level Indicator
- f) Water Filling Door (only if toilet has own flush-water tank)
- g) Rotating Emptying Spout
- h) Automatic Pressure Release Vent
- i) Sliding Cover
- j) Removable Mechanism
- k) Vent Plunger
- l) Pull-out Handle
- m) Wheels
- n) Blade Opener
  
- o) Access Door to Waste Holding Tank

## Optional Features

- p) Electric Blade
- q) Automatic Ventilator
- r) Waste Pump-Out System
- s) Waste Holding Tank Multi-Level Indicator
- t) Flush-Water Tank Level Indicator (only if toilet has its own flush-water tank)

**Note:** Optional features can be bought from Thetford dealerships.



## Preparing for use (standard)

1. Open the access door on the outside of your caravan or camper.
2. Remove the Waste Holding Tank by pulling the safety catch (which holds the tank in place) upwards.
3. Pull the Waste Holding Tank outward to the stop. Tip it slightly and take the tank fully out.
4. Place the tank upright and turn the rotating emptying spout upwards. The emptying spout ensures that the tank can be easily and hygienically emptied.
5. Remove the cap, with the measuring cup inside, from the emptying spout and pour the correct dosage of Thetford toilet fluid (see product label) into the holding tank. This avoids unpleasant smells and keeps the inside of the tank clean. Next add approximately 2 litres of water - enough to ensure that the bottom of the Waste Holding Tank is covered. For more information on Thetford toilet fluids, see last page of this manual. Screw the cap back onto the emptying spout and turn back to its original position.

**Note:** The Emptying Spout Measuring Cap is supplied in the same packaging as this manual.

**WARNING:** Never add toilet fluid directly via the blade or the toilet bowl as this

could damage the lip seal of the Waste Holding Tank. Always pour the fluids via the emptying spout.

6. Slide the Waste Holding Tank back into its original position via the access door. Make sure that it is secured with the safety catch. Close the access door and lock it. Your Thetford toilet is now ready to use.

**WARNING:** Never use force if you cannot get the tank back into place easily. This may cause serious damage. If blockage occurs, always check if the blade handle is in the correct (closed) position.

7. For toilets with own Flush-Water Tank: Open the water filling door and fill the flush-water tank with the correct dosage of Aqua Rinse. This Thetford toilet fluid keeps the flush water fresh and improves the flushing. Next, fill up the flush-water tank with clean water (approximately 8 litres) using a ferry can or hose. Your toilet is now ready to use.

## Preparing for use with Optional Features

8. Automatic Ventilator: Open the access door on the outside of your caravan and remove the Waste Holding Tank (as described above).
9. Remove the filter housing cover and if no filter is present, place a new filter into the filter housing. Peel off the sticker lids on the filter. Place back the cover of the filter housing.

## Using the toilet (standard)

10. Turn the bowl to the desired position with the lid closed and using both hands.
11. To activate the control panel, press the flush-button once. The control panel display will stay activated for approximately 5 minutes. Run some water into the bowl by pressing the flush button again briefly.
12. The toilet may be used with the blade open or closed. To open the blade, slide the blade handle under the toilet bowl sideways. After use, open the blade (if still closed) and flush the toilet by pressing the flush button for several seconds (if necessary re-activate the control panel). Close the blade after use.

**WARNING:** If your toilet has its own flush-water tank, please make sure that



## THETFORD TOILETS

**you do not travel with a flush-water tank that is too full. Do not travel with water in the toilet bowl. Failure to adhere to this notice may result in water damage to your caravan or motor home.**

### Using the toilet with Optional Features

- 13. Electric Blade:** Push the electric blade button on the control display to electrically open or close the blade. In the case of failure, you can manually open or close the blade by sliding the small handle under the toilet bowl sideways.
- 14. Automatic Ventilator:** The ventilator automatically starts when the control panel is activated (by pressing the flush button) and will automatically shut off after approximately 5 minutes. The Automatic Ventilator Indicator will flash until automatic shut-off occurs. If you want to stop the ventilator, press the Automatic Ventilator button. If you want to re-start the ventilator, press the button again (the LED will start flashing again).
- 15. Flush Water Tank Level Indicator** (only for toilets with own flush-water tank): When the Flush Water Tank Level Indicator lights up, refill the flush-water tank, as only about 1.5 litres of water is left in the tank, which is sufficient for approximately 2 flushes.

### Emptying

The Waste Holding Tank has a capacity of 18 litres and requires emptying when the red light (LED) on the toilet control display lights up, when the Waste Holding Tank only has capacity for approximately 2 more litres, which is no more than two to three further uses.

Make sure that the blade is closed. Open the access door located outside the vehicle, pull the safety catch upwards and remove the Waste Holding Tank.

- 16.** Place the Waste Holding Tank in an upright position (Pull-Out Handle at the top, Wheels at the bottom). Slide the handle sideways - to the front of the tank - until it snaps out of its locked position.
- 17.** Pull the handle up and wheel the Waste Holding Tank to an authorized waste disposal point.
- 18.** Push the handle back into its locked position. Turn the emptying spout upwards and remove the cap from the spout. Hold the Waste Holding Tank in such a way that during emptying you can operate the vent plunger with your thumb. To empty the tank without splashing, depress the vent plunger while emptying the tank. After emptying, rinse the tank and blade thoroughly with water.

**WARNING: Do not seriously shake the tank or use high pressure water cleaners. This may cause damage to the tank's interior.**

**Note:** The vent plunger should only be depressed once the emptying spout is pointing downwards. Prepare the toilet for re-use if required. Slide the Waste Holding Tank into the toilet and close the access door.

### Emptying with Optional Features

- 19. Waste Holding Tank Multi-Level Indicator:**  
The lower lamp indicates that the Waste Holding Tank is almost empty; the middle lamp indicates that it is more than half full; when the upper lamp lights up, the tank needs emptying as it can only take 2 - 3 further uses.  
**Note:** The Waste Holding Tank Level Indicator will flash when the holding tank is not present. In this case the toilet will not flush.
- 20. Waste Pump-Out System:** When activating the control panel this feature automatically lights up. When the Waste Holding Tank Level Indicator illuminates, press the Waste Pump-Out button to pump out the waste from the holding tank into the vehicle's waste tank. The button will flash while the waste is being



pumped and will stop automatically (after approximately 5 minutes) when all waste has been transferred. If the vehicle's waste tank is full, the Waste Pump-Out light will flash rapidly and no pump-out will be possible until the central tank is emptied. (Check the level of the vehicle's waste tank on the vehicle's central console). After the Waste Holding Tank has been emptied, there will be approximately 1.5 litres of waste left in the tank. This is normal. Add 2 litres of water and a correct dosage of Thetford toilet fluids to the Waste Holding Tank.

**CAUTION: It is vital that the correct amount of toilet fluid is added to ensure the proper breakdown of the waste in the holding tank. Only use the system when the tank is full. Using the system too often on an empty tank can cause damage to the pump, which could cause the system to fail.**

## CLEANING AND MAINTENANCE

The toilet should be cleaned and maintained regularly, depending on the amount of use. To clean Thetford toilets, we advise using water and Thetford Bathroom Cleaner.

**Note:** Never use bleach, vinegar or other powerful household cleaners that contain these substances. These may cause permanent damage to the seals and other toilet components.

### Toilet Bowl

- Squirt Thetford Bathroom Cleaner into the toilet bowl.
- Flush the toilet bowl with water and wipe down the rest of the toilet with a damp cloth.
- Clean seat and lid The seat and lid can easily be removed: Lift the seat and lid assembly and pull the round pins (inside the assembly) outwards from the pin holes. After cleaning, replace the seat and lid by positioning the round pins in front of the pin holes and push the lid and seat downwards.
- To keep your flush water fresh and to prevent deposits from forming in your toilet bowl, add a correct dosage of Aqua Rinse in your flush water tank, if present, on your toilet.

**Tip!** For a really shining toilet, dry with a soft dry cloth after cleaning.

## Waste Holding Tank

To keep your Waste Holding Tank fresh and clean, Thetford has developed a number of different toilet fluids. Thetford toilet fluids suppress smells, reduce formation of gas, promote breakdown of toilet waste and increase the life span of a mobile toilet. We advise a thorough cleaning of the Waste Holding Tank once each season. Next to using Thetford's Cassette Tank Cleaner, the powerful cleaning agent for the periodical cleaning of the Waste Holding Tank of your toilet, we suggest the following: -

- Remove the removable mechanism from the Waste Holding Tank by turning it anti-clockwise and rinse it under a tap.
- Remove the cover plate from the Automatic Pressure Release Vent by prising it up using a small screwdriver. Use one hand to push the Automatic Pressure Release Vent open while holding the float of the Automatic Pressure Release Vent on the inside of the tank with the other hand. Push the float upwards, turn it 180 degrees and remove it from below. Remove the rubber seal underneath the float. Rinse the float and rubber seal under a tap. Replace the rubber seal and float for the Automatic Pressure Release Vent using the same method in reverse.



# THETFORD TOILETS

The rubber seals in the toilet (the lip seal, the mechanism seal, the automatic pressure release vent seal and the cap seal) should be regularly cleaned with water and treated with Thetford High Grade Seal Lubricant. This will ensure that the seals remain flexible and in good condition. If the toilet is not to be used for any length of time, it is important to treat the seals with Thetford High Grade Seal Lubricant after cleaning.

**Note:** Never use Vaseline or any vegetable oil except olive oil. These may cause leakage or malfunction. The lip seal is a part of the toilet that is subject to wear. Depending upon the extent and manner of use, the seals will become less effective and will need replacing periodically.

## Cleaning and Maintenance for Optional Features

- **Automatic Ventilation:** The filter of the Automatic Ventilation needs to be renewed periodically. After approximately 4 full weeks of use, the filter loses its absorption power.
- **Pump-Out Waste System:** To ensure optimal functionality of the Pump-Out Waste System, periodical maintenance of the tube and pump is recommended. After emptying the Waste Holding Tank completely, fill it with clean water and empty it again. This will clean the pump

and the hose. Do this once every 3 weeks when on holiday. This should ensure proper operation of the system.

## Winter operation

You can use your Thetford Cassette Toilet as normal in cold weather as long as the toilet is situated in a heated location. If there is a risk of freezing we advise that the toilet is drained by following the instructions under 'Storage'. For environmental reasons the use of antifreeze, such as that used in car radiators, is not recommended.

## Storage

It is important that you follow the instructions below if you do not expect to use your Thetford toilet for a long (winter) period.

- Activate the Control Panel by pressing the flush button. Open the blade and press the flush button until water stops flowing into the bowl. Close the blade. Open the access door on the outside of your caravan or camper and empty the Waste Holding Tank at an authorized waste dump. Follow the instructions for cleaning and maintenance. To allow the Waste Holding Tank to dry, do not place the cap back on the emptying spout of the tank.
21. If the toilet has its own flush-water tank, place a sufficiently large bowl under the

drain tube to catch the remaining water from the flush-water tank and remove the drain plug. When no more water exits, put the drain plug on the drain tube, put it back in its original position and close the access door. If the toilet is connected to the vehicle's water tank, please follow your vehicle's instructions for draining the central water system. If your toilet is optionally featured with a Waste Pump-Out System, take out the Waste Holding Tank and completely clean it (see Cleaning and Maintenance). After cleaning, fill it with water, put it back and empty it via the waste pump-out system. Repeat this twice.

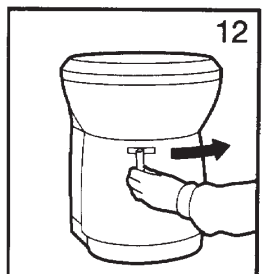
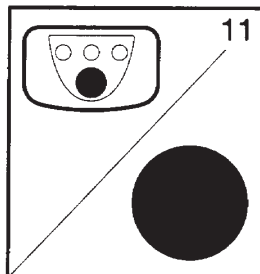
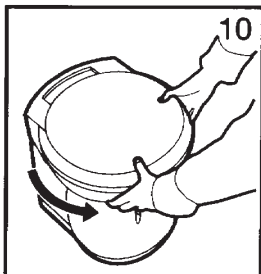
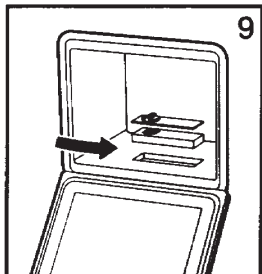
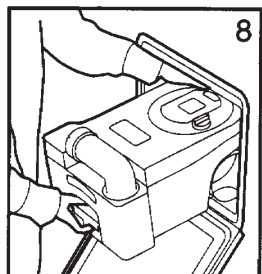
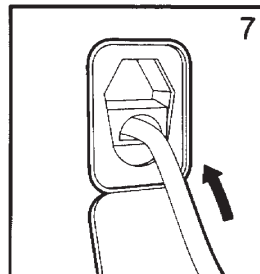
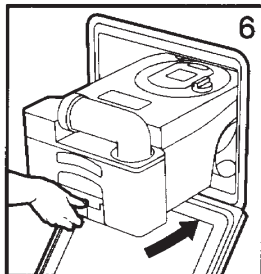
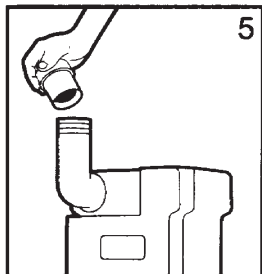
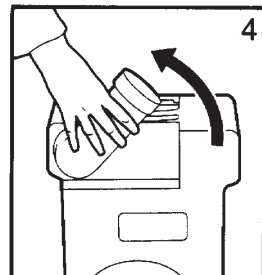
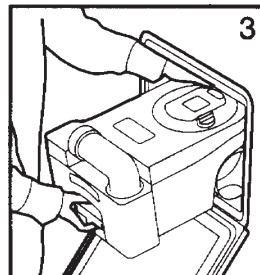
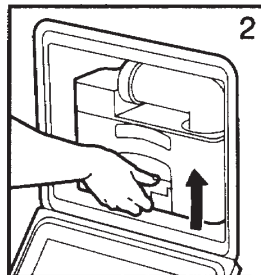
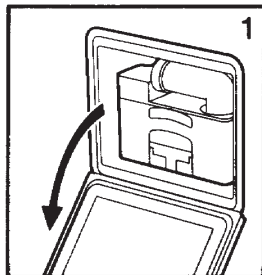



# THETFORD TOILETS

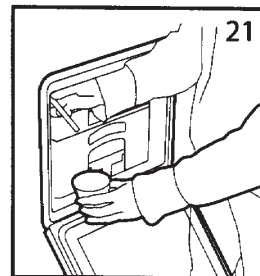
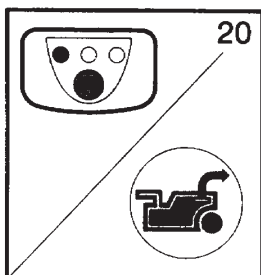
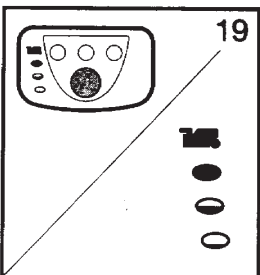
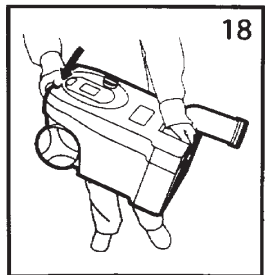
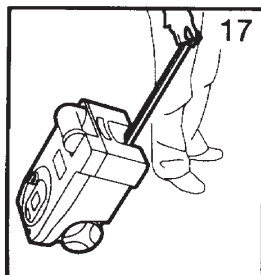
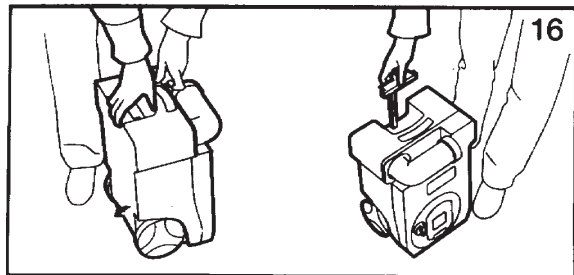
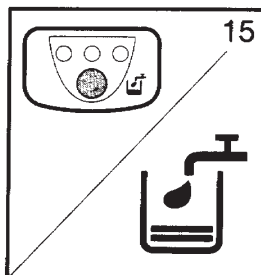
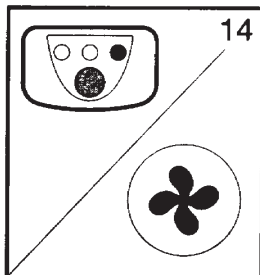
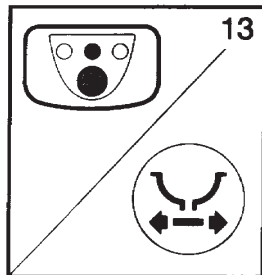



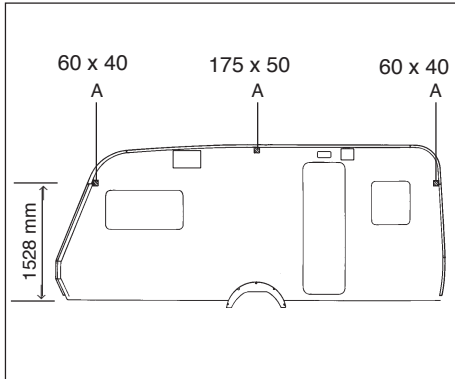

## AWNING FIXING POINTS

In all Venus Caravans fixing blocks for the awning brackets are now fitted as per the diagram (position A). The centre block is determined from centre of wheel arch and just below awning rail.

The end fixing points are just above window height front and rear, approximately 60mm long x 40mm, 1528mm above the underside of the floor (i.e. from top of skirt).

**Care must be taken when fixing the brackets and a suitable sealant used.**

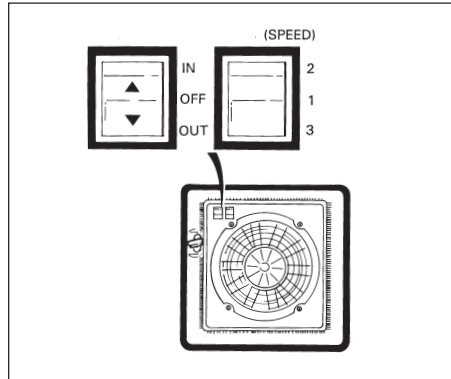

## 12 VOLT ROOF MOUNTED EXTRACTOR FAN

The fan is a double glazed rooflight. Its side operating mechanism allows a completely free central opening with built-in fixed ventilation when closed.

## TILT & SLIDE ROOFLIGHT

To open - turn the handles to release the rooflight. Push it upwards and slide it towards the front of the caravan.

Before travelling ensure the rooflight is in the fully closed and locked position.

A fully adjustable flyscreen and black out screen are built into the frame.

## STATUS TV ANTENNA

1. Switch ON the Power Pack and the red LED will illuminate.
2. Check the gain control switch is set to the normal 'NML' position.

Turn on your television set and tune in. This may be necessary at all new locations.

Should you experience problems please refer to the fault finding paragraph.

## Removing the Pinnacle

This may be necessary should you wish to reduce the overall height of the antenna by 90mm.

1. Simply unscrew the Pinnacle and remove. The antenna is designed to remain watertight without the Pinnacle.



# ANTENNA

2. To replace, simply screw in and tighten **BY HAND**.
3. **IMPORTANT** - The Pinnacle is an integral part of the antenna and critical to its performance. When in use always ensure the Pinnacle is fitted.

## Removing the Antenna

A permanently fitted Status may be removed if there are severe height restrictions, leaving only the Mounting Foot in place.

1. Unplug the antenna from the Power Pack. On the Adapter loosen the two grub screws and lift off whilst carefully

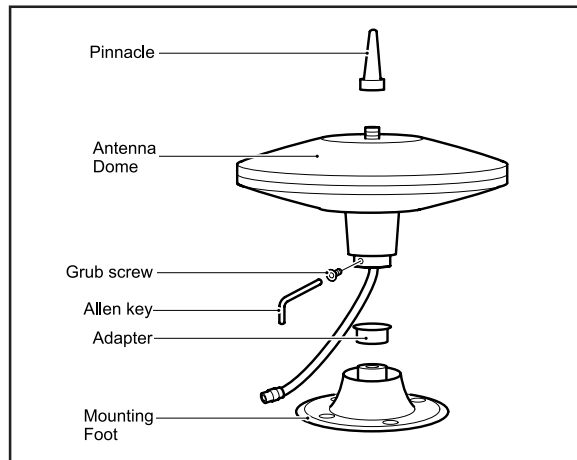

feeding out the coaxial cable with plug attached.

2. Push the Blanking Cap supplied into place to cover the central hole.

## FAULT FINDING

The following are some of the key areas we suggest you check which generally sole the most common problems encountered with the operation of the Status antenna.

## Coaxial Plugs

It is critical that all coaxial plugs in the system are fitted correctly.

## Coaxial Cable

Sharp bends, kinks and hot surfaces can easily damage coaxial cable and should be avoided. An inspection of the cable routing is recommended to ensure all is correct. Coaxial cable, if placed in close proximity to electrical cables, transformers or other pieces of electrical equipment, may pick up electrical interference causing picture quality to deteriorate.

## Pinnacle

The pinnacle is essential for the optimum performance of the antenna and therefore should be in place when the antenna is in use.

## Gain Switch

Situated below the LED light on the Power Pack, this switch should be set to the normal 'NML' position for general use. The Low setting may be used when situated close to TV transmitters where strong signals may be affecting the quality of the picture.

## Red LED Light

Should the red LED on the Power Pack not light, first try unplugging the cable connected to the Antenna Dome from the 'ANT-IN' socket. If the LED then illuminates the fault lies with either the coaxial plug or the coaxial cable, please refer to these areas described earlier.

**The Clubman and Delta ranges have the new Status 530, a fully adjustable antenna for height, direction and polarity.**

**When travelling adjust the antenna so that it points to the rear of the vehicle to reduce the possibility of damage.**

For assistance contact your dealer or Grade UK Ltd. Tel: 0115 986 7151.



### **LED LIGHTING**

LED lighting is non replaceable.

### **CD/RADIO/MP3 PLAYER**

Your caravan is fitted with a Kenwood CD/  
Radio/MP3 Player.



# FLYSCREENS & BLINDS

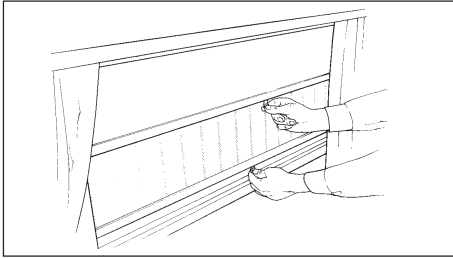

## FLYSCREENS AND SUNBLINDS

**Important:** Blinds should be checked for holes and tears when you take delivery of your caravan. Failure to report a fault at this stage will result in a claim under warranty being rejected.

## OPERATING INSTRUCTIONS

### Flyscreen

Pull the flyscreen fully down and gently push the crossbar towards the window so that it locates in the retaining “cut out” within the rear channel of the lateral guides. To release, gently pull the crossbar downwards and toward you and allow the tension of the spring mechanism to rewind the flyscreen upwards.

**DO NOT RELEASE THE HANDLE** – causing the flyscreen to “whiplash” upwards – as this will cause damage to the spring mechanism.

### Sunscreen

The front channel of the lateral guides has a

number of “cut outs” to enable the sunscreen to be retained at various heights – look inside the lateral guides to locate these. To raise or lower the sunscreen follow similar procedure as with the flyscreen.

## TENSION ADJUSTMENT

The tension adjustment clips are located at the left side of the cassette – the top one is for the flyscreen and the lower one for the sunscreen.

Insert screwdriver into tension clip, apply gentle inward pressure and rotate tension clip one or two clockwise turns to increase tension or anti-clockwise to reduce tension. Gently release the inward pressure to enable tension clip to re-engage into its internal ratchet. Check tension and, if necessary, repeat until the crossbars return to their top positions without too much tension or assistance. **DO NOT OVERTENSION.**

**Note: It is not recommended that the window blinds are retained in the “down” position whilst the caravan is being towed.**

## WINTERISATION

The flyscreen/sunscreen should NOT be left in the “down” position through the winter as this may cause the spring mechanism to lose tension.

However to rectify this, gently pull crossbar downwards and toward you then allow the

tension remaining in the mechanism to rewind, when it stops pull the crossbar downwards and upwards five or six times to restore correct tension.

Should the blinds not retract fully, please follow Tension Adjustment instructions.

## DOOR FLYSCREEN

### 1. To close

Pull handle/crossbar across door aperture until hook engages on closing profile.

### 2. To open

a) **From inside:** To release hook, pull handle/crossbar slightly toward you then, still holding the handle/crossbar, allow the tension to pull the flyscreen back into the cassette.

b) **From outside:** To release hook, push handle/crossbar away from you then, still holding the handle/crossbar, allow the tension to pull the flyscreen back into the cassette.

**Caution: To avoid damage to the tension mechanism DO NOT allow the flyscreen to “whiplash” back into the cassette.**

### 3. Cleaning

Use a damp cloth and, if necessary, a normal household cleaner without abrasives or solvents.

**Please note: Do not tow with flyscreen closed.**

**Do not leave flyscreen closed for long periods (more than 3 weeks).**



## WINDOWS

The windows on your caravan are made from acrylic. If you consider the instructions below, the windows will stay in good shape for a long time. Windows also require periodic maintenance and checking by your dealer at least once per year.

### Operation



When the vehicle is in motion all windows must be fully closed.



Never use the blinds in direct sunlight. If you use the blind in direct sunlight, even for a short period, heat will accumulate between the window and blind possibly causing damage to the window such as bending/ballooning.

Your windows are equipped with either handles with buttons or handles with stays. Please observe the following operating instructions.

**Handles with buttons** - Always push the button when opening/closing the handle.

**Stays in step version** - You will hear clicks when opening the window. Every click represents the position in which a window can stay opened. When closing the window, you must open it till the end and then close. Do not try to close it without first opening it as wide as it goes, as this will damage the stays.

**Stays with knob screw** - Always make sure to unscrew the knob before closing the window.

**Catches** - The catchers enable three positions of the window. The open position is where the handle is open placed on the outer part of the catcher. If the handle is placed in the middle of the catch, this is the position for ventilating. The closed position is where the handle is closed on the inner part of the catch.

### Cleaning

#### 1. Cleaning window profiles

To clean coloured and anodized profiles, use a soft cloth and water without any aggressive cleaning solvents. The use of any chemicals and abrasive cleaners could damage the surface of the profile.

#### 2. Cleaning windows

Never use abrasive or corrosive substances or solvents on windows, such as turpentine, spirit or dishwasher detergents, as they will damage the acrylic and/or print. We recommend cleaning with a generous amount of water or mild cleaner intended for use on acrylic. There are some specialist plastic cleaning agents such as Plexus or Brilliance which can be used if preferred. Cleaning with a dry cloth can damage the acrylic and leave scratches; always use a

moist sponge or moist soft cloth. Never clean windows with a high pressure washer. Please also note that a carwash can cause scratches or other damages.

**Acrylic material can get scratched very easily. Please consider the above instructions for cleaning, so that you will not cause scratches or other damages.**

### Condensation

Condensation can appear on the window or between both panes. This is a normal occurrence that appears because of different temperatures inside and outside, moisture and the properties of acrylic itself. Condensation will disperse after some time. This doesn't mean that there is something wrong with the window or that it is leaking. With a properly ventilated vehicle you can in most cases prevent condensation.

### How to overcome condensation

#### 1. Improve ventilation

- Leave rooflight open or use a self-ventilating rooflight.
- Add to the ventilation by fitting more improved ventilators.
- Put windows onto night vent position.
- Leave doors open between compartments.



## WINDOWS AND BODY

---

### 2. Help yourself tips

- (a) Do not wash crockery last thing at night, it creates more moisture in the air.
- (b) Do not boil water last thing at night and empty all water from kettles, etc.
- (c) Remove flowers or vases containing water from sleeping quarters.
- (d) Keep temperature at night to a minimum (hot air contains water vapour).
- (e) Increase ventilation to above normal in inclement or very wet weather.

**Note: You cannot expect to eliminate condensation completely but following the hints above will help towards a more comfortable environment.**



## CLEANING THE CARAVAN BODY

It is wise to wash the caravan body regularly in order to maintain its good looks. Do not use aggressive cleaning materials as this will damage the paintwork over time. 'T Cut' or other similar cleaning compounds should only be used occasionally for stubborn marks. We suggest that a good quality car wax, applied at least once a year, will enhance the paintwork and ease the cleaning operation.

### Glassfibre Reinforced Plastic (GRP)

GRP components need to be washed, waxed and taken care of like a car. Chemicals and dirt can collect during storage, and the gel coat can be stained or marked when chemicals combine with rain or dew. Most stains or marks can be removed with mild dishwashing detergent, but more stubborn marks may require a (fine grit) rubbing compound such as T-cut.

To help keep your GRP components looking almost like new, it is wise to wash the parts monthly (or more frequently) using mild dishwashing detergent, but avoid using strong alkaline (e.g. tri-sodium phosphate) or acidic cleaners or abrasives. Waxing the components once or twice a year with a good grade paste wax will help to maintain the colour and finish.

A significant benefit of using GRP components is the ability to repair most scratches or damage that may be inflicted upon the panel. GRP components are tough, but like any other products they can be damaged. Excessive pressure or impact to the face or reverse of the component can cause the gel coat to crack. This does not mean the entire panel is damaged and the standard industry method of dealing with such a crack is to apply a minor repair.

Any scratches or nicks that occur in normal use can usually be removed with rubbing compound. If the scratch is too deep, then (fine grade) wet sandpaper may be used followed by rubbing compound and finally wax.

One of the characteristics of GRP is the way light may be transmitted through the component. If the component is viewed from the gel coat side it will appear opaque and of a solid colour. However, if viewed from the reverse side with a strong light source behind the laminate, some light will be transmitted. This is normal for components of this thickness.

## BADGES

Resin coated badges are now being widely used within the caravan industry. Their upkeep is simple, use soap and water only to clean them. Under no circumstances should abrasive cleaners or solvent based solutions be used on them.





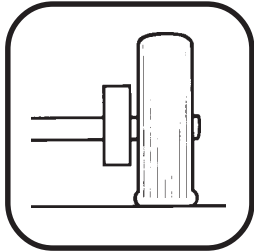

# AL-KO CHASSIS & TYRES

Chassis .....	80
Running Gear .....	80
Braking System .....	80
General Maintenance .....	83
Tyres .....	84



# AL-KO CHASSIS & TYRES

## CHASSIS & UNDERGEAR

### Never Overload!

- No overloading of the vehicles in excess of the permissible total weight.
- Avoid over-stressing of the hitch or suspension system. Avoid subjecting the axles to any impacts or jolting.
- Adapt your driving speed to the road conditions and the load condition of the caravan. This applies particularly when negotiating bends.
- Ensure that wheels and tyres are not overloaded.
- Protect the brakes against overheating on long downhill stretches, such as mountain passes in the Alps, by taking breaks in driving.
- Servicing of the chassis and braking system should take place once every twelve months by a qualified engineer or approved dealer.

### Operating Instructions which should also be adhered to by the driver

- Do not leave the handbrake on for long periods of time.
- The handbrake, when in good working order, will retard the trailer by 18%. When parking on steep slopes it is highly recommended that wheel chocks are used.

- When raising and lowering the jockey wheel, excessive force should not be used on the handle as this could result in damage to the mechanism.

### Inspections prior to each run

- Tyre pressure and tyre condition.
- Wheel fastening.
- Functioning of lighting and the braking systems.
- Raise and secure the jockey wheel. The jockey wheel should be parallel to the direction of travel at all times.
- Inspect the hitch. The coupling must fully enclose the ball-head and be locked.
- Secure the breakaway cable to the towing vehicle.
- Release parking brake.

### Handling (operation)

#### Coupling and uncoupling

**Note:** The handle of the ball hitch and the handbrake lever must not be used as a manoeuvring aid. There is a risk of damage to the internal components.

The coupling head (ball-head hitch) on your BPW chassis is design-tested. The maximum load supported at the coupling point must be complied with. Lower the jockey wheel to the ground. Reverse the towing vehicle up to the caravan or move the caravan to the coupling point.

## COUPLING HEAD

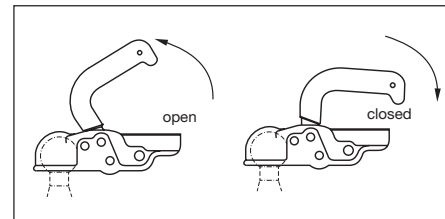

### Coupling

Mount open ball-head hitch on the ball and press downwards until the operating lever is horizontal to the ball-head hitch.

Connect the breakaway cable and electrical plug to the towing vehicle.

Wind up the jockey wheel fully and secure by firmly clamping it. Release parking brake before setting off.

### Uncoupling

Lower the jockey wheel down.

Disconnect breakaway cable and electrical plug.

Apply the parking brake. Open the ball-head hitch by swinging the operating lever in the direction of travel and lift up off the ball.



## SAFETY COUPLING "WS 3000 D"

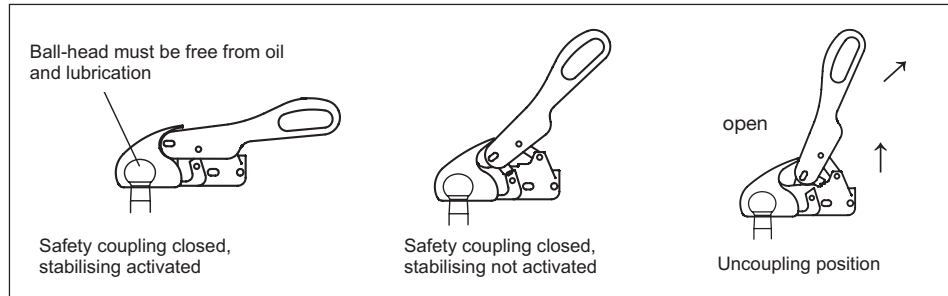

### Coupling

Place the open ball-head hitch on the ball-head of the towing vehicle (grease-free). If pressed simultaneously downwards - usually the support load is sufficient - the ball-head is closed automatically and locked securely. The stabilising device is activated by moving the operating lever down to the stop, i.e. opposite to the direction of travel. In doing so the spring element is tensioned, thus generating the contact pressure onto the ball-head of the coupling via the friction pads. Connect the breakaway cable and electrical plug to the towing vehicle.

Raise the jockey wheel fully upwards and secure. Release parking brake before setting off.

**Visual Check** - the ball-head should no longer be visible in the coupled condition.

Noises may occur during driving as a result of the friction between the friction pads and the ball hitch. However, these noises do not have any effect on the function of the trailer ball hitch.

### Uncoupling

Lower the jockey wheel down.

Disconnect breakaway cable and electrical plug.

Apply the parking brake. Open the ball-head hitch by swinging the operating lever in the direction of travel whilst simultaneously pulling the handle towards the caravan. (see illustration above).



## AL-KO CHASSIS & TYRES

### MODE OF OPERATION OF iDC

- Continuous registering of lateral acceleration by means of a sensor.
- Evaluation of the signals registered by means of special software from BPW.
- The software detects critical driving situations which require an intervention of iDC.
- As soon as the limits stored in the software are exceeded, iDC intervenes, in that the motor located in the control unit activates the steering rack via the gearbox.
- With the aid of an actuating link mounted between the steering rack and the brake linkage, braking is initiated via the brake cable assemblies.
- Once the car and caravan have been stabilised, the steering rack returns to the starting position and releases the wheel brake again.

LED (colour/cycle)	Operating	Action
Green / continuously	Ready for operation	-
Green / rapidly	Start-up self test active	Not required, wait for self test
Green / slowly	Brakes hot / system inactive	Not required, wait maximum 100 seconds
Green / flashing 5 seconds	Standby / power save	Not required, wakes up on movement in the towing direction
Red / flashing once	Fault: central unit	Check central unit for damage
Red / flashing twice	Fault: sensor	Check sensor cabling and/or sensor assembly
Red / flashing three times	Fault: power supply	Check cabling, check vehicle voltage, start vehicle



## GENERAL NOTES ON MAINTENANCE

### Tyre Wear and Damage

The legal requirements for tread depth on motor vehicles apply also to caravans. In order to equalise wear it is suggested that wheels be balanced and changed around from time to time.

It is dangerous to neglect tyre damage and should you detect a blister, rupture or cut exposing the casing, or if it has suffered a violent impact (for example against a kerb), such that there is a risk of internal damage, it is advisable to have it examined by a tyre specialist as soon as possible.

### Wheels

The condition of wheels should be checked regularly particularly for distortion of flanges and the wheel dish. Wheels dam-aged or distorted, or having wheel bolt seatings cracked or deformed must not be repaired.

### Couplings

1. Clean and grease spherical seat, bearing parts and pivot pins regularly.
2. Thoroughly examine all moving parts for wear and correct functioning.
3. Couplings should never be drilled.

### Towing Ball

The automobile towing ball should measure

50mm maximum and 49.5mm minimum (DIN 74058). If the ball is found to be worn it should be replaced immediately.

### Overrunning Device

The device housing is packed with grease on assembly, but will require periodic maintenance to ensure smooth operation of the braking system.

1. Regrease the shaft bearings via the grease nipples provided at 3000 mile intervals and before storage.
2. Ensure correct functioning of all pivot pins and levers and oil regularly.

### Jockey Wheel

Lubricate wheel and screw thread periodically.

### Brake Linkage

All moving parts should be lubricated periodically to ensure their satisfactory operation.

It is recommended that all brake linkage threads are liberally smeared with grease for protection and as an aid to future adjustment of the system.

### Corner Steadies

The screw and pivot pins should be lubricated periodically to ensure their satisfactory operation.

### Braking System

At 500 miles then every 3000 miles or 1 year check and adjust brake linkage to compensate for any stretch of the bowden cables.

Check and adjust wheel brakes to compensate for wear.

**IMPORTANT** When replacing the wheels you should tighten the nuts in rotation diagonally, taking care to tighten them equally.

The recommended torque is 88Nm (65lbs/ft) for steel wheels. Alloy wheels should be 115Nm (85lbs/ft).

### CHECK THE WHEEL NUTS BEFORE STARTING EVERY JOURNEY

#### IMPORTANT NOTICE:

The caravan is manufactured for towing behind road cars and the 4 x 4 "off road" type of passenger car derivative. THE CARAVAN IS NOT SUITABLE FOR TOWING BEHIND COMMERCIAL VEHICLES.



# AL-KO CHASSIS & TYRES

## TYRES

### PREPARATION

#### Tyres & Tyre Pressure

Safe driving and handling when towing a caravan is very important and one major factor which is frequently overlooked is the tyres. Look after your tyres properly and you will improve the safety and behaviour of your car and caravan.

#### Check the Pressures

Whatever tyres are fitted to the towing car and caravan it is essential to the safety and stability of the combination that all tyres are correctly inflated. This is a 'golden rule' of motoring and of caravanning in particular.

Pressures should be checked when the tyres are cold, not warm during or just after a run when they will be higher. Never reduce pressures when tyres are warm as they could be too low when they cool down.

The tyres specified by the caravan manufacturer are satisfactory for towing in the UK and are rated up to 80mph (130kph) at the maximum design weight of the caravan. In certain countries overseas it is legal to tow at higher speeds. If it is intended to visit such countries and tow up to the higher speed limits then it is important that the suitability of the tyres is first checked with a caravan dealer.

#### Tyres & Pressures

The tyres fitted, and the pressures needed, vary from model to model. Check the Service Handbook for specific recommendations for your model.

The speed limit for towing a caravan in the U.K. is 60mph. If a tyre needs to be replaced you must ensure that you refit a tyre of the same specification. The correct pressure for your car tyres will be found in the car handbook.

#### Fit the Right Tyres

As with all road vehicles it is always advisable to have the same type of tyres on all wheels i.e. both on the towing vehicle and the caravan but it is recognised that caravans and trailers will frequently have a different type from the towing vehicle.

If a wheel or tyre has been changed the replacement has to be of the same type of construction and size as on the other wheels.

#### General Recommendations

Because caravan tyres and wheels are rarely the same as those on your car you must not attempt to use the car wheel on your caravan if you should have a puncture.

Check your tyres regularly but particularly when the caravan has not been used for a long time. Vehicles such as caravans if not used in the winter should be thoroughly inspected prior to re-use during the summer months. Look particularly for any signs of age deterioration in the tyres such as sidewall cracking and carcass deformation. Tyres on a stationary vehicle, particularly if parked in coastal areas, always age and crack more quickly than those which are run frequently and, if your caravan is going to stand for a long time it is a good idea to cover the tyres with old sacks, etc. to shield them from direct light and, if possible, to jack the weight off the tyres. If in doubt at all about your tyres have them checked immediately by a tyre distributor.

**WARNING: Prior to any journey the condition of the tyres should be inspected. The NCC recommend that tyres are replaced seven years from date of manufacture at the very latest.**

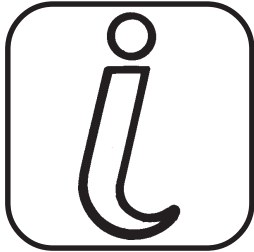

# GENERAL DATA

Wiring Diagrams .....	86
Wiring Diagram – Road Lighting .....	87
Light Bulb Replacements .....	88
Security .....	88
Owners Club .....	89
Owners Warranty .....	89
Winterization Guide .....	90



# GENERAL DATA

## VENUS CIRCUIT DIAGRAM

### COLOUR KEY

O/G-ORANGE/GREEN  
 YEL-YELLOW(AUX)  
 Y-YELLOW(C/P)  
 RD-RED  
 WH-WHITE  
 BL-BLUE  
 RD/O-RED/ORANGE  
 O-ORANGE  
 BL/RD-BLUE/RED  
 G/B-GREEN/BLUE  
 G/RD-GREEN/RED  
 O/BLK-ORANGE/BLACK  
 G/BR-GREEN/BROWN  
 B/W-BLACK/WHITE  
 G-GREEN  
 B/BR-BLUE/BROWN  
 G/BK-GREEN/BLACK  
 P-PURPLE  
 B-BLACK  
 O/W-ORANGE/WHITE  
 GY-GREY  
 Y/B-YELLOW/BLACK

### CONNECTIONS FROM 13 PIN PLUG

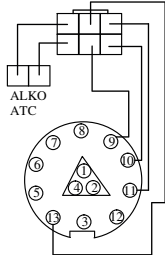

- 1) YELLOW - LEFT IND
- 2) BLUE - FOG - NEG FOR ROAD LIGHTS
- 3) WHITE - RIGHT IND
- 4) GREEN - RIGHT SIDE LIGHTS
- 5) BROWN - STOP
- 6) RED - LEFT SIDE LIGHTS
- 7) BLACK - REVERSE
- 8) BLUE/BROWN - CAR +VE
- 9) RED/BROWN - FRIDGE +VE
- 10) GREEN/WHITE - FRIDGE -VE
- 11) EMPTY
- 12) BLUE/WHITE - CAR -VE

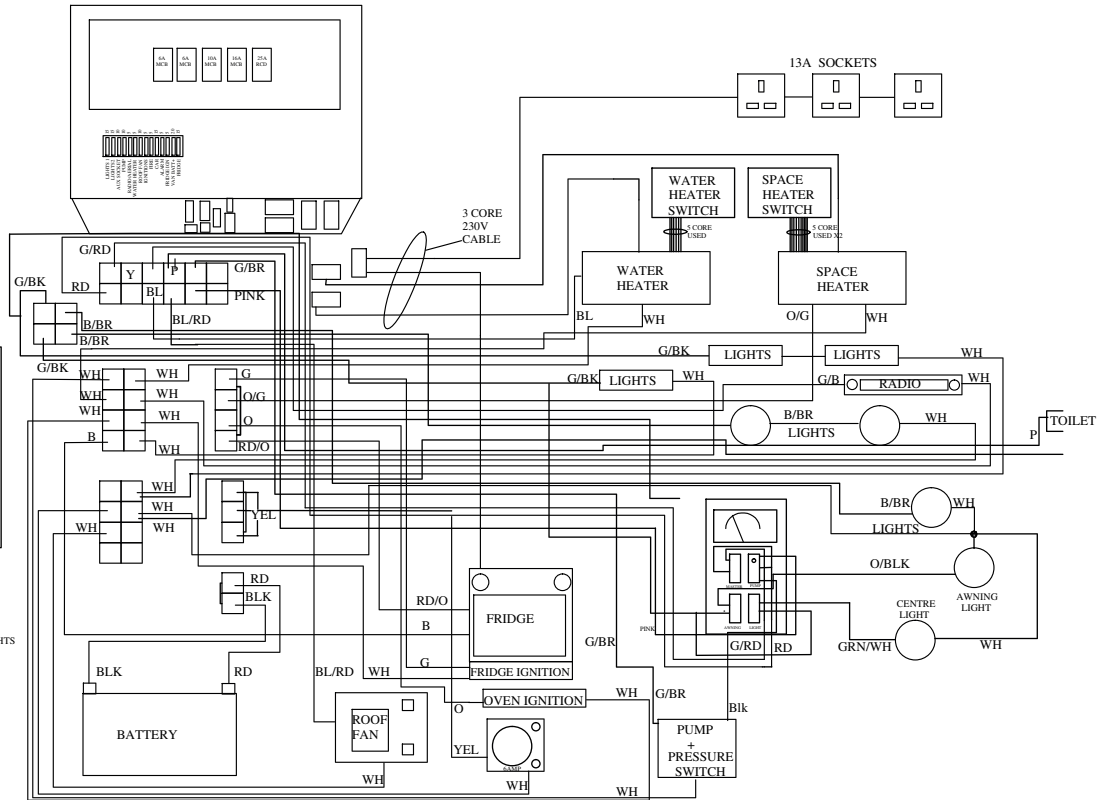





## ROAD LIGHTING WIRING DIAGRAM

NOTE: ALL CABLE SIZES GIVEN IN MM<sup>2</sup>

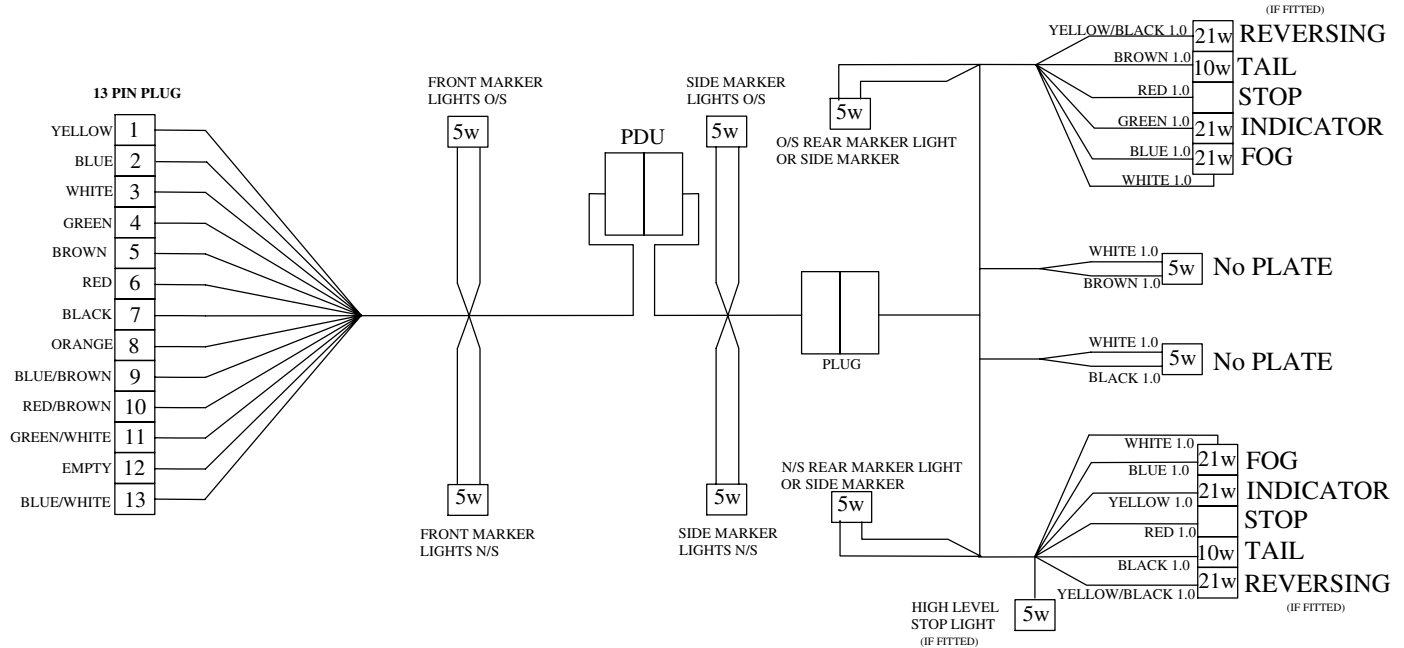



## GENERAL DATA

---

### LIGHT BULB REPLACEMENT

Brake/side light .....	Twin 21W/5W, 12V
Front side light .....	5W, 12V
Side light (white/red) .....	5W, 12V
Indicator light .....	21W, 12V
Reversing light .....	21W, 12V
Fog light .....	21W, 12V
High level brake light .....	12V LED
Number plate light .....	5W, 12V
Mains Reading Light .....	10W, 12V Halogen
Ceiling Light .....	10W, 12V Halogen
Toilet ceiling light .....	10W, 12V Halogen
Awning Light .....	12V LED Strip (None replaceable bulb)
Spot light .....	10W, 12V Halogen
Front interior corner light .....	10W, 12V Halogen

### SECURITY

Ensure that you lock all windows and doors when leaving your caravan. Fit a towbar hitch lock or a wheel clamp -consult your dealer on all safety and security recommendations.

Keep your gas cylinder locked when leaving your caravan.

Many devices are available to alarm your caravan. It is a good idea to mark your caravan in a secret place -this will help the police to identify it should it be stolen.

Caravans can be stolen from storage compounds, motorway service areas and even your own premises, so it is always wise to be vigilant at all times. Ask your dealer about details on all security aspects.



## LUNAR OWNERS CLUB

Now you are the owner of a Lunar caravan why not join the Lunar Owners Club.

This is an independent club run and organised by owners.

Lots of opportunities exist to make new friends at social gatherings and Rallies both Regional and National.

A leaflet regarding the Owners Club is within the wallet, if it is not please contact Lunar and a copy will be sent to you.

Alternatively for further information please visit the Lunars Owners Club website at: [www.lunarsownersclub.net](http://www.lunarsownersclub.net)

## OWNERS WARRANTY

Lunar Caravans Limited hereby warrants, subject to the terms, conditions and exceptions shown within the separate Service handbook, that any failure of parts and components will be repaired or replaced by the approved dealer from whom the caravan was purchased.

We expect your new Venus caravan to provide long and trouble free service, even so, it is vital that you understand the contents and follow the correct procedures, to ensure you receive the full benefit of this protection. Your legal rights are neither affected nor prejudiced against the supplying dealer and/or the manufacturer.

All Venus Caravans are supplied with a 6 year body shell integrity warranty and a 3 year manufacturers backed warranty from the date of purchase which is conditional on annual servicing being carried out within 60 days either side of the anniversary of the purchase date, except the third service which should be carried out prior to the 3rd anniversary date of the final year.

### Validating your warranty

To validate your warranty, you simply need to register your caravan purchase with us at [www.lunarcaravans.com](http://www.lunarcaravans.com). By registering your details we will be able to assist you more easily should you make a warranty claim.

Before you register please make a note of your caravan's 17 digit VIN Number and your 3 digit Registration Security Number.

The VIN number, beginning SGL, can be found on the windows. The Registration Security Number can be found on the Thetford Model Label located inside your fridge or oven. The Model Label has a Serial Number or SER. NO. and the **last 3 digits** of this number will form your Registration Security Number.

Please note that your oven and fridge will have different Serial Numbers to each other, but you can use the last three digits from either one to register your van.

Once your details have been submitted, you will be sent email confirmation that they have been successfully received.

### Additional equipment

If additional equipment (other than those on the optional list of Lunar) is to be fitted you should check with your dealer beforehand. The warranty may be invalidated.

### Vermin

Vermin can gain access via the smallest of holes. Venus fit grills and grommets to prevent this but the nature of some caravan storage means it can happen, with upsetting results. We advise setting a trap and/or poison and regular inspection.

Vermin damage is not covered by warranty.



## GENERAL DATA

---

### CRiS

CRiS is the Central Registration & Identification Scheme that issues touring caravan registration documents, equivalent to that of the V5 registration document issued by the DVLA for cars. CRiS was established in 1992 by The National Caravan Council and provides a method of registering the 'keeper' details of every tourer manufactured by NCC member companies to help prevent and detect caravan related crime.

### Why register with CRiS?

- Safety
- Security
- Warranty

### Did you know...?

- You should not take a tourer abroad without a registration document. If you go abroad your CRiS registration certificate provides the necessary proof, required by the police and other authorities, that you are its registered keeper.
- If you need to make a claim on your insurance, CRiS can help speed up claims by providing details of your tourer and its purchase date to relevant parties.

- CRiS can help your tourer's manufacturer contact you in the event that there is any kind of product recall or fault that could affect the safety of your caravan.

For help, support and advice, contact CRiS:

NCC CRiS Ltd  
PO Box 445  
Aldershot  
GU11 9SF  
Tel: 0203 282 1000

[www.cris.co.uk](http://www.cris.co.uk)

Opening hours: Monday – Friday 8am to 8pm  
Saturday 9am to 5pm  
Sunday 10am to 5pm.



## CARAVAN WINTERIZATION GUIDE

If the caravan is to be stored for any length of time, the following procedure is advisable:

### 1. Location

If possible avoid siting the caravan beneath trees or near dilapidated buildings, where strong winds may dislodge branches or slates that can damage the caravan. In exposed conditions ground anchors may be advisable. Be wary of low lying areas that may be prone to flooding.

### 2. Covers

Large polythene or tarpaulin sheets should not, in the opinion of most experts, be used to 'seal' the caravan against the elements. Condensation and mould growth may be encouraged and any flapping material or guy ropes could scratch acrylic windows.

If you feel a cover is absolutely necessary because of where the caravan is parked, however, purchase one that is made of "breathable" material.

### 3. Ventilation

Caravan vents should be left uncovered to provide adequate air circulation inside the caravan; however if in an exposed or salty location the vents on the side of the prevailing wind and/or the 'fridge vent may be closed off for the winter. If you have

regular access to the caravan, you could place some moisture absorbing crystals in cupboard corners to reduce the risk of condensation, but these will require fairly frequent changing.

### 4. Interior

To prevent possible mould growth over the winter, clean and vacuum carpets, curtains and upholstery and if possible remove the soft furnishings and store in a warm, dry place (eg attic). If not possible to remove the cushions, store on edge away from the caravan walls, allowing air to circulate around them and cover with an old sheet to prevent fading in the sunlight.

Walls and ceilings should be wiped over with a mild anti-bacterial solution (eg Dettol) and can be polished afterwards if desired. Cupboards should be emptied, cleaned and vacuumed out. Small doors can be left ajar to assist ventilation, but larger doors should be closed or they may warp.

The refrigerator should be emptied, cleaned with a solution of bicarbonate of soda or anti-bacterial solution and the door left ajar.

The hob/oven should be thoroughly degreased and cleaned. If using one of the stronger oven-cleaners on the market be sure to allow plenty of ventilation whilst working. If necessary burner jets can be

brushed over with a stiff brush, and blockages cleared with a high-pressure air line. Never try to clear blocked jets with a piece of wire which can damage or enlarge jet holes.

Water heaters must be drained and care must be taken to remove any lurking pools of water or frost damage may result. If possible blow air through the heater to push any water droplets through. Leave drain taps and inlets open.

The water pipes can be flushed through with a proprietary sterilising agent and the waste pipes with a stronger disinfectant. Make sure the water pump is drained and remove the water filter. Fresh and waste water containers should be cleaned, drained and stored with caps loose or off. Leave all water inlets and outlets open, but they may be covered with a fine mesh material (eg stocking) to prevent entry of insects etc.

The toilet should be cleaned according to the manufacturer's instructions, using a suitable disinfectant for the holding tank. Rinse all sections thoroughly and store unsealed. Any rubber seals or diaphragms can be lubricated with olive oil to prolong life.

### 5. Battery

Unless powering an alarm system, the 12v battery should be removed, wiped over, the terminals cleaned and smeared with



## GENERAL DATA

---

petroleum jelly. The electrolyte level should be checked and topped up with distilled water if necessary. Trickle charge from the mains until you obtain a reading of 12.6v on a voltmeter or 1.27 on a hydrometer. Store the battery in a cool, dry place and check the state every 6-8 weeks. Top up the charge as required.

Electric clocks, smoke detectors etc, if fitted, should have their internal battery removed. Battery powered burglar alarms may benefit from a new set of batteries for the winter.

### 6. Awning

The awning should be spread out on dry grass or concrete and brushed with a broom to remove any mud. If the canvas is stained try removing the marks with a stiff brush and plain water. If this fails pure soap flakes can be tried, which will mean re-proofing is necessary afterwards, but never use detergents. If stains are stubborn there are proprietary cleaners such as Fabsil Universal Cleaner, available from caravan accessory shops, or contact Grangers International Tel: 01773 521521. Any mildew spots can be treated with a weak solution of hydrogen peroxide – scrub into the affected area and allow to dry before re-proofing (spot test a hidden area in case colour is affected). Such severe treatment will weaken the awning material so live with stains if you can! Clear windows can be cleaned with methylated

spirits if water doesn't work, but nothing stronger. Examine seams and repair any broken stitching and replace perished rubber tensioners. Give the awning a good shake and pack it when completely dry, trying not to put too many creases in the window. Store in a dry, vermin free area.

Awning poles need little attention other than a wipe down with a damp cloth. Don't oil or grease them as this may get onto the canvas. Pegs can be cleaned and straightened and any badly damaged ones can be replaced ready for the next season.

### 7. Exterior

Your caravan is constructed through the use of several types of materials, paints and coatings in the course of manufacture. Side walls have strengthening inserts in areas which are painted or coated, such materials vary in their make up and over time react differently in opposing areas to atmospheric, chemical and UV influences.

In some instances this can result in a yellowing or matting of components and finishes to varying degrees. This UV or chemical yellowing in no way compromises the usability or performance of the product and if desired, in most cases, can be restored by polishing with a compound such as T-Cut (always follow the manufacturers recommended guidelines). The caravan will

also benefit with regular thorough cleans with a car wash wax type of shampoo.

Look over the rubber window seals and replace any that look perished. Coat serviceable rubbers with olive oil. If you have a damp meter check around the inside for any trouble spots and re-seal suspect joints. Any major damp penetration problems should be resolved before storage. Minor leaks might be cured using Captain Tolley's Creeping Crack Cure. Major leaks require complete renewal of the sealant; both products should be available from caravan accessory shops.

### 8. Chassis

The chassis should be brushed off, or if exposed to corrosive elements, eg road salt, thoroughly washed down. Any surface rust can be removed with a wire brush or sandpaper and the chassis and axle tube can be painted with a rust inhibitor, suitable paint (eg Hammerite) or Finnigan's Waxoyl. The coupling and all winding mechanisms should be degreased, examined for wear then re-greased.

### 9. LPG cylinders

LPG cylinders should be removed and stored in a cool, ventilated location. Some storage compounds will insist they are removed to comply with fire safety regulations. The regulator and/or pipe end can be covered



with a stocking or similar to prevent the entry of debris or insects that can block the gas supply.

### **10. Electrics**

13 pin, 12N and 12S plugs should be inspected and cleaned and the pins coated with vaseline. WD40 should not be used as it may 'melt' some plastics on contact. The plugs should be protected from the weather but not fully sealed in polythene which will encourage condensation. Road lights should be checked and any water ingress cured, full inspection and cleaning can be done now or left to the springtime service.

### **11. Axle stands**

Ideally the caravan should be jacked up and supported on axle stands with the wheels clear of the ground. Wheels can be removed if desired and stored in a cool, dark place at normal inflation pressure. Inspect tyres carefully and make a note to renew any suspect ones before using the caravan again. The corner steadies should be lowered and rested on blocks if they do not reach the ground. The handbrake should be left off and the wheels rotated from time to time to keep the bearings lubricated.

### **12. Security**

Finally remove any valuables and documents from the caravan to make it secure; thieves do not hibernate for the winter!

Please note that neither Lunar Caravans Ltd nor The Caravan Club endorse any of the listed products and you should satisfy yourself as to their suitability. As always, check that the installation of an after-market accessory does not invalidate your warranty.





<b>A</b>			
Arrival on Site .....	24		
Levelling the caravan .....	24		
Siting/Unhitching .....	24		
Awning Fixing Points .....	73		
<b>B</b>			
Battery .....	49		
Blinds .....	76		
Breakaway Cable .....	17		
Bulb Replacement .....	90		
<b>C</b>			
Caravan Handling .....	22		
Caravan Towing Code .....	4		
Carbon Monoxide Alarm .....	29		
Chassis & Undergear .....	82		
General Notes on Maintenance .....	85		
<b>D</b>			
Distribution of Weight .....	8		
<b>E</b>			
Electrics .....	42		
13 pin wiring diagram .....	20		
230V Mains Electric Equipment Usage .....	42		
Control Panel .....	48		
Instructions for Electricity Supply .....	42		
Power Distribution Unit .....	46		
<b>F</b>			
Fire Action .....	28		
Fire Extinguisher .....	29		
Fire Precautions .....	28		
Flyscreens .....	76		
Fuses .....	89		
<b>G</b>			
Gas .....	38		
Gas Bottles .....	38		
Gas Safety Advice .....	40		
Precautions .....	40		
Types of Gas .....	39		
General Data .....	90		
Lunar Owner's Club .....	91		
Security .....	90		
Servicing .....	91		
<b>H</b>			
Hob			
Thetford 3 Burner Hob .....	63		
<b>J</b>			
Jacking Points .....	23		
<b>L</b>			
Lighting .....	75		
<b>M</b>			
Mains Power Unit .....	46		
Mirrors .....	19		
Motorway Driving .....	22		
<b>N</b>			
Noseweight .....	6		
Number Plate .....	19		
<b>O</b>			
Oven			
Spinflow Combi Oven .....	61		
<b>P</b>			
Pre-load Checklist .....	8		
Pre-tow Checklist .....	10		
<b>R</b>			
Refrigerators .....	54		
Dometic Model RMS 8500 .....	54		
Reversing .....	22		
Road lighting .....	20		
<b>S</b>			
Security .....	30		
Vehicle Identification Number (V.I.N.) .....	30		
Smoke Alarm .....	28		
Speed Limits .....	22		
Stabiliser, AKS2004 .....	11		
Stability .....	9		
Stabilisers .....	9		
Sterilising .....	34		
<b>T</b>			
Toilet			
Cassette Toilet C-260 CWE .....	65		
Truma Combi Boiler .....	52		
TV Antenna .....	73		
Tyres .....	18, 86		
General Recommendations .....	86		
Tyres & Pressures .....	86		
<b>V</b>			
Vermin .....	91		
<b>W</b>			
Water System			
Helpful Hints .....	37		
Pressure Switch .....	37		
Setting Up the Water System .....	36		
Wheel Changing .....	23		
Wheel Lock .....	13		
Wheels			
Torque .....	18		
Winterization Guide .....	93		
Wiring Diagrams .....	89		
Warranty			
Extended Warranty .....	91		
Owner's Warranty .....	91		
Validation .....	91		



## NOTES

---

Publication Designed and Produced by Preset Graphics Ltd  
Tel: 01332 549278. Fax: 01332 549279. E-mail: [Presetgraphics@btconnect.com](mailto:Presetgraphics@btconnect.com)  
Ref: 21347 © All Rights Reserved