

Y
do

FIRST CUSTOMER REGISTRATION DETAILS

Name _____

Address _____

Post Code _____

Caravan Model _____ Door Key No _____

V.I.N. S G L _ _ _ _ L U _ _ _ O _ _ _ _ _

Sold by (*Dealer stamp*)

Date of Sale _____ Date pre-delivery inspection completed _____

For Full Warranty Information see page 109 and the Service Handbook supplied separately.

To find out how to validate your warranty see page 109.

CONTENTS

TOWING CODE



PREPARING FOR THE ROAD



ON THE ROAD



FIRE & SAFETY



SERVICES



ELECTRICS



FITTED EQUIPMENT



AL-KO CHASSIS & TYRES



GENERAL DATA



INTRODUCTION

INTRODUCTION

Lunar Caravans Ltd. welcomes you as you join the ranks of owners of Lunar Caravans. We hope you will enjoy your caravan and this handbook tells you how to look after it so that it may give you years of pleasure and enjoyment.

Remember that it is a vehicle and thus calls for a small amount of regular maintenance.

You are requested to contact your dealer on all enquiries in order to ensure satisfaction. You will only experience delays if you bypass the normal channels.

Your Lunar caravan has been built and approved to EN1645 which applies to a large number of features such as:

- sizes of beds
- escape factor i.e. windows and exterior door
- materials
- design and construction
- insulation is grade 3 classified which is able to achieve an average temperature difference of 35 degrees centigrade between interior and exterior when the exterior is -15 degrees centigrade
- electrical equipment, both 12 volt and 230 volt

- chassis
- undergear
- drawbar
- jockey wheel
- wheels and tyres
- installation of gas
- ventilation
- awnings and channel
- fire notices
- handbook

Touring caravans are designated by their model year which runs from 1 September to 31 August. A new year model can only be registered by CRIS from 1st September onwards.

This caravan has been security marked and recorded under the Caravan Registration and Identifications Scheme that is organised by the Caravan Industry.

Your Touring Caravan Registration Document will include a 17 character V.I.N. (Vehicle Identification Number), which is also chemically etched on eye level windows.

To protect yourself and your touring caravan, never leave the Registration Document in the caravan. For security reasons keep it in a safe place.

If you sell the caravan please follow the instructions on the Touring Caravan Registration Document.

If you do not receive a Touring Caravan Registration Document, lose it, or any of the details recorded are incorrect, please contact:

CRIS,
Dolphin House,
New Street
Salisbury
Wiltshire SP1 2TB
Tel: 01722 411430

Please note: Product information within this document is correct at the time of going to print. Lunar Caravans Ltd has a policy of continuous product development and therefore reserves the right to modify equipment or make improvements to the product during the course of the model year.

Disclaimer: The contents of this Handbook book are as accurate as possible at the time of going to print. Lunar Caravans reserve the right to alter materials and specifications without prior notice.



TOWING CODE

Scope of Code	4
Caravan Terms	4
Weights	4
Towing Vehicle Terms	4
Measurement of Noseweight	6



TOWING CODE

THE CARAVAN TOWING CODE

Industry Payload Standard for UK touring Caravans

This standard has been prepared by the National Caravan Council and formulated with input from Industry Experts. The standard applies to UK specification Touring Caravans and will apply for the NCC certification from 2011 onwards model year Touring Caravans.

For the 2011 model year the method of calculating the Mass in Running Order (MRO) and user payload figures are in line with European Vehicle Directives and provides for the requirements for European Whole Vehicle Type Approval EWVTA, 2007/46/EC (The Framework Directive) and the directives referenced therein.

DEFINITIONS

Maximum Technically Permissible Laden Mass (MTPLM)

The fully laden mass of the caravan in the manufacturer's standard specification which is stated in the manufacturer publications by the manufacturer for tow car matching. This mass takes into account the specific operating conditions including factors such as the strength of the materials, load capacity of the tyres etc, and can be found on a plate affixed to the caravan, usually near the entrance door.

Please note: The MTPLM is the maximum weight that the caravan can be loaded to, this mass must NOT be exceeded. However most models can have the MTPLM upgraded in capacity; this must be approved by Lunar Caravans Ltd via the dealership. Please contact your dealership for further details.

Mass In Running Order (MIRO) or (MRO)

This is the weight of the caravan as it leaves our factory (inclusive of the electrical hook-up cable at 6kg and the winding handle at 1kg) plus the following:

16kg to allow for the carrying of 2 x 5kg BP gas light bottles.

10kg of water in the water heater.

2kg of water in the toilet holding tank as this is the maximum recommended by Thetford.

User Payload (UP)

The difference between the MIRO and MTPLM (excluding potential MTPLM upgrade). The user payload allows for items common to all occupants, such as food, cutlery, pots, pans, clothing, footwear, bedding, sports equipment etc. The user payload also includes an allowance for the auxiliary battery.

The UP is calculated by the following formula:

$$10L + 10N + 50.$$

L is the body length of the caravan in meters.

N is the number of births.

50 is for normal equipment carried in the caravan, a sample list is given below.

TV	3kg
Kettle	0.5kg
Bed linen	6kg
Crockery	5kg
Saucepans	3kg
Wastemaster	6kg
Aquaroll (empty)	5kg
Waste bin	1kg
Cutlery	2kg
Toilet fluid etc	2.5kg
Battery	16kg



Optional Equipment Payload (OEP)

Items made available by the manufacturer over and above the standard specification for the caravan in addition to the user payload.

Personal Effects Payload (PEP)

A mass specified for the items which a user can choose to carry in a caravan and which are not included as an essential habitation equipment or optional equipment.

Optional Item	Additional Weight
R/C Alarm/Awning Light	1 kg
AL-KO Secure wheel locks (per lock)	2 kg
AI-KO ATC Trailer Control	2 kg
Air Conditioning	30 kg
Auto Switch over 40L Under slung water tank	47 kg

Please note: Any options fitted by retailer will reduce the overall payload available to the customer.

REGULATORY AND SAFETY ADVICE

WARNING: UNDER NO CIRCUMSTANCES SHOULD THE MAXIMUM TECHNICALLY PERMISSIBLE LADEN MASS (MTPLM) BE EXCEEDED. PLEASE TAKE CARE TO ENSURE THAT YOU HAVE ALLOWED FOR MASSES OF ALL ITEMS YOU INTEND TO CARRY IN THE CARAVAN e.g. Optional equipment and personal effects such as clothing, food, pets, bicycles, sailboards, sports equipment etc.

THE MASS OF THE CARAVAN IN RUNNING ORDER (MIRO) CONTAINS PROVISION FOR THE MASSES OF LIQUIDS, GAS ETC. PART OF THIS PROVISION CAN ALSO BE UTILIZED AS ADDITIONAL PAYLOAD IF FOR EXAMPLE YOU WISH TO TRAVEL WITH NO GAS CYLINDERS.

THE CARAVAN AND TOWING VEHICLE RATIO

This can be determined by calculation and is equal to:

$$\frac{\text{actual laden weight of caravan}}{\text{kerb weight of towing vehicle}} \times 100\%$$

THE **LAW** REQUIRES THAT CARAVANS & THEIR TOWING VEHICLES & THE LOADS THEY CARRY MUST BE IN SUCH A CONDITION THAT NO DANGER OR NUISANCE IS CAUSED.

(Regulation 100 of the Road and Vehicles [Construction and Use] Regulations 1986).

IMPORTANT NOTICE:

The caravan is manufactured for towing behind road cars and the 4 x 4 "off road" type of passenger car derivative. THE CARAVAN IS NOT SUITABLE FOR TOWING BEHIND COMMERCIAL VEHICLES.

POWER TO WEIGHT RATIO:

No hard and fast rules can be stated but, here is a general guide.

- (a) Conventional petrol engines with a capacity up to approximately 1500 cc should be adequate for towing a caravan weighing around 85% of the kerb weight of the towing vehicle.
- (b) Above 1500 cc such engines should



TOWING CODE

manage a caravan weighing up to 100% of the kerb weight of the towing vehicle and still give adequate performance.

Note: The towing vehicle manufacturer's limit is, in some cases, less than the kerb weight.

Vehicles with automatic transmission may need an oil cooler to be fitted or the SAE rating of the gearbox oil increased when towing. The advice of the vehicle manufacturer should be sought.

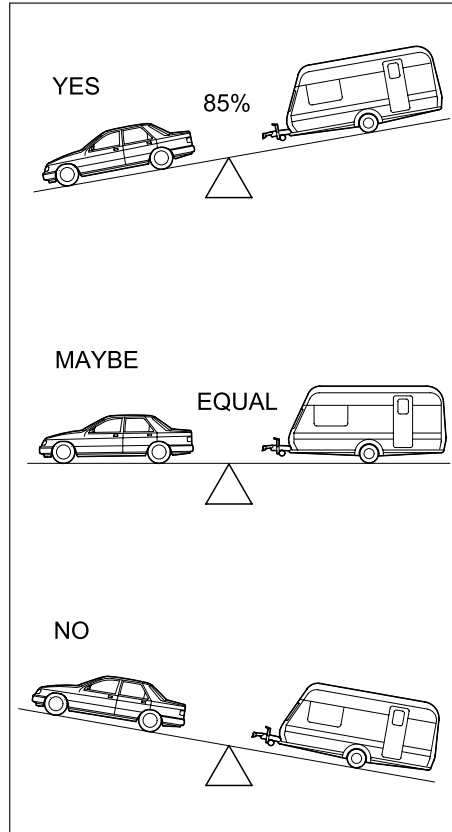

MEASUREMENT OF NOSEWEIGHT

Towing noseweight should be a minimum of 50kg and heavier for twin axle models. This may be measured using a proprietary brand of noseweight indicator. Such equipment is obtainable at your Lunar Caravan Dealer.

Another simple method is to use bathroom scales under the coupling head with a piece of wood fitted between the coupling head and the scales, of such length that the caravan floor is horizontal with the jockey wheel raised.

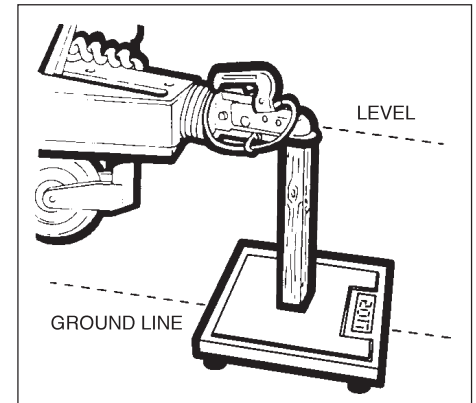



PREPARING FOR THE ROAD

Checklist	8
Loading and Distribution	8
Stability	9
Pre-Tow Checklist	10
Stabiliser	11
Wheel Lock	13
Breakaway Cable	17
Tyres	18



PREPARING FOR THE ROAD

PRE-LOAD CHECKLIST

Caution: Never enter the caravan without first lowering the four corner steadies with the brace provided.

CHECK THAT:

- loose articles are stowed securely. Do not stow tins, bottles or heavy items in overhead lockers prior to towing.
- all lockers and cupboard doors are closed and secured.
- all bunks are secure.
- all rooflights are closed and secured.
- main table is stored in its transit position.
- fridge is on 12v operation and door lock is set.
- all windows are fully closed and latched. Never tow with windows on nightsetting. Leave all curtains and blinds open to aid rear visibility.
- gas cylinders are correctly positioned, secured and turned off.
- battery is secure.
- wheelnuts for tightness.
- tyre pressures and condition of tyres.

LOADING AND DISTRIBUTION OF WEIGHT IN THE CARAVAN

Do not exceed recommended maximum loading for your caravan.

1. Load heavy items low down near the floor and mainly over or in front of the axle(s).
2. Load evenly right to left.
3. Do not load items at the extreme rear since this can lead to instability due to the 'pendulum effect'.
4. Load remainder to give a suitable noseweight at the towing coupling.
5. Check noseweight. (Lunar Caravans are designed to be towed with a minimum noseweight of 50kg and heavier for twin axle models) (See page 4).

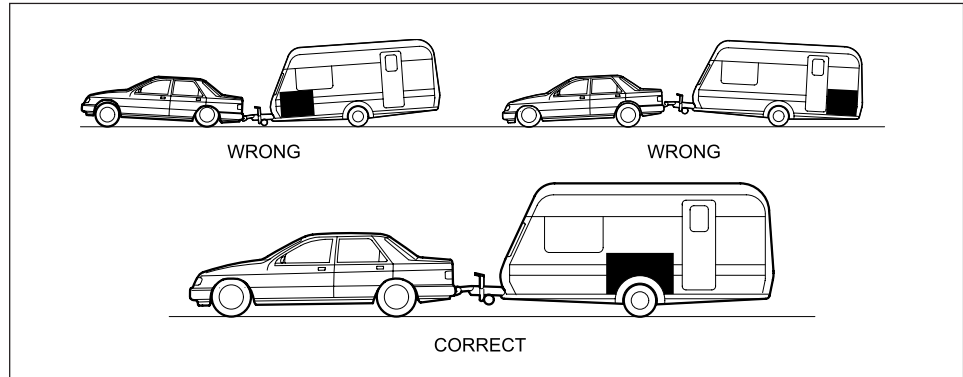
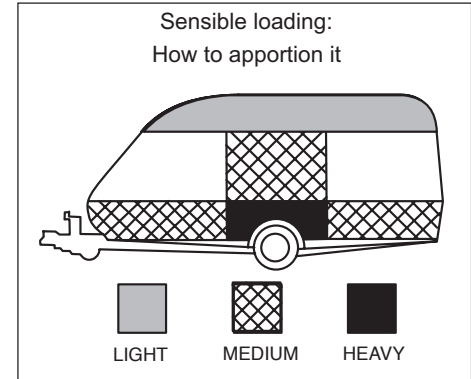

Note: Do not load car boot heavily.



STABILITY

The most common causes of poor stability include:

- (a) Incorrect tyre pressures on car or caravan.
- (b) Worn springs or loose spring fixings on the towing vehicle.
- (c) Towing vehicle shock absorbers too soft.
- (d) Insufficient noseweight.
- (e) Nose of caravan is towing too high.
- (f) Incorrect loading

Stabilisers. There are many proprietary brands of stabiliser available. Your Lunar dealer will be pleased to advise you of the most suitable. They are an aid to stability and should not be considered as a cure for a stability problem.

Note: It is expressly forbidden by the chassis manufacturer for holes to be drilled into the 'A' frame to accommodate a stabiliser bracket. A clamp must be used. Similarly, holes should not be drilled into the coupling head.

Towing vehicle's rear suspension

It is important that the towing vehicle's rear suspension is not deflected excessively by the noseweight on the tow ball. If it is excessive the steering and stability will be affected.

The greater the towing vehicle's tail overhang (the distance between the rear axle and the tow ball) the greater the effect the noseweight will have on the towing vehicle's rear suspension.

After trying out the caravan it may be found that stiffening of the rear suspension is necessary — but note that this may give the towing vehicle a firmer ride when not towing.

There are a number of suspension aids available and advice should be sought on which to use and how to fit.

It is important to ensure that the caravan is towed either level or slightly nose down.

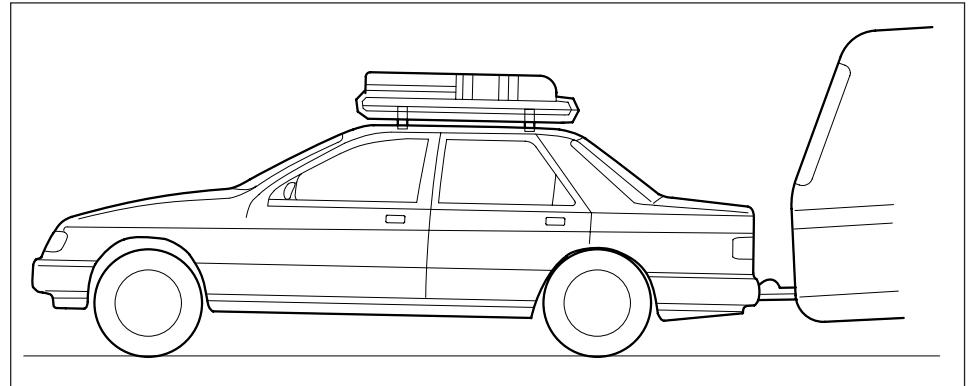

Illustration of excessive deflection of vehicle's rear suspension



PREPARING FOR THE ROAD

PRE-TOW CHECKLIST

1. Check that the hitch is securely coupled onto the towball and connect the breakaway cable. Your hitch height should be around 440mm (17") to the centre of the towball when the towing vehicle and caravan are coupled and laden.
2. The Jockey wheel should be raised and tightly clamped or removed completely if desired.
3. Corner steadies must be wound up fully.
4. Plug in the electrical connection to the car, keeping the cable clear of the road and check the operation of lights.
5. Release the handbrake. "Failure to ensure that the handbrake is completely off, can result in overheating of the brakes and failure of the bearings".
6. Check tyre pressure with cold tyres (see specification). Wheel bolt torque settings should be 88Nm (65lbs/ft) for steel wheels. Alloy wheels should be 115Nm (85lbs/ft).
7. Adjust the tyre pressures of your tow car to the manufacturers recommendations for full loads.
8. Engage the stabiliser, if fitted.
9. Fit towing mirrors to your car.

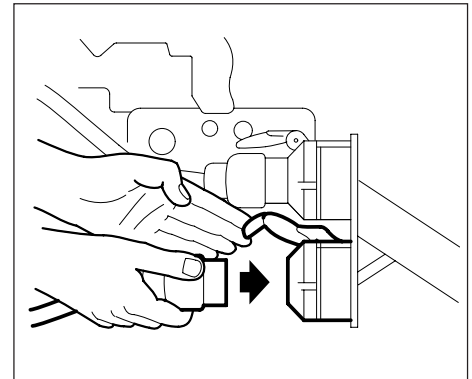
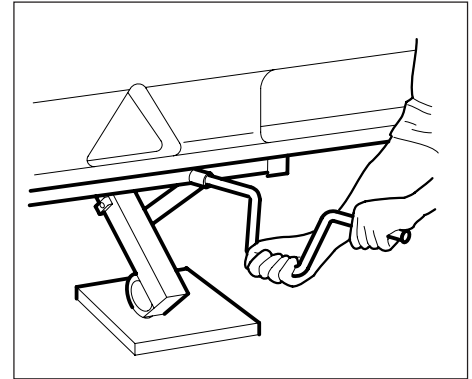
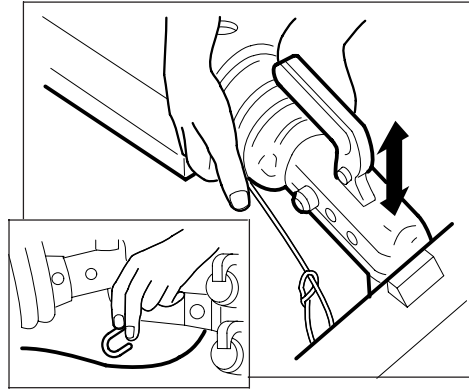



AKS STABILISER (where fitted)

This model of stabiliser has 4 special friction pads, which suppress both snaking and pitching. It is essential that the tow ball is kept completely clean as contaminated pads will reduce its effectiveness.

Operating instructions

- Using the coupling handle, put the AKS on to the towball. Push the black handle down and check the green indicator button is showing (Fig. 1).
- Press the red stabilising lever down. The AKS is now ready for the road (Fig. 2).

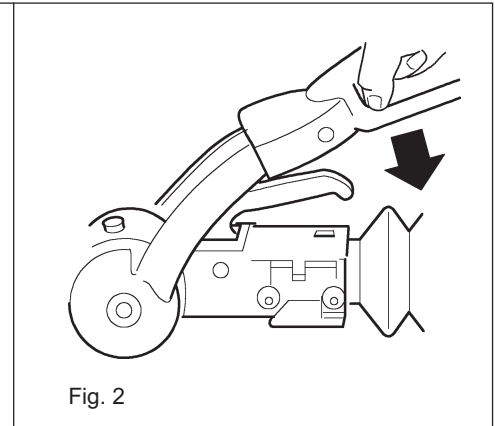
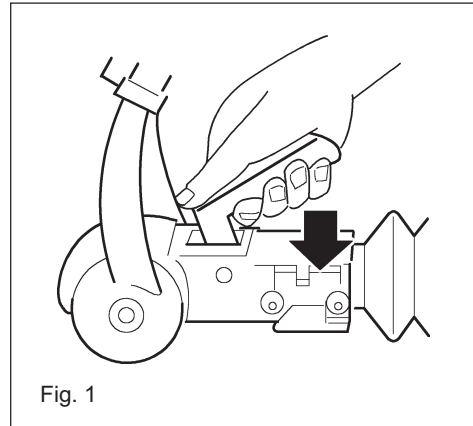

Safety indicators

If the green indicator is visible then you know you have correctly coupled your AKS to your towing vehicle (Fig. 3).

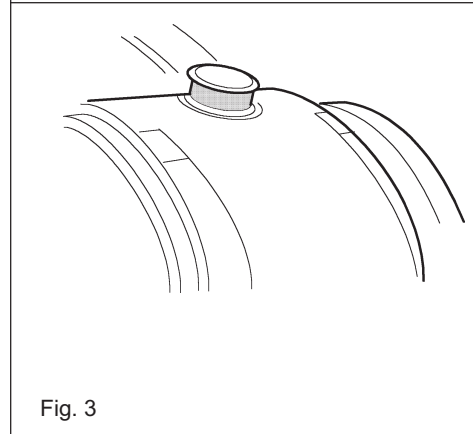

Wear Indicator

For Coupling mechanism and front/rear friction pads. (Fig. 4)

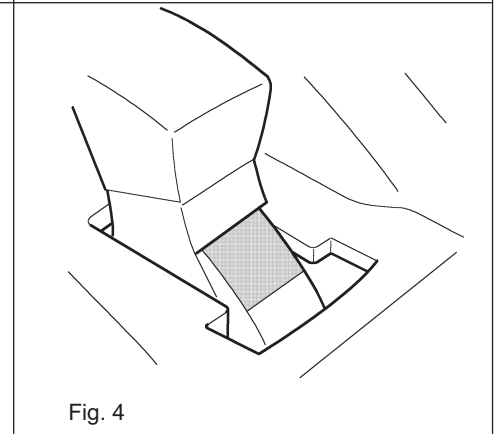



PREPARING FOR THE ROAD

- Wear of the coupling ball and mechanism can be easily monitored. If the green section is visible (when coupled to your towball) then the front/rear friction pads, coupling ball and mechanism are in order.
- If the red lower section obscures the green section then you need to check these parts immediately.

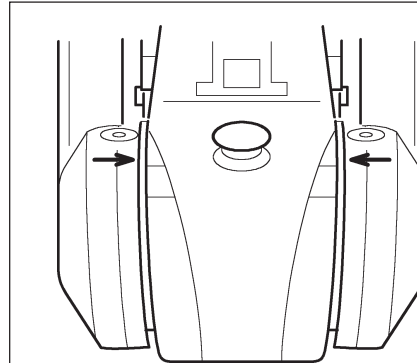
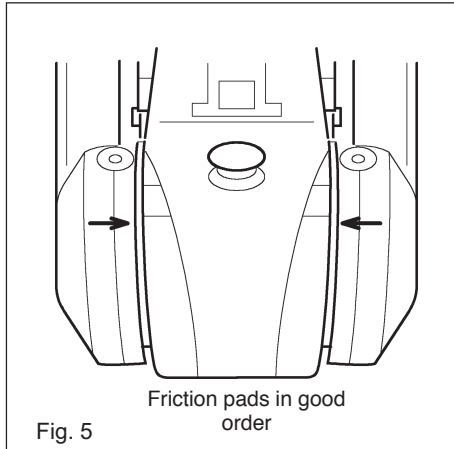

Fig 6 Friction pads worn out and need replacing

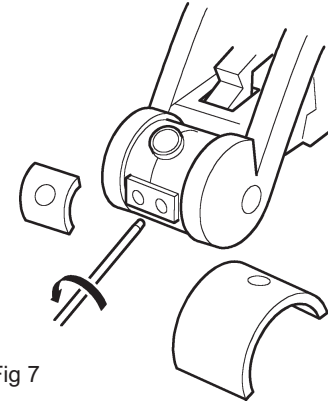

Fig 7

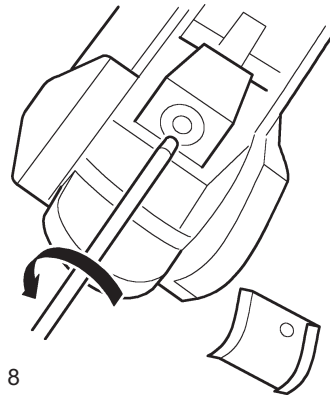

Fig. 8

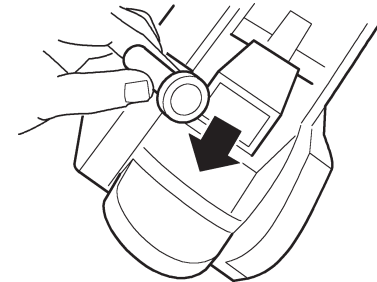

Fig. 9



Friction Pads Replacement

- Unscrew the 2 screws which are under the soft dock by using the special torx tool (UK version only). (Fig. 7)
- Remove screw from back plate. (Fig. 8)
- Remove friction pads. (Fig. 9)

Loading Capacity

The AKS can be utilised to tow vehicles up to a gross weight of 3000kg and a maximum nose load of 100kg.

AL-KO SECURE WHEEL LOCK

You must register your key, should you fail to do this you will not be able to order a spare key or obtain lost or stolen keys.

This is how it works:

- On the Al-Ko Secure registration card you will find an exclusive security number.
- Please register your key by telephoning 0870 7576788 or 0044 1926 818500.
- You will be required to provide the chassis number of the caravan.
- You will need to provide us with a password and supply answers to three security questions.
- Make a note of your password and keep it in a safe place.
- Also keep your registration card safe.
- Take your registration card with you when you are travelling with the caravan.
- Always keep your registration card separate from the lock.

Safety Information

- Always secure the caravan against movement (chock the wheels, couple to towing vehicle).
- Never leave Secure parts (key, locking bolt, registration card) in the caravan.
- Always remove Al-Ko Secure before moving the caravan.
- After any attempt at theft has been made on a locked Al-Ko Secure, the caravan must be inspected in an Al-Ko Approved Service Workshop.
- Always keep the key in a safe place.
- Keep the lock set and registration card separate from the keys.
- The lock parts and key do not have a registration number, therefore keep the registration card in a safe place.
- Caravans with twin axles have two locks, keep each lock set in a separate place. The sets are not interchangeable!

Note: Read the operating instructions and act in accordance with them. Keep the operating instructions for general use. Follow the safety instructions as well as the warning information.



PREPARING FOR THE ROAD

ASSEMBLY

We recommend the use of a side-lift jack for easier fitting of AI-Ko Secure when used on a tandem axle caravan. (Order No. AI-Ko Jack Set 1389235).

- Align the wheel so that the receiver can be seen in the centre of the rim opening. **DO NOT** use the rim opening in which the tyre valve is fitted. (Fig. 1)
- Unscrew the plastic cap from the receiver and store in the tool kit box. (When AI-Ko Secure is not in use, always screw the plastic cap in place). (Fig. 2)
- Insert the locking bolt into the rim specific insert. (Fig. 3)
- Insert the locking bolt socket key. (Fig. 4)
- Line up the locking bolts and assembly with the receiver. (Fig. 5)
- Tighten the locking bolt socket using the wheel spanner provided (or torque wrench as shown) to wheel torque. (Fig. 6)
- Remove the locking bolt socket key. (Fig. 7)
- Insert barrel lock. (Fig. 8)
- Hold the lock fast and lock. (Fig. 9)
- The AI-Ko Secure is now fitted. (Fig. 10)

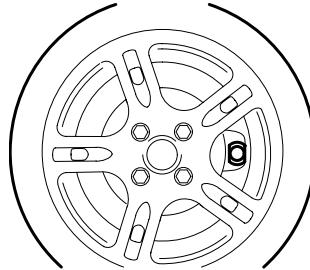

Fig. 1

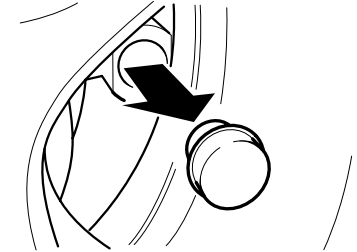

Fig. 2

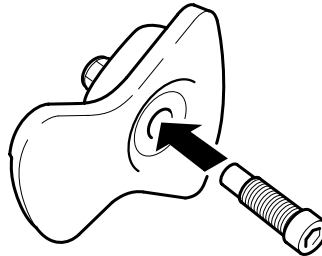

Fig. 3

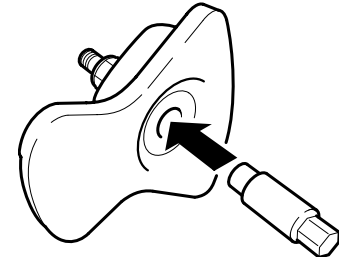

Fig. 4

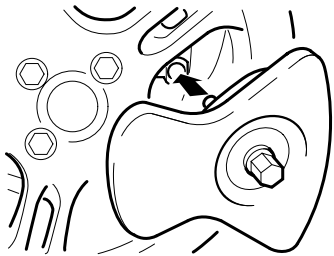

Fig. 5

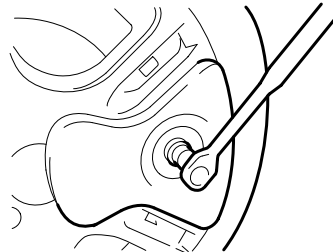

Fig. 6

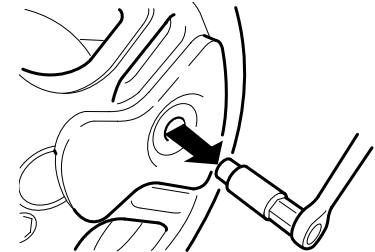

Fig. 7

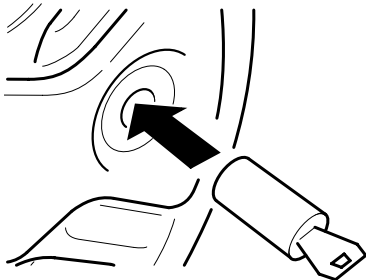

Fig. 8

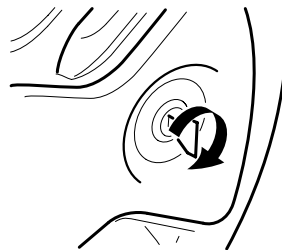

Fig. 9

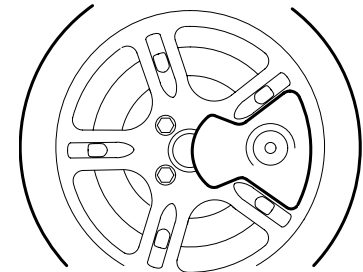

Fig. 10



PREPARING FOR THE ROAD

TWIN AXLE CARAVANS

Fit the front lock first by aligning the wheel so the receiver can be seen in the centre of the rim opening. Chock front wheel and opposite wheel. Jack the caravan (preferably using the Al-Ko side lift jack) until the rear wheel is clear of the ground. Fit the second lock by aligning the wheel as described previously

Note: Lost components phone 0044121 5050400.

In the event of attempted theft report to police and your insurance company.



SECONDARY BRAKING CABLE (Break away device)

Purpose - To apply a trailer's brakes if it becomes separated from its towing vehicle. Having done this, the cable assembly is designed to part, allowing the trailer to come to a halt away from the towing vehicle.

Construction - A thin steel cable, possibly plastic coated, and fitted with a means of attachment for connection to the towing vehicle.

Operation - In the event of the main coupling of the trailer separating from the towing vehicle, the cable should be able to pull tight, without any hindrance, engaging the trailer's brakes.

NOTE: The breakaway cable should never become taut during normal use.

Correct procedure for use:

- Regularly check the cable and clip for damage. If in doubt, contact your dealer or service agent.
- Make sure the cable runs as straight as possible and goes through a cable guide underneath the trailer coupling.
- Determine whether or not the towbar has a designated attachment point (i.e. a part specifically designated by its manufacturer for a breakaway cable).

Where a designated attachment point is provided on the towbar:

Either:

- Pass the cable through the attachment point and clip it back on itself (Fig 1).

Or:

Where no designated attachment point has been provided on the towbar:

Fixed ball - Loop the cable around the neck of the towball. If you fit the cable like this, use a single loop only. (See Figs. 2 and 3).

Detachable ball - You must seek guidance on procedure from the towbar manufacturer or supplier.

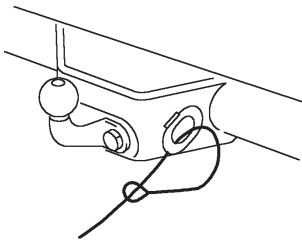

Fig 1

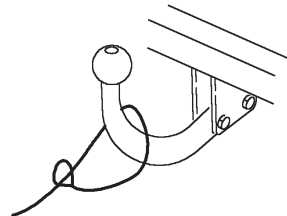

Fig 2

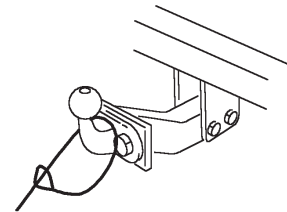

Fig 3



PREPARING FOR THE ROAD

Other means of attachment:

In some instances it may be possible to attach the cable assembly:

Either:

- a) to a permanent part of the towbar structure, as long as this meets the approval of the towbar manufacturer/supplier,

Or:

- b) to an accessory sold for the specific purpose of breakaway cable attachment.

When the breakaway cable is attached, check to ensure:

- a) that the cable cannot snag in use on the trailer coupling head, jockey wheel, or any accessory, e.g. a stabiliser, bumper shield, cycle carrier, etc.
- b) that there is sufficient slack in the cable to allow the towing vehicle and trailer to articulate fully without the cable ever becoming taut and applying the brakes.

NOTE: For peace of mind you might wish to check the state of the cable by positioning the trailer and towing vehicle at extreme angles before setting off.

- c) that it is not so slack that it can drag on the ground. If left loose, the cable may

scrape along the ground and be weakened so that it subsequently fails to do its job. The cable may also be caught on an obstacle when in motion thus engaging the trailer brakes prematurely.

Having followed this advice, should you feel that a satisfactory coupling arrangement cannot be achieved, consult your trailer or towbar supplier or service agent.

- It is a legal requirement that the secondary break away cable is used when towing.

WHEELS

Check wheel nut torques regularly and particularly before a long trip for extra safety.

This service is available at all tyre service depots (inform them of the torque settings)

- The torque settings are:

ALLOY WHEELS	115Nm
STEEL WHEELS	88Nm
- Check wheel/tyres for signs of deterioration or damage.

WARNING: After a wheel has been refitted, always recheck the torque after 20-30 miles use or 20-30 minutes travelling. Even if properly torqued up, it is occasionally possible for fixings to loosen should the wheel "bed in" on the hub.

TYRES

All tyres used on Lunar caravans, when inflated to the pressures recommended, are adequate for speeds up to 130 kph at the maximum specified laden weight of all models.

Note: Maximum permitted speed in the U.K. is 60 mph and in the interests of road safety speeds above this are not recommended.

Tyre tread

A caravan is subject to the same criteria applied to car tyres, namely; a minimum of 1.6 mm tread pattern depth throughout.

Tyre pressures

Caravan and towing vehicle tyres must be at the pressures recommended for towing or heavy loading. The pressures can be found in the towing vehicle handbook and under the caravan specification in the service handbook.

Note: Pressures should only be checked when the tyres are cold, not after a journey or if the vehicle has been standing in the sun.

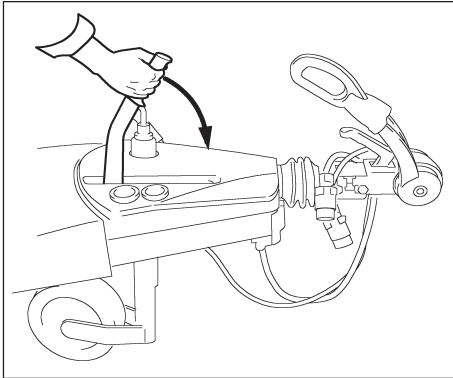

To release the handbrake, push it forward and down using your body weight.

Note: “Failure to ensure that the caravan handbrake is completely off, can result in overheating of the brakes and failure of the bearings”.

Ground Clearance

Care has to be taken to prevent grounding of the caravan when traversing ramps and ground obstacles. If necessary ground clearance can be increased by removing the jockey wheel when travelling.

Number Plate

A trailer must carry a rear number plate bearing the number of the towing vehicle and be illuminated at night. The number plate should conform to the same size and colour regulations as for cars. A reflective black and yellow plate may be used on a trailer towed by a vehicle with non-reflective plates and vice-versa.

Manoeuvring

When pushing or pulling the caravan always use the grab handles correctly, do not snatch them and never push body panels, metal or glass reinforced plastics, as this can cause serious damage to the bodywork or mastic seals.

Mirrors

The driver of the towing vehicle must have an adequate view of the rear.

If there is no rear view through the caravan it is essential that additional exterior towing mirrors are fitted.

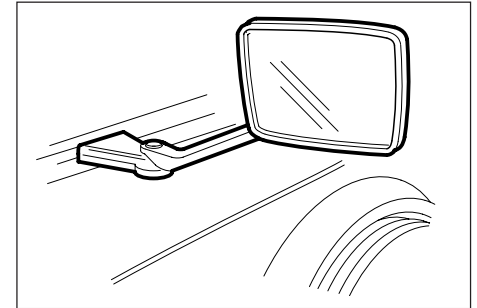

Caution: Any rear view mirror must not project more than 200mm outside:

- the width of the caravan when being towed.
- the width of the towing vehicle when driven solo.

Note: Any rear view mirror fitted shall be ‘e’ marked and cover the field of view as stipulated by type approved requirements (Regulation 33 of the Road Vehicles [Construction and Use] Regulation 1986).



PREPARING FOR THE ROAD

Road lighting

For your information the wiring diagram of the 13 pin connector is shown. These should be checked regularly and if in any doubt a qualified electrician consulted.

Passengers

Passengers are forbidden to ride in a caravan with the exception of authorized test personnel.

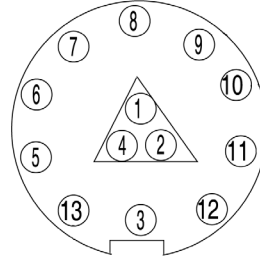

PIN No	COLOUR	DESCRIPTION
1	YELLOW	LEFT IND
2	BLUE	FOG
3	WHITE	NEG FOR ROAD LIGHTS
4	GREEN	RIGHT IND
5	BROWN	RIGHT SIDE LIGHTS
6	RED	STOP
7	BLACK	LEFT SIDE LIGHTS
8	ORANGE	REVERSE
9	BLUE/BROWN	CAR +VE
10	RED/BROWN	FRIDGE +VE
11	GREEN/WHITE	FRIDGE -VE
12	EMPTY	
13	BLUE/WHITE	CAR -VE

13 pin plug wiring diagram

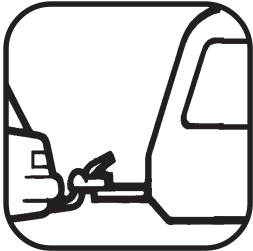

ON THE ROAD

- Speed Limits 22
- Pulling Off 22
- Caravan Handling 22
- Motorway Driving 22
- Reversing 22
- Changing a Wheel 23
- Jacking Points 23
- Stopping on a Hill 24
- Arrival on Site 24



ON THE ROAD

SPEED LIMITS

Normal road towing: 50mph

Motorways (including dual carriageways): 60mph

PULLING OFF

Let the clutch in smoothly.

Allow more engine speed to produce the power to move the additional weight of the caravan.

Avoid wear and tear on clutch and transmission by taking extra care.

Change gears smoothly.

Try not to jerk the clutch.

CARAVAN HANDLING

Allow for caravan being wider than car.

Do not bump kerb with caravan wheels.

When passing other vehicles allow more than the normal clearance for driving solo.

Allow longer to get up speed to pass.

Allow for the vehicle being twice its normal length.

Do not suddenly swing out.

Carry out all manoeuvres as smoothly as possible.

Use nearside wing mirror to check caravan has cleared when overtaking.

Never let a 'tail' of traffic build up behind you. Always pull in to let others past.

MOTORWAY DRIVING

1. Caravans may not be towed in the outside lane of a three or four lane motorway. (Reg. 12(2) of the Motorway Traffic [England and Wales] Regulations 1982).
2. Reduce Speed:
 - i) In high or cross winds.
 - ii) Downhill.
 - iii) In poor visibility
3. High sided vehicles cause air buffeting so extra care must be taken when passing or being passed. As much space as possible should be given.

Reversing

Proficiency at reversing can only be achieved with practice and should be first attempted in a large open area.

Your caravan is fitted with an automatic reversing mechanism which allows you to reverse without the need to make any adjustments. **After reversing, the caravan should be drawn forward at least 1 metre to restore the brake shoes to their normal position before applying the hand brake.**

Note: Reversing uphill will be difficult if either wheel brake or brake linkage is overadjusted. You need to ensure that the brakes have been disengaged before reversing uphill.

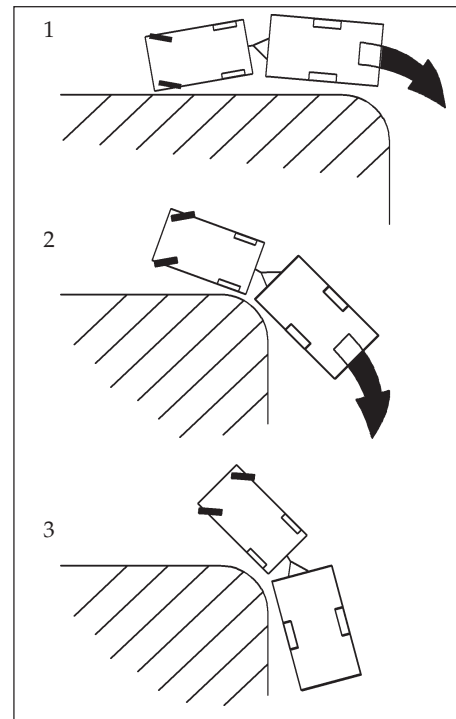

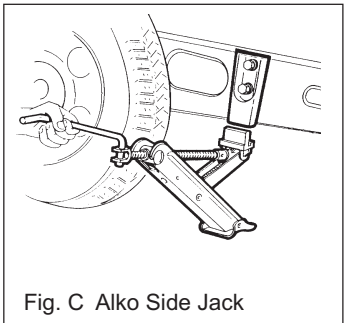
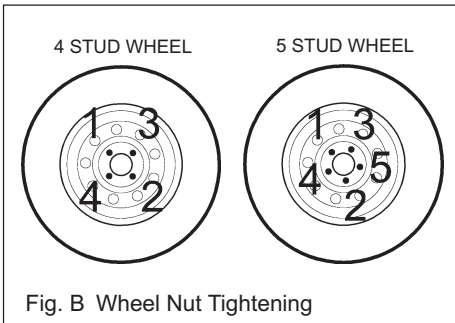
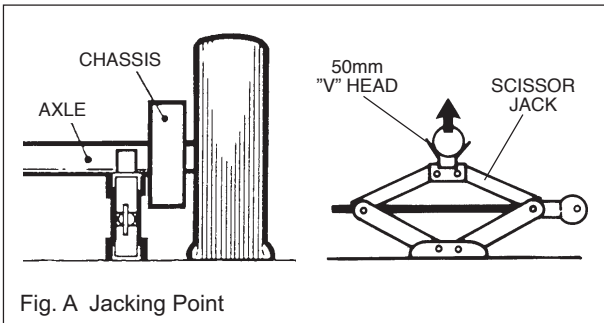

CHANGING A WHEEL

1. Leave caravan hitched to towing vehicle and ensure handbrake is applied.
2. Lower corner steadies (as safety measure) on the side that the wheel is being changed to stabilise the caravan.
3. Use wheel brace to slacken off wheel nuts on the wheel to be changed.
4. Position jack under the axle at the appropriate jacking point (see fig. A).
5. Jack up the caravan until the wheel for removal is just off the ground.
6. Remove the wheel bolts, wheel trims and remove the wheel.
7. Fit spare wheel and reverse the above procedure.
8. When replacing the wheels you should tighten the nuts in rotation diagonally. Tighten all nuts equally, according to Fig. B, to 88Nm (65 lb/ft)

for steel wheels and 115Nm (85lbs/ft) for alloy wheels using a torque wrench or have checked as soon as possible.

Note: When changing a wheel ensure:

- a) that the correct wheel fixings are used.
- b) that there are clean, dry mating surfaces and clean, dry bolt/nut area.

NB: Special nuts are supplied with alloy wheels and these can be used where a steel wheel is used as a temporary spare.

If replacing an alloy wheel nut, a nut to the following reference should be purchased: M12 x 1.5 pitch, 26mm thread, 10.9 grade, 60 degree conical fixing, 19mm hexagon bolt head.

IMPORTANT

When a wheel has been removed and replaced the torque of the wheel nuts should be re-checked after approximately 15 miles of running.

JACKING POINTS

It is recommended that the jack is located in the correct position i.e. on the axle tube inside the chassis member (Fig. A). The reinforced axle mounting plate can be used as an alternative but the chassis-member itself **MUST NEVER** be used as a jacking point.

Alko Side Jack

The Alko chassis is provided with the facility to fit an Alko side jack which can be fitted as an optional extra (Fig. C).



STOPPING ON A HILL

Pulling off again can sometimes present a problem. The easy solution is:

- (i) Carry a good sized wedge shaped piece of wood with a rope or light chain attached.
- (ii) Attach the other end of the rope to the nearside rear grab handle.
- (iii) Place the wood behind the nearside caravan wheel.
- (iv) Carefully reverse the car slightly back down the hill, the caravan will stop against the wedge and turn.
- (v) Drive forward since this attempt to move up the hill will now not involve pulling the full weight of the caravan until the car has gained some traction.

Ramps

Take care to prevent fouling when traversing ramps or other ground obstacles.

ARRIVAL ON SITE

Note: Check and observe site regulations.

1. Selecting a pitch.

Do not pitch in such a position that your outfit will obstruct others coming in.

Try to choose an area which is dry, reasonably level and preferably with a hard base.

If you have no alternative but to pitch on a slope ensure that, for when you leave, you are facing down the slope.

It is good practice to chock the wheels of the caravan when parked on a slope even though the caravan brakes are applied.

2. Siting/Unhitching

When you arrive at your site and have been allotted a pitch:

Manoeuvre your caravan onto your pitch (if you have reversed read the notes on page 20), apply the handbrake, remove the brake safety cable, unplug the 13-pin plug and store these in the sockets provided on the 'A' frame cover.

Unclamp and lower the jockey wheel to the ground. Re-clamp the jockey wheel after first unscrewing slightly.

Free the coupling by winding up the coupling head until it is clear of the 50mm ball. Replace the tow ball cover and then park your car.

3. Levelling the caravan

Levelling must be carried out in both directions in order for the refrigerator and other equipment to function correctly.

The positioning of the jockey wheel can be used to help level the caravan.

Lower the corner steadies until they are in firm contact with the ground. DO NOT use the steadies as a jack they are only a means of stabilising the caravan.

Levelling pads or boards should be used under the steadies where the ground is soft or uneven. Stepped levelling boards can easily be constructed (Fig. D).

In extreme cases where it is necessary to raise a wheel off the ground for levelling purposes, further adequate support should be applied so that the steadies do not take any undue strain.

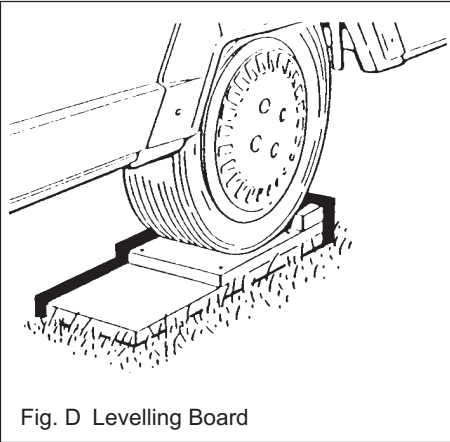

Fig. D Levelling Board

Exterior Door

To prevent distortion of the body, the caravan must be always correctly sited and levelled. Failure to site the caravan correctly may prevent the exterior door from closing properly.

Attention: Always disconnect the electrical connector between the towing vehicle and the caravan before connecting an LV supply to the caravan and before charging the caravan battery by any other means.



**FIRE
&
SAFETY**

- In Case of Fire 28
- Smoke Alarm 28
- Fire Extinguisher 29
- Children 29
- Ventilation 29
- Security 30
- Theft 30
- Chassis Number 30
- Additional Security 30
- Datachip Security Card 30



FIRE & SAFETY

FIRE ACTION

1. GET EVERYONE OUT
2. TURN OFF GAS VALVE
3. RAISE THE ALARM AND CALL THE FIRE BRIGADE
4. DISCONNECT THE MAINS ELECTRICITY SUPPLY
5. TACKLE THE FIRE IF SAFE TO DO SO
6. MAKE YOURSELF FAMILIAR WITH THE INSTRUCTIONS ON YOUR FIRE EXTINGUISHER AND THE FIRE PRECAUTION ARRANGEMENTS ON THE SITE
7. CHECK FIRE EXTINGUISHERS REGULARLY
8. CHECK GAS PIPING AND MAINS ELECTRIC WIRING ANNUALLY

If you suspect a gas leak - never use a naked flame to search - always use soapy liquid or - better still - call your caravan dealer.

Important

With any extinguisher, never use it on a pan of fat - this is very dangerous - always use a fire blanket.

To tackle a pan fire: First of all, if possible try to turn off the gas. Make sure you are aware of the position of the gas isolating taps - usually placed in the sink unit cupboard.

Never throw a flaming pan outside, keep your hands away from the flames and smother the flame.

Try to remain calm.

Do not throw the blanket on the fire but place over the pan paying particular attention to the handle.

Fire Precautions

Make sure you are aware of the operation and location of escape windows and doors.

It is advisable to carry a fire extinguisher (a dry powder is recommended) positioned as near to the exterior door as possible.

A fire blanket approved to BS 6575 is also advisable positioned as near to the cooking area as possible.

Check the fire regulations on arrival at sites. Do not leave pans on the stove unattended. Do not leave matches within easy reach of small children.

Never leave small children alone in the caravan.

Do not smoke in bed.

Do not block up ventilators.

SMOKE ALARM

The Code of Practice requires that a smoke alarm is fitted in your caravan. Every new

manufactured caravan has a smoke alarm fitted as standard equipment.

Connecting the battery

Your alarm requires one 9 volt battery to power the smoke detector portion of the unit. Under normal use, the battery powering the smoke detector should last approximately one year. See label inside smoke alarm lid for suitable batteries.

With a pencil, write the date of battery installation on the inside of the cover to remind you when to replace the battery.

Lift battery from battery holder and snap battery connectors to battery. They fit together only one way.

Gently push battery into battery holder.

To close the cover match up snap-in hinges and gently press together until base and cover snap together.

IMPORTANT

When the battery is first connected the alarm may sound for 2-3 seconds.

THIS IS NORMAL.

It means the battery is connected correctly.

Replacing the battery

Test the alarm for correct operation using the test button whenever the battery is replaced.



When battery power is low and replacement is necessary, the alarm will 'beep' about once per minute for at least 30 days. The battery must then be replaced. Replace battery if the alarm does not sound when the test button is pressed. For maximum reliability, replace battery at least once a year.

Testing the Smoke Alarm

It is recommended that you test the smoke alarm once a week to be sure the unit is working. It will also help you and your family to become familiar with the sound of the alarm.

When you press the test button it simulates the effect of smoke during a real fire. So, there is no need to test the alarm with smoke.

Press and hold the test button until the alarm sounds (it may take up to 10 seconds). The alarm will stop sounding shortly after the button is released.

Cleaning the Smoke Alarm

Clean the smoke alarm regularly. Use a soft bristle brush or the brush attachment of your vacuum cleaner to remove dust from the sides and cover slots where the smoke enters. Keep cover closed while cleaning. Do not vacuum or brush inside the smoke alarm. To clean the cover, remove it completely and use only mild soap and water. Dry cover thoroughly before replacing it.

Warning: Do not paint the Smoke Alarm.

Other than the maintenance and cleaning described above, no other customer servicing of this product is required.

Fire Extinguisher

It is recommended that a 1kg (2lb) minimum capacity dry powder fire extinguisher be carried inside your caravan at all times. (NCC recommend types marked 5A34B).

When using a dry powder extinguisher it is suggested that the caravan be evacuated until the powder has settled, to avoid inhalation.

A fat pan fire should not have a fire extinguisher aimed at it. It should be smothered with a fire blanket.

Children

Do not leave children alone in the caravan in any event. Keep potentially dangerous items out of reach, as at home e.g. matches, drugs etc.

Bunks

Where fitted, the foldaway bunk has been tested to 70kg (11 stones) and has a recommended limit of 57kgs (9 stones). Safety features are included but care should always be taken, particularly if the child is under 3 years of age. Bunks are not suitable

for children under 6 years old without supervision.

Solid (fixed) bunks have a recommended limit of 75kg (12 stones).

Ventilation

All caravans comply with British Standards EN1645. The ventilation points on your caravan are fixed points of ventilation which are stated by the British Standards. Ventilation is provided at floor and ceiling level and care should be taken to ensure these remain clear of debris by regular cleaning.

Under no circumstances must these vents be blocked or obstructed.

It is advised that fixed ventilation points are checked and cleaned (if necessary) on a regular basis.

Additional night time ventilation is obtained by releasing the window catches and placing them in the second groove on the frame catch.

You must maintain adequate spacing of combustible materials from sources of heat (eg heater)

Do not use independent gas appliances inside the caravan.

We advise that the user instructions for the fitted appliances are studied in addition to the information in this handbook.



FIRE & SAFETY

Petrol/Diesel Fumes

The fitting of a tail pipe to your car exhaust will reduce the possibility of fumes entering your caravan through the front fixed ventilation points.

SECURITY

Caravan theft

The theft of a caravan can occur in the most unlikely circumstances; from a motorway service area, even from an owner's driveway.

Secure all windows and doors when your caravan is unoccupied even if only for a short length of time.

Vehicle Identification Number (V.I.N.)

Record your caravan V.I.N. which can be found on **any of the eye level windows**.

Make a note of this number in the space provided at the front of this handbook and make separate note of the number to keep safe at home.

Additional security

Consider fitting any device which might deter or prevent intrusion by thieves.

A hitch lock cover helps to prevent towing of the caravan.

A wheel lock prevents towing of the caravan and removal of the wheel.

Customers are advised to identify their caravan with a method for subsequent identification if other forms of identification have been altered or removed.

Free crime prevention advice about securing your caravan, protecting your valuables, property marking, either at home or whilst on site, can be obtained from the Crime Prevention Officer through your local Police Station.

Datachip Security Card

Each model has a datachip security card concealed within the body of the caravan, showing the VIN.



SERVICES

Water	32
Gas	39
Electricity	43



SERVICES

WATER SYSTEM - DELTA MODELS

An underfloor water tank with an approximate capacity of 40 litres of fresh water is fitted as standard equipment on the Delta models only. Water levels are displayed by a series of LED's on the control panel. The tank has its own in-built pump and filling of the tank via the external pump supplied, which is operated by a switch on the control panel.

Full switching operation for the pumps can be found under Delta control panel.

Due to weight and stability we recommend that the tank is drained prior to towing.

DO NOT ALLOW ANY OF THE PUMPS TO BE ACTIVATED WHEN NO WATER IS PRESENT AS THIS WILL DAMAGE THE PUMP.

The tank is fitted with an overflow and a drain cock.

Do not use bleach or detergents for cleaning the system but rather a formulation from your chemists normally used by home brewers.

WATER SYSTEM WITH UNDERFLOOR WATER TANK - DELTA MODELS

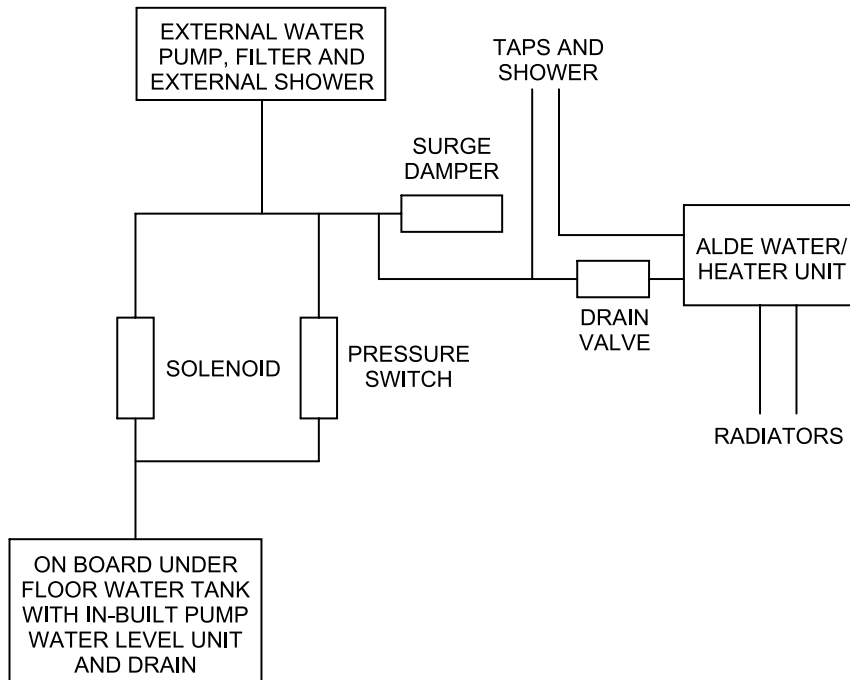



STANDARD WATER SYSTEM

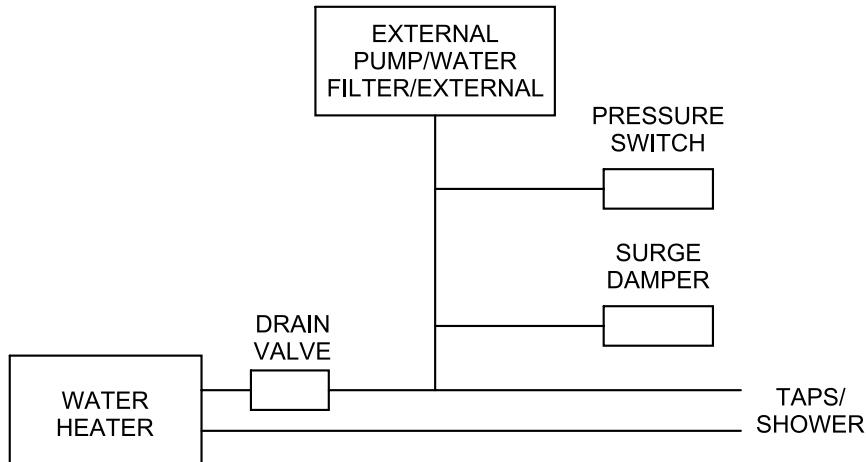

Whale Surge Damper

The surge damper prevents water hammer and also reduces switch hunting on and off.

The surge damper is a completely sealed unit and requires no servicing, however, as with Whale water systems, the complete system should be drained in the winter.

The Filter

The filter attaches directly to the pump and incorporates a non- return valve designed to prevent dirt and grit from entering the pump valves as this will cause pump failure. The filter is fitted during installation to protect the pump.

Pressure Switch

The pressure switch is operated by the opening and closing of the taps/shower. When a tap is opened the pressure in the system is altered which activates the pressure switch supplying power to the selected pump.

Solenoid

The solenoid is an electrically operated valve controlling the water flow from internal and external pumps.

Maintenance

Poor pump performance may be an indication that the filter has become blocked



SERVICES

by debris. The filter is easily removed for inspection and cleaning:

- Remove circlip and unscrew filter from pump.
- Pull two halves of filter apart to expose the strainer mesh.
- Remove any debris and replace strainer mesh in position.
- Ensure the rubber seal is correctly seated in the groove on the outlet side of the strainer before pushing the two halves firmly together.
- Attach to the pump and replace the circlip.
- See arrow on pump housing for flow direction.

Care of your Submersible Pump

Care should be taken to ensure that the pump is not allowed to run dry for appreciable periods. Whilst the design will allow some dry running, such as when the tank requires refilling, the pump life will be appreciably lengthened if care is taken to minimise dry running.

Aquaflow Caravan Filler

There is a special filler fitted for use with the Submersible Pump which not only provides a recessed, locking filler cap for water input, but also a polarised power take-off point complete with input plug. This is part of the original equipment for Delta models only.

The Water System for Delta Models

A submersible pump is used for pumping water from an external container into the inboard tank of the caravan.

To Operate The System

First ensure that the drain tap on the inboard tank is closed. Place the pump inside your filled container. Place the hose into the filler cap on the side of the caravan. Plug in the 12 volt plug into the socket on the filler cap. When the water container is empty unplug the 12 volt - do not allow the pump to run dry.

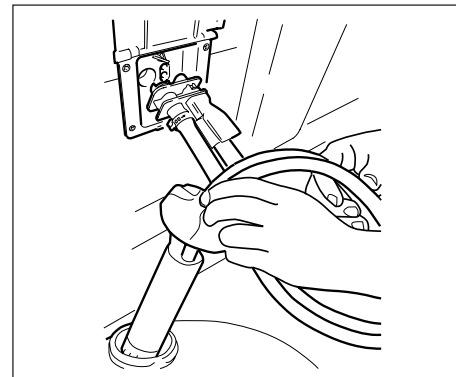

WATER PUMP

The separate plug-in pump assembly consists of a Crystal Maxi pump, hose and plug. The plug provides connection of both water supply to the caravan and 12V dc electric power to the pump. A dust cover is fitted to the connecting dual hose to prevent contaminants falling into the water container.

The Crystal Maxi pump is a completely sealed unit designed for intermittent use. It is NOT self-priming and therefore to ensure proper performance, the pump **MUST ALWAYS** be fully submersed in water **BEFORE** plugging into the wall socket.



Initial connection to fresh water supply

1. Fill the fresh water container and place it alongside the wall socket located in the offside external wall of the caravan.
2. Ensure the pump isolator switch at the control panel inside the caravan is switched off.
3. Open the 'hot' kitchen tap. Ensure all other taps are closed.
4. Place the pump into the water container outside the caravan, taking care to ensure the pump reaches the bottom of the container.
5. Lift the lid of the wall socket and fit the pump assembly plug into the socket. Ensure it is pressed in fully.
6. Adjust the dust cover to fit over the opening in the water container to keep contaminants out.
7. Switch on the pump isolator switch at the control panel inside the caravan.
8. Wait until water flows freely from the 'hot' kitchen tap. Allow to flow for a few more seconds to ensure release of any trapped air in the water system, then turn the tap off.

Repeat the same procedure with the 'cold' kitchen tap.

If the system has been drained, the above procedure **MUST** be repeated **EVERY** time the water container is filled.

Switch on the pump isolator at the control panel.

Once it has been properly connected, and a tap is turned on, the pump is activated automatically by a micro switch in the Zeniths only; a pressure switch in all other models.

Fault Finding

1. *Pump runs very noisy but does not pump water.* Likely to occur after water container has been refilled. Pump is air locked. *Cure:* unplug from socket allowing pump to flood, and reconnect by plugging in again. The correct sequence when refilling the container is to unplug, replace pump in container, then reconnect.
2. *Pump fails to deliver water.* The most likely cause will be air in the system. To remedy this, switch off the pump and shake the pump assembly in the water. Then switch on again. Alternatively, make sure the assembly is positioned fully into the housing.
3. *Pump does not run at all.* If not due to blown fuse or faulty connections, then most likely cause is excessive continuous running. *Cure:* replace pump.

Never allow the pump to run dry.

Never allow the pump to run continuously for more than 15 minutes.

Note: When refilling the water container, the pump assembly may be left plugged into the wall socket so that the pump can be kept off the ground by inserting the hose into the groove on the underside of the plug. But, the pump assembly **MUST** be unplugged **BEFORE** replacing the pump into the refilled water container.

STERILISING

When cleaning the water system at the start or the end of the season, it is advisable to use the sterilising fluid, e.g. Milton 2, Chempro SDP or similar. It is recommended that for this operation you use any empty filter body as the fluid reduces the effectiveness of a new filter.

Flush the system thoroughly to remove the effective fluid traces.

After sterilising the system at the start of the season it is recommended that a new filter cartridge is fitted.

NOTES

- Never allow the pump to run dry. Always ensure that the pump is submerged in the water or the life of the pump will be reduced.
- Before winter storage, the water system must be completely drained.
- Clean the water system at the start and



SERVICES

end of the season with sterilising fluid (see notes under sterilising).

Water System Winterisation

Caravans may be in use all year round, but when not in use, even for short periods, this procedure should be followed. One night of freezing temperatures is all that is required for expensive permanent damage to water system components.

- a. The whole system must be drained.
- b. Open kitchen taps. Lever taps should be lifted in central position, leave taps open permanently after system drain down.
- c. Open bathroom and shower taps (including shower on/off control rose) and leave open permanently after system drain down.
- d. Shake the shower head to remove the water held there and in the hose. At this point it is recommended to remove the shower head from the hose. Even the smallest amount of frozen water can result in the shower head cracking.
- e. Remove cold water drain plug (if fitted), normally located under the caravan near to the water inlet socket.
- f. If possible remove any remaining water from system plumbing at water inlet sockets and in between in-line pressure switch plumbing.

- g. Disconnect cartridge or in-line filters from plumbing.
- h. Submersible pumps should be shaken out and stored in a dry place.
- i. Drain the external shower bridge connection (including models without external shower) on the Ultraflow housing by inserting the shower connection or open the valve by means of a tool to push on the black rubber pad of the valve.

Cleaning the Water System and Portable Water Tanks

The water systems, and in particular storage tanks, in caravans are susceptible to contamination by bacteria if care is not taken with their use and cleaning. The symptoms caused by bacterial contamination are not purely limited to gastro-intestinal diseases, but may also manifest themselves as ear, nose, throat, eye or skin infections. It is therefore important that you carry out the following procedure prior to using the caravan each time, even if you boil or filter all water you use for drinking.

Water Containers

1. All water remaining in the container should be disposed of so that the container is empty.
2. The outside of the container should be thoroughly cleansed and washed down to

remove any dirt, dust or other contaminants. Water at a suitably hot temperature containing an appropriate detergent is recommended for this purpose.

3. Water should be placed in the container, swirled around, then emptied out.
4. The container should then be totally filled with water containing an appropriate disinfectant/sterilant solution and allowed to stand for the recommended contact time (e.g. Milton for 15 minutes).
5. The solution should be emptied from the container.
6. The opening of the container should be cleaned thoroughly with an appropriate pre-prepared wipe impregnated with a disinfectant/sterilant.
7. The container should be inverted whilst stored overnight (if possible).
8. The container must be filled with mains water only and mains water only should be used for the above cleaning procedure.
9. On no account should garden hoses be used to fill water tanks.

Water Systems

1. Drain down the system. (Open all taps to allow air in, enabling the system to drain quickly.)



2. Remove any water filters fitted, and replace with a short length of hose or empty filter cartridge (this will ensure the filter is not affected by the disinfectant/sterilant solution).
3. Fill the system by using the pump with a disinfectant/sterilant solution. (Check that the solution at full strength appears at all taps/showers). Allow to stand for the recommended period of time.
4. Drain the system down using the water systems internal flip switch located under the front off-side bed.
5. Thoroughly clean the outside of all taps/connectors with a cloth soaked in the disinfectant/sterilant.
6. Flush the system through with clean drinking water until no traces of disinfectant/sterilant can be detected at any tap.
7. Replace the filter.

Suitable sterilising chemicals are available from your caravan dealer, accessory shop, chemists or home-brew shops. It is not, however, recommended to use bleach or sodium metabisulphite.

Setting Up the Water System

1. Replace/close all drain valves.
2. Replace shower heads and tap spouts.
3. Close all taps.
4. Refit old filters:
 - a. Check all plumbing connections.
 - b. It is recommended at this point to sterilise your water container and flush the system through with sterilising fluid.

Note:

Frost damage cannot be claimed under warranty.



SERVICES

PRESSURE SWITCH

Operation

The pressure switch detects the opening or closing of any tap in the system and switches the pump on or off accordingly. It is located near the water heater.

To prime if fitted with a submersible pump:

1. Trapped air in the submersible pump will not allow the pump to prime. Air can be released by gently shaking the pump under water while the pump is in the water tank but is switched off.
2. If an external submersible pump is used, place the pump in the water before connecting to the side of the van.

At normal flow rates the pump should operate continuously — but at low rates the pressure switch will cycle on and off to maintain back pressure in the pipework.

Adjusting the pressure switch:

If the battery voltage is not constant, cycling may occur. This can be minimised by adjusting the switch's diaphragm sensitivity as follows:

1. With the system properly primed, close all taps and showers.

2. Leave the power supply turned on.
3. Tighten the adjusting screw (clockwise). The pump should now be running.
4. Partly open one cold tap to allow water to flow at about 1 pint per 15 seconds.
5. Now slowly loosen the adjusting screw until the switch starts to click. The switch will then be properly adjusted.

Helpful Hints

- a) If the pump will not run:
 - Pump could be faulty or a wire disconnected.
 - Check that the pump isolating switch is turned on.
- b) If the pump cycles on/off:
 - Battery voltage may be too low (at or below 10.5 Volts). Adjust switch (see text) and/or recharge battery.
 - Check for air or water leaks in taps and piping. Re-adjust pressure switch.
 - Non-return valve may be held open by grit.
- c) If a pump motor runs steadily and will not stop:
 - Battery voltage may be too low (at or below 10.5 volts)

- Check all connections in the pipe-work.
- Remove the adjusting screw, if motor still runs, pump is probably air locked. Turn off the isolator switch and reprime the pump (see text).

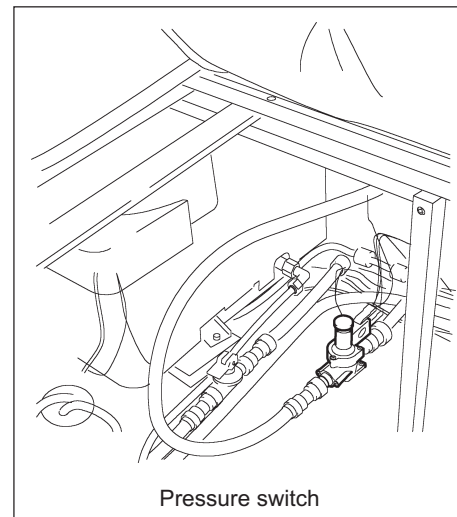

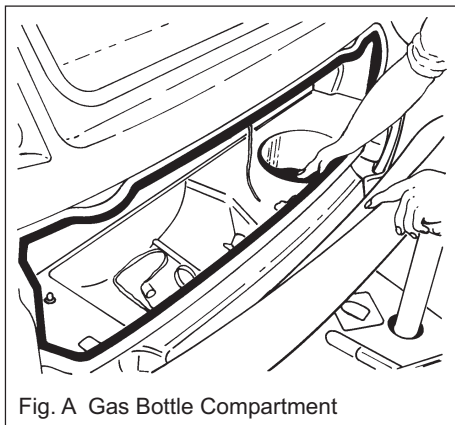

Fig. A Gas Bottle Compartment

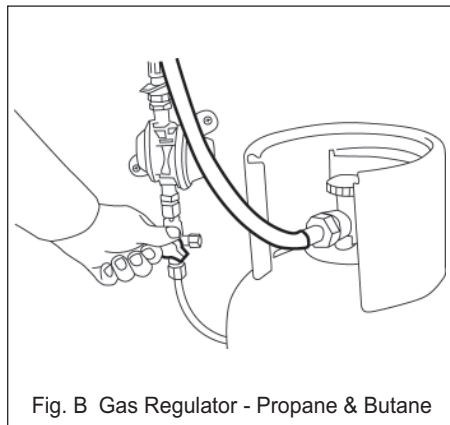

Fig. B Gas Regulator - Propane & Butane

GAS

GENERAL INFORMATION

Gas Bottles

Bottled Liquefied Petroleum Gas (LPG) is the most convenient portable source of fuel for your caravan.

Make sure that heating and cooking appliances and the gas cylinders are switched off before you move the caravan.

Regularly check flexible gas hose, joints and connections for tightness. Finally make sure that each gas appliance is working efficiently to the recommendations of the appliance manufacturers.

In all cases the cylinder contents are in liquid form under pressure from the gas above it, and the pressure is only dependent on the type of L.P.G. and its temperature.

When gas is supplied the pressure in the cylinder is slightly reduced and liquid "boils" off to restore the balance. This action cools the liquid and the cylinder, and condensation or even frost may sometimes be observed on the outside of the cylinder. The cylinder, when in use, is always cooler than the surrounding air so allow plenty of circulation in cool weather and do not cover the cylinder with a "cozy" in the winter.

Butane works satisfactorily at temperatures down to 2° C. Propane should be used for temperatures below this, therefore for all year round caravanners, Propane is of greater use.

There are different sizes of bottles available and it is better to consult your dealer for advice. Gas cannot be supplied from the bottle without an approved regulator.

Hoses connected from regulator to the caravan supply should be made from Neoprene and comply with EN1949. Hoses have a limited life and should be inspected regularly and changed annually.

The gas cylinders have a recess in the gas bottle compartment into which the cylinders should be restrained by means of the straps provided.

If cylinders are used outwith this compartment you must ensure 1) they are adequately supported b) ventilation is not blocked c) damage will not be caused to fixtures and fittings.

Never use a gas cylinder on its side - always stand cylinders upright - keep them in the gas locker provided (Fig. A).



SERVICES

If you should suspect a gas leak turn off the gas at the bottle and ventilate the caravan by opening the door and windows. Do not operate anything electrical and remove everyone from the caravan until the gas has dispersed. It is part of your annual service to inspect all gas pipes and appliances.

Changing a Gas Cylinder

Before commencing to change a gas cylinder ensure that the valve on the cylinder is turned fully off. Turn off all gas operated appliances.

Remove the gas hose from gas cylinder.

Before refitting a gas cylinder, ensure that all gas operated appliances are turned off – particularly after winterisation. Ensure all connections are secure.

The regulator

Your caravan is fitted with a regulator (capacity 1.5kg/hr) as standard equipment (Fig. B). This is located in front gas bottle locker. The gas regulator has a working pressure of 30mbar and is suitable for both propane and butane liquefied petroleum gas.

Note: Regulator valves should always be in the 'OFF' position when towing.

The 30mbar bulkhead mounted regulator fitted to the caravan requires a 'pigtail' connector for use with UK LPG cylinders, see your dealer for details.

To effect a safe connection with a European cylinder, you will need to obtain a 'pigtail' connector appropriate to the cylinders available in the country you are visiting.

DO NOT use the conventional cylinder-mounted 28mbar/37mbar regulators as the gas pressure is not compatible with the appliances installed in your new caravan/motorhome.

Hoses

Inspect flexible hose(s) regularly for deterioration and renew, as necessary, with approved type. In any case not later than the expiration date marked on the hose. LPG hoses should be routinely replaced at intervals not exceeding 5 years or as recommended in manufacturers' instructions. Any hoses that show signs of splitting, wear or damage should be replaced irrespective of age.

If the gas supply hose is to be left disconnected for an extended period ensure the open end is protected against the entry of dirt or insects.

TYPES OF GAS

Butane

Butane is supplied in the U.K. in blue bottles.

Butane is suitable for use at temperatures down to 2°C, but will not work below that temperature.

Propane

Propane is supplied in red bottles which have a left-hand threaded connector.

Propane will work at temperatures as low as -40°C and is therefore suitable for winter caravanning.

Make sure that heating and cooking appliances are turned off, and also the regulator at the gas cylinders before travelling.

Never allow modification of LPG systems and appliances except by qualified persons.



GAS SAFETY ADVICE

Facts about LPG

LPG is not poisonous.

Bi-products are harmless.

There is danger if all air and oxygen were excluded. (Ventilation holes must be kept clear at all times).

LPG has been given a smell by the manufacturers in order to identify leaks.

Awning Spaces LPG Appliance Exhaust

There is no danger of pollution of an enclosed awning space by the LPG exhaust from a refrigerator venting into it.

Space heaters may produce sufficient exhaust to pollute the awning space, if it is totally enclosed, from a general comfort, smell and hygiene point of view. In the extreme case there could be a build up of carbon dioxide to a dangerous level.

Caravan owners are advised to allow some fresh air circulation in the awning space when such appliances are in use.

PRECAUTIONS

- a) Never look for a leak with a match. Always use a soap solution or its equivalent when testing connections. Do not operate any electrical apparatus whatsoever, especially light switches. If the leak is not obvious, the caravan should be evacuated and qualified personnel consulted.
- b) Avoid naked lights when connecting or changing a cylinder.
- c) Check the flexible hose frequently.
- d) The gas is heavier than air and therefore sinks to the lowest point.
- e) Keep bottle gas containers outside (and protected against frost). If they must be kept inside make sure they are well away from heat.

Ventilation

Fresh air circulation should be allowed below the caravan when appliances are in use and when flues terminate below the floor to allow free evacuation of the products of combustion. At least three sides of the underfloor space should always be kept open and unobstructed especially by snow. Do not make any additional openings in the floor.

Fixed ventilation openings are sited under gas appliances in various locations in your tourer.

WARNING

Under no circumstances should fixed ventilation openings or gas appliance flues be obstructed in any manner as this could lead to a build up of dangerous carbon monoxide. Gas drop holes under appliances should also be kept clear at all times. Grilles and flues should be kept clean and free from dust.

All ventilation complies with BS EN1645 and vents should not be obstructed in any manner as this could lead to insufficient fresh air. In this case the confined atmosphere becomes depleted of oxygen which leads to the formation of the highly poisonous gas 'carbon monoxide'. Carbon Monoxide is odourless, colourless and tasteless and will rapidly cause unconsciousness and death with little or no warning prior to collapse. **THERE IS NO DANGER WHEN ADEQUATE VENTILATION IS PROVIDED.**



SERVICES

Roof-mounted Flue installations

All flue installations should be inspected once a year throughout their length for corrosion. Flues should be replaced if any sign of perforation is found. Ensure that the replacement is of an approved type.

CONNECTION

Ensure that the gas regulator is correctly connected to the gas cylinder in gas bottle compartment and that the hose is tight. Before turning on the gas supply, ensure that all gas operated equipment in the caravan is turned off.

Safety Hints

It is advisable to TURN OFF THE MAIN VALVE on the gas container when the caravan is left unattended for a period or is on tow, except where continuous operation appliances (such as a refrigerator) are in use. AVOID NAKED LIGHTS when connecting or changing a container. Make sure all appliances are turned off.

Space Heating Appliances

Space heating appliances are to be completely extinguished before the caravan is moved and are not to be used when the caravan is in motion. Portable heaters should not be used.

Manifold Locations

Heater and Water Heater manifold located underneath front O/S bed towards bulkhead.

Cooker and Fridge manifold located within compartment below cooker.

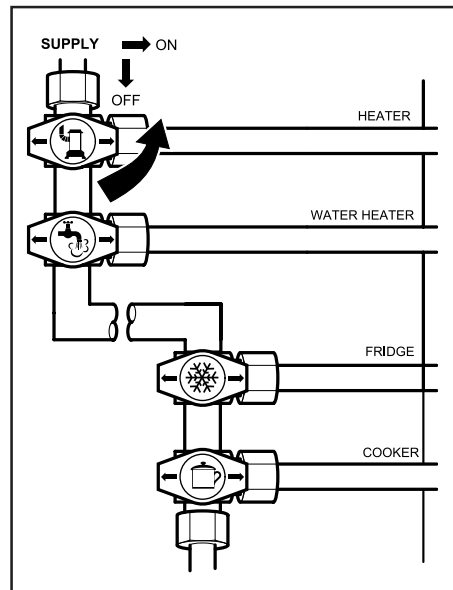



MAINS ELECTRICS

230V Mains Electric Equipment Usage

For your convenience and pleasure this touring caravan is fitted with a 230V mains electrical installation.

Please note: It is possible that all of the 230V mains electrical equipment may not be able to be operated simultaneously. A typical UK caravan park mains hook up point provides a maximum output of 16 amps, although 10 amps is more common and on some continental sites the available output may be as low as 5 amps. If your loading exceeds the site supply it may trip the park's circuit breaker. Please check the available mains output with your site operator.

The following items need to be added together if used simultaneously.

230V mains equipment typical consumption figures:

Fridge	0.5 amps
Charger	1.0 amps
Water heater	3.6 amps
Blown air heaters	4.8 amps
Colour TV	2.5 amps
Microwave	3.5 amps
Air conditioning	4.0 amps
Truma Ultraheat (max)	8.3 amps
Kettle	3.2 amps
Alde central heating	10.0 amps

The mains wiring in Lunar caravans manufactured in the UK complies with the IEE Wiring Regulations, 17th edition, and is safe for the use in the UK. In the UK the on/off switching is always positioned in the live wire. Therefore when the switch is off the current is dead.

Correct polarity of the site supply should always be obtained by the use of a non-reversible plug and socket for connecting the cable to the caravan inlet.

Reverse polarity on overseas use: A plug in polarity tester is used to determine if the polarity is reversed, if so and the site connector is of the two pin type with the two metal strips for the earth, then the plug may be unplugged and inserted the other way round which will then reverse the polarity.

Unfortunately the overseas practice is not always to discriminate between live and neutral wires and the plugs are not necessarily non-reversible. They can be inserted the wrong way round. Consequently when switches are turned off the circuits are not dead. People may touch connections thinking that they are safe and they may still receive a shock.

A residual current device is already fitted to your Lunar Caravan. If a fault occurs and anyone makes indirect contact with a live lead the breaker should trip before a

dangerous voltage is apparent.

It is essential that you understand the workings of each electrical circuit. Check supply cable terminals are firm and secure.

Check supply cables for wear and damage. Do not attempt modifications to the caravan electrical installation to accommodate a double supply.

INSTRUCTIONS FOR ELECTRICITY SUPPLY

On Arrival at Caravan Site

- Before connecting the caravan installation to the mains supply, check that:
 - the main supply is suitable for your installation and appliances, i.e. 230 volts AC, frequency 50 Hertz.
 - your installation will be properly earthed. Never accept a supply from a socket outlet or plug having only two pins, or from a lighting outlet.
 - any residual current device (earth leakage circuit breaker) in the mains supply to the caravan has been tested within the last month. In case of doubt, consult the site owner or his agent.



SERVICES

Note: Always disconnect the electrical connector between the towing vehicle and the caravan before connecting an LV (low voltage) supply to the caravan and before charging the caravan battery by any other means.

2. Ensure that your caravan mains isolating switch (MCB) is in the off position. The RCD is the main isolating switch. The MCB's are the breakers for the individual circuits.
3. Remove any cover from the electricity inlet provided on the caravan, and insert the connector of the supply flexible cable.
4. Remove any cover from the socket outlet provided at the site supply point, and connect the plug (at the other end of the supply flexible cable) to this. Switch on the main switch at the site supply point.

IN CASE OF DIFFICULTY CONSULT AN APPROVED ELECTRICAL INSTALLATION CONTRACTOR (WHO MAY BE THE LOCAL ELECTRICITY COMPANY). IT IS DANGEROUS TO ATTEMPT MODIFICATIONS AND ADDITIONS YOURSELF, LAMPHOLDER PLUGS (BAYONET-CAP ADAPTORS) SHOULD NOT IN ANY CIRCUMSTANCES BE USED.

On Leaving the Caravan Site

5. Reverse the procedure described in Paragraphs 3 and 4 above.

IT IS IMPORTANT THAT THE MAIN SWITCH AT THE SITE SUPPLY POINT SHOULD BE SWITCHED OFF, THE SUPPLY FLEXIBLE CABLE DISCONNECTED, AND ANY COVER REPLACED ON THE SOCKET OUTLET AT THE SITE SUPPLY POINT. IT IS DANGEROUS TO LEAVE THE SUPPLY SOCKET OR SUPPLY FLEXIBLE CABLE LIVE.

Periodically

6. Preferably not less than once a year, the caravan electrical installation should be inspected and tested and a report on its condition obtained as prescribed in the Regulations for Electrical Installations published by the Institute of Electrical Engineers.

Never allow modification of electrical systems or appliances except by qualified persons.

Outlet sockets located within the tourer should only be used with a dedicated appliance and not an independent unit.

No appliance shall be used outside when connected to an internal socket.

YOUR CARAVAN IS NOW SUPPLIED WITH 25 METRES OF MAINS CABLE TO COMPLY WITH BS EN1645.

FLEXIBLE WIRING

LIVE	BROWN
NEUTRAL	BLUE
EARTH	GREEN & YELLOW

FIXED WIRING

LIVE	BROWN
NEUTRAL	BLUE
EARTH	GREEN & YELLOW

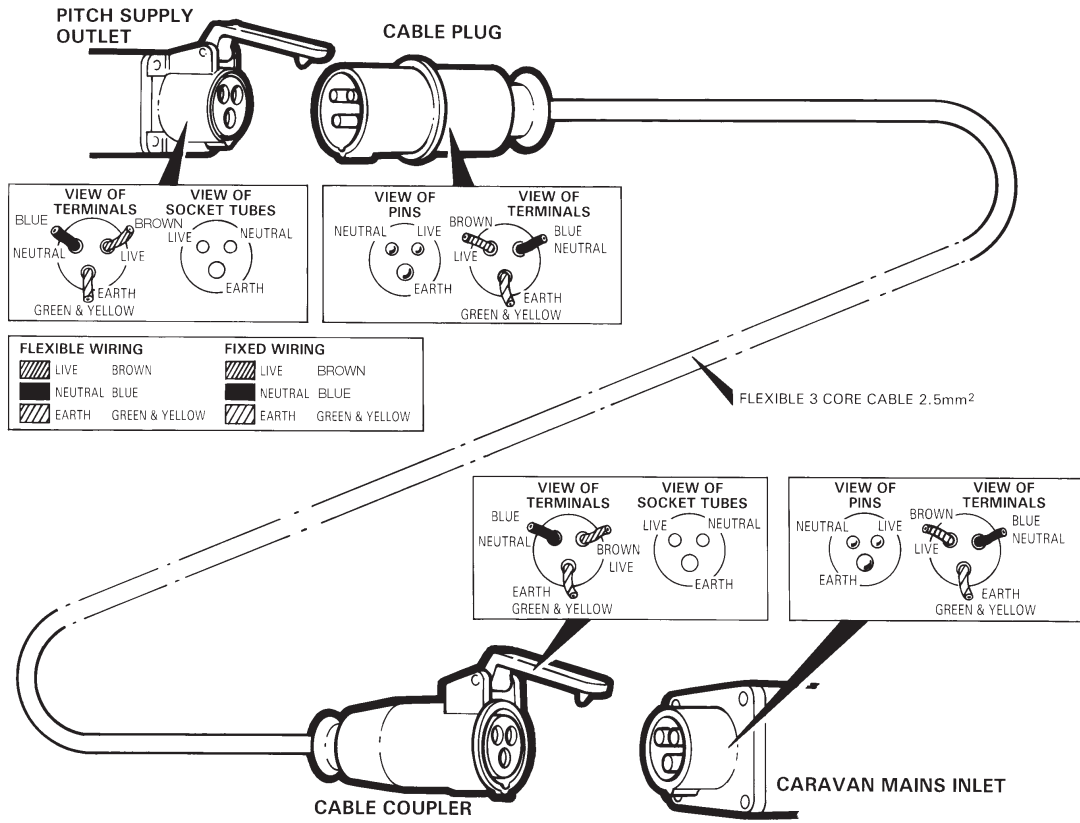

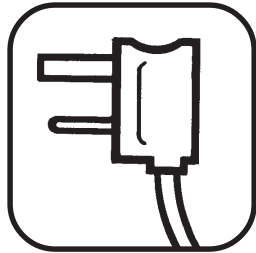

ELECTRICS

Mains Power Units	48
Distribution Panel	49
Control Panel	50
Battery	52
Use of Generators	52



ELECTRICS

POWER DISTRIBUTION UNIT PDU

The PDU contains both the 230v ac equipment and the Power Supply to give 12 volts dc. This is capable of running the 12 volts system on its own or in conjunction with a leisure battery. It is however advisable to run with a battery in circuit.

Contained within the PDU are all the input and output circuit fuses. These are clearly identified and have the size of fuse clearly marked, this rating should not be exceeded.

230volts ac

Containing the Earth leakage protection RCD (Residual Current Device) and the Overprotection current device MCB's (Miniature Circuit Breakers).

12volt dc

Fully automatic power supply capable of running the 12 volt system up to 20 amps at 13.8 volts.

If a fault condition such as a short circuit or overload occurs, the power supply will automatically switch off until the fault is removed. This system is also capable of charging a totally flat lead acid, gel or AGM battery, however depending on its state this may take up to 48 hours. It is also recommended that you only use the power

supply in the PDU to charge your leisure battery.

Control system

Within the PDU relays control the system automatically when it chooses Car or Van Supply. When the Caravan is plugged into the Car then it will automatically switch to use the Car. However care should be taken when using power from the car battery, as this could drain the voltage of the car battery rendering insufficient voltage to start the car.

Continued use of a car battery to supply power to the caravan will in time cause damage to a car battery, and it is recommended to fit a leisure battery to the caravan.

When the Car ignition is switched on and the engine is started the interior supply to the Caravan 12 volt system will switch off (except alarm if fitted), and the supply to the fridge is connected. When the car engine is switched off the 12 volt power to the caravan is restored, however the 12-volt power to the fridge will be disconnected.

Ensure that the steps on page 43 "*Instructions for electricity supply*" are followed.

OPERATION

Disconnect the electrical connector between the towing vehicle and the caravan before connecting an LV (low voltage) supply to the caravan and before charging the caravan battery by any other means.

Connect the 230 volt mains lead to the mains inlet fitted within the battery box, and then connect to the supply on the caravan site. Switch on the RCD and MCB's, at this point it is important to check the operation of the RCD and check the polarity of the site connection using a polarity tester. If the polarity is incorrect the site operators should be notified and rectified by a qualified electrician.

Specification

Power supply
230 volt ac (+/- 10%)
Output voltage 13.8 volts dc
Output current 20 Amps
Dimensions
H 235mm W 375mm D 80mm

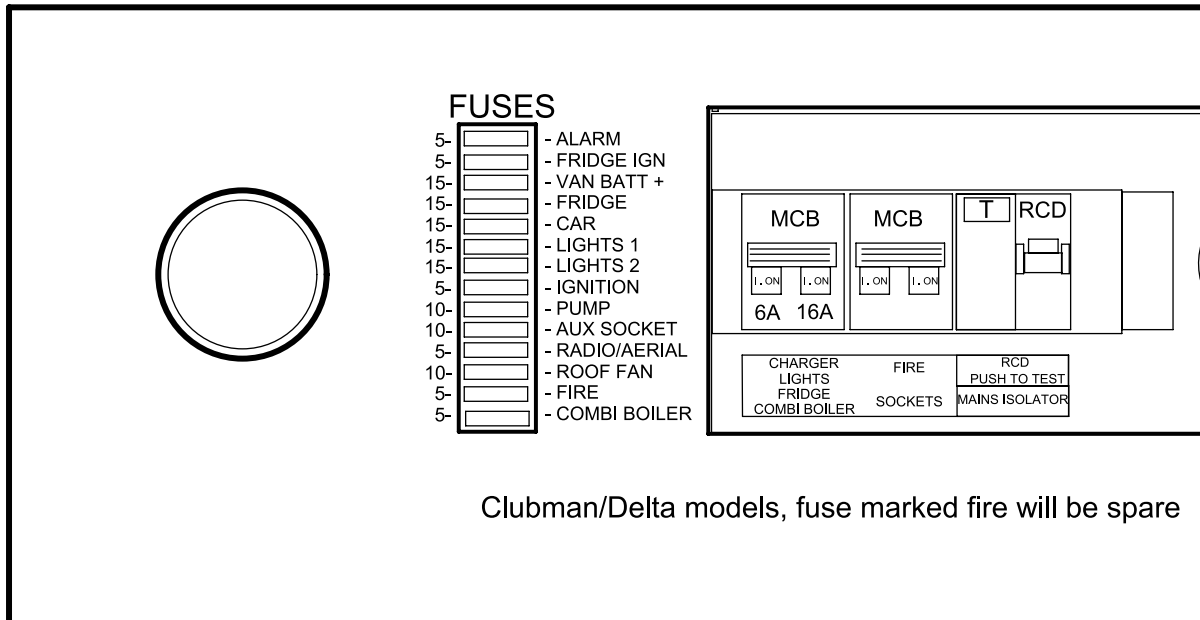

Power Distribution Unit



ELECTRICS

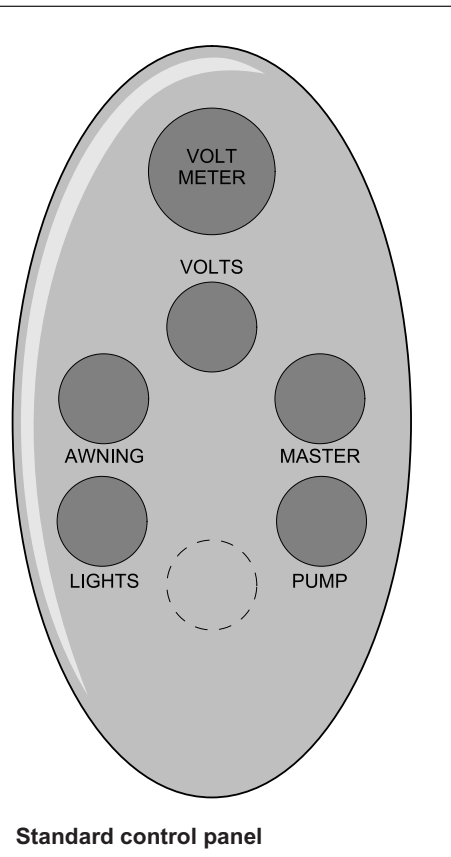

Standard Control Panel

All models feature a control panel governing the master switch, external water pump, awning light, internal lights and volt meter readings.

Master switch. Controls all the 12 volt supply to the caravan which is provided by the car/leisure battery or power supply, with the exception of the alarm, tracker, awning light and fridge ignition depending on fridge model.

Pump switch. Activates external pump. The light will illuminate when power is being provided to the pump.

Volt switch. When pressed illuminates the Volt Meter dial and shows the voltage being supplied by the power supply, leisure battery and car supply when connected to the car.

Awning switch. Activates/deactivates the external awning light situated above the entrance door of the caravan. On models fitted with the Lunar Protector Caravan Alarm, if this switch is left in the on position then the awning light can be operated via the alarm remote handset.

Light switch. Activates/deactivates the interior central light closest to the entrance door, providing the power switch mounted on the central light is switched ON.

Delta Control Panel

This has features governing the master switch, awning light, internal light, volts and onboard water level external water pump and internal water pump.

Master switch. Controls all the 12 volt supply to the caravan which is provided by the car/leisure battery or power supply with the exception of the alarm, tracker and fridge ignition depending on fridge model.

Pump switch. Activates the external pump. An LED will be illuminated when power is being provided by the pump.

Int/Ext switch. When in the internal position the internal pump fitted in the underfloor water tank is operational. If the water level falls to a pre-determined level it will automatically switch to the external pump until the underfloor water tank water level rises.

When in the external position the external pump will be operational and will automatically fill the underfloor water tank. LEDs are situated adjacent to the switch indicating which pump is activated.

Volt switch. When pressed illuminates the volt meter and shows the voltage being supplied by the power supply, leisure battery, or car supply when connected to the car. It



also operates a series of coloured LED lights situated to the left of the volt meter, the more LEDs lit the fuller the underfloor water tank.

Awning switch. Activates/deactivates the external awning light situated above the entrance door of the caravan. This switch if left in the ON position will enable the awning light to be operated via the alarm remote handset.

Light switch. Activates/deactivates the interior central light closest to the entrance door, providing the power switch mounted on the central light is switched ON.

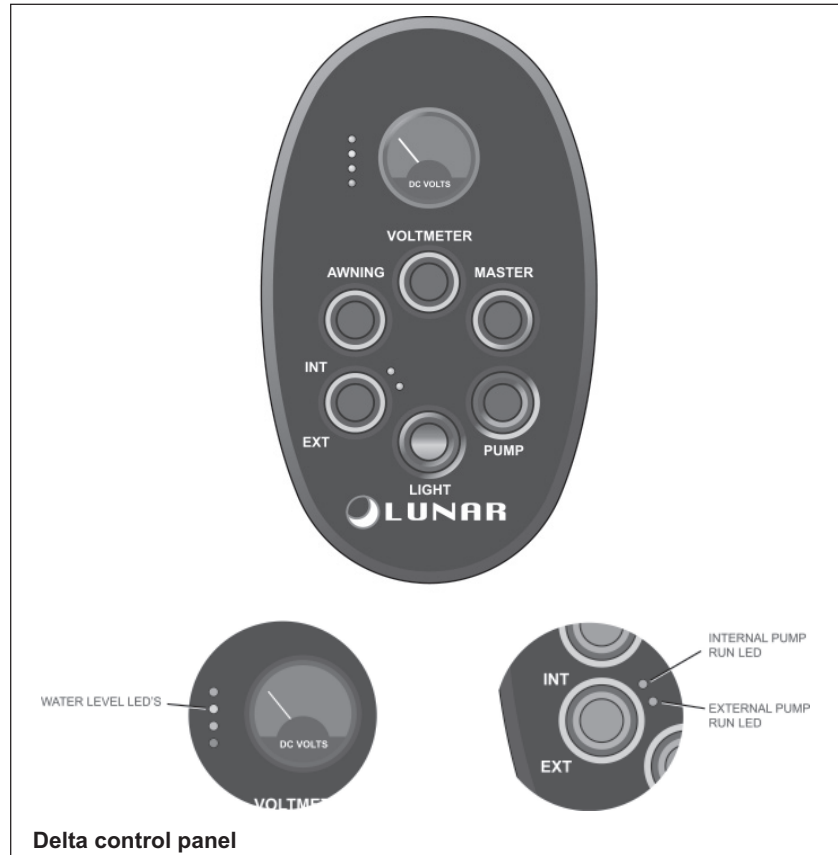



ELECTRICS

GENERAL INFORMATION

BATTERY

For optimum performance and safety it is essential that only a good quality CARAVAN battery is used. A normal car battery is NOT suitable.

WARNING

One of the most common causes of caravan battery failure is for the battery to be discharged below the recommended level of approximately 10.5 Volts and therefore causing one or more cells to fail.

Provided the appropriate relay is fitted to your car and the connection is made via the 13 pin plug and socket, a small trickle charge is achieved from car battery to the leisure battery when towing.

The auxiliary battery compartment is located on the offside of the caravan, with easy to fit and clearly identified positive and negative connectors.

It is recommended that a good quality leisure battery is always in circuit when the system is in use.

A heavy duty 12v battery should be purchased to provide power for lights and other electrical appliances. A proprietary

brand leisure battery with a 60, 90 or 110 amp capacity is recommended. (It must have tube venting capability for internal battery boxes).

It should be remembered that batteries suitable for the electrical demands of a caravan differ in design from those for use with a car, and whilst the system may operate with a car battery it is strongly recommended that only a caravan/leisure type battery, maintained in good condition is used. The battery should be kept topped up at all times.

The battery should be positioned in the designated vented compartment and properly secured. When connecting the battery, ensure that the correct polarity is observed (black is negative and red is positive) and that the terminals are securely fastened. (Crocodile clips are not recommended.)

Under normal circumstances it should not be necessary to remove the battery other than for routine inspection of terminals and "topping up".

The AC output of generators is often derived from an AC alternator, rectified to DC then inverted back to AC. In essence this means the output sinewave may not be very smooth and may not run sophisticated electronics

efficiently. Some of the new wave of gensets are more sophisticated in their production of a sinewave output and are more suited to run electronic equipment.

If in doubt consult your genset dealer or manufacturer for advice.

WARNING

Explosive gases may be present at the battery. Take care to prevent flames and sparks in the vicinity.

WARNING

Switch off all appliances and lamps before disconnecting the battery.

GENERATOR GUIDELINES

Lack of regular servicing can be the cause of most generator problems. Gensets under 2kW are mainly dependent on engine speed for output frequency and voltage, poor or no servicing may cause the engine speed governor to run the genset engine too fast. Therefore frequency and output voltage can rise above the specification of the machine data plate, i.e. 240v at 50Hz, This may cause damage to electrical/electronic equipment (such as battery chargers).

A generator should always be run for a few minutes prior to connection with the caravan



or motorhome electrics, to allow it to warm up and the output to settle to a steady level.

SUPPORT SERVICE

Contact your local dealer.



FITTED EQUIPMENT

Truma Ultrastore Water Heater	56
Refrigerators	60
Thetford N97	60
Thetford N112	60
Thetford N175	60
Oven, Hob & Grill	65
Trumatic S3002 Space Heater	70
Isolator Switches	72
Truma Ultraheat	72
Alde Heating	74
Thetford C-420 Toilet	76
Thetford C-250 CWE Toilet	79
Awning Points	85
Rooflight	87
TV Antenna	88
Wall Lights	89
Flyscreens/Blinds	90
Condensation	91
Door Flyscreen	91
Body & Window Care	91
Badges	92
Bunk Beds	94



TRUMA WATER HEATER

Note: Most proprietary items within the caravan will have their own instruction book, the information within the Lunar Handbook is an extract of the most relevant aspects.

IMPORTANT

In the interest of safety, replacement parts for an appliance shall conform to the appliance manufacturer's specifications and should be fitted by him or an authorised agent.

To maximise the use and life of all fitted equipment in your caravan it is essential that any accompanying manufacturers' literature is read fully. All recommended maintenance and preparation procedures should be followed. The information provided in this handbook is only intended as a guide. If in any doubt consult your Lunar appointed dealer, particularly before attempting to install EXTRA EQUIPMENT.

TRUMA ULTRASTORE WATER HEATER

This water heater features a dual source system of water heating powered by Liquid Petroleum Gas or 230V mains electricity. For a faster heating up period the appliance can be simultaneously operated with gas and electricity. The holding tank has a capacity of 10 litres.

WARNING

Always fit the cowl cap when the water heater is not being operated. If there is any risk of frost and preferably each time you leave the site, the water heater should be drained leaving all taps open. Frost damage is not covered by the warranty.

The system may be fitted to a mains water supply with special adaptors which include a pressure reducer which does not allow pressure to exceed 2.8 bar.

During the initial operation of a brand new appliance some fumes are normal. These should soon disperse if the caravan is well ventilated.

Filling the Truma Ultrastore

1. Check the safety/drain valve in the cold water intake is closed. The lever should be in the horizontal position (e) Fig. C.

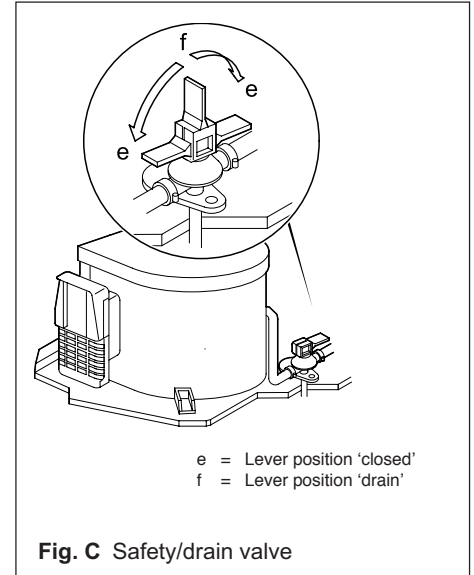

Fig. C Safety/drain valve

2. Set the hot tap in either the washroom or kitchen in the open position.
3. Switch on the power for the water pump.
4. Leave the tap open to let air escape while the water heater is filling. The heater is full when water flows freely from the tap.
5. It may be necessary to adjust the pressure switch on the water system.



N.B. If only the cold water system is being used the heater tank will still be filled with water and to avoid frost damage it should always be drained as described below.

Draining the water heater

1. Disconnect the water pump and switch off power supply where appropriate.
2. Open all hot and cold water taps.
3. Open safety/drain valve and leave in vertical position (f).
4. The water heater will now drain directly to the outside. If towing, it is useful to leave the drain valve open as movement of the caravan will help to ensure that the system is completely drained.
5. Ensure that if a water filter is fitted that this is also drained as well as any water left in the submersible pump.

WARNING

Water may be hot enough to scald.

GAS OPERATING INSTRUCTIONS

Control Panel (Gas Operation)

WARNING

Never operate the water heater without water in it. Always remove the external cowl prior to using the water heater.

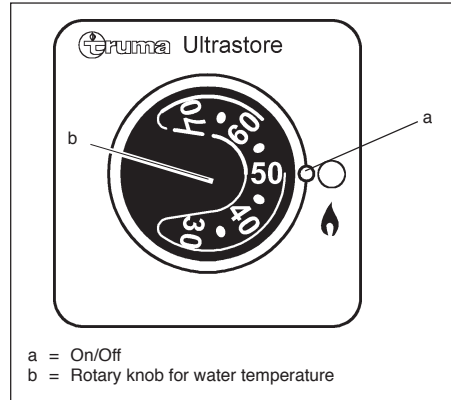

Switching on

1. Remove the external cowl cover by applying pressure with both thumbs to the illustration on the cover whilst pulling the cowl away with the forefingers.
2. Ensure the supply is turned on at the gas cylinder.

3. Select the required water temperature with the inner rotary control (b).
4. Switch on the water heater by turning the outer rotary control (a) to the flame symbol. A green indicator light will come on.

Switching off

Switch the heater off by turning the outer rotary control (a) to 0. If there is a risk of frost, drain the heater.

If the heater is not to be used for a long period the cowl cover should be fitted to ensure that the functioning of the appliance is not impaired by water, dirt or insects. Failure to do this could invalidate the warranty. Turn off the gas supply at the cylinder.

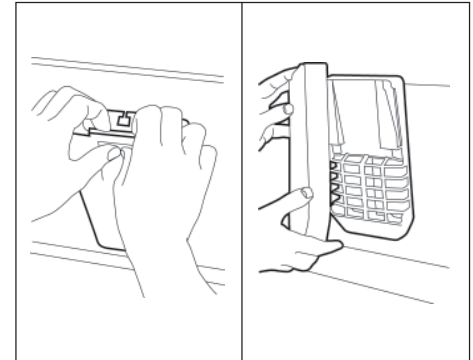



TRUMA WATER HEATER

ELECTRICAL OPERATING INSTRUCTIONS

WARNING

Never operate the water heater without water in it.

Ensure that the water heater is full then press the isolation switch to on.

N.B. The water temperature is not adjustable using the mains heating element. The temperature is set at 70°C. For a faster heating up period the appliance can be simultaneously operated with gas and electrical power.

MAINTENANCE

The water heater should be serviced annually during the routine caravan service.

Repairs

Repairs should only be carried out by qualified personnel as the warranty will be void if unqualified persons attempt repairs. Only original Truma parts should be used.

De-scaling

Introduce wine vinegar into the water system and allow time for it to react with the scale then flush out thoroughly with fresh water.

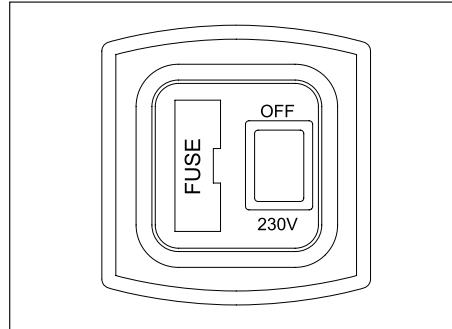

Hygiene

The water tank in the Truma Ultrastore is made of high quality stainless steel, however, in order to avoid colonisation of micro-organisms the tank should be heated up to 70°C (with electrical heater) at regular intervals. Water from the hot tap should not be used for drinking.

Fuses

The water heater fuse is situated on the electronic control unit on the heater. Further protection is provided by a 5 amp fuse fitted in the fuse spur for the isolation of the water heater. This fuse spur is located at the outside bed box.

IMPORTANT Only replace the miniature fuse on the p.c.b. with a fuse of the same type: 1,25 AT EN 60127-2-3 (slow action).

Safety

There is no danger of exhaust gas pollution in awning spaces from water heaters which vent into them but it is advised that fresh air circulation should be provided and any window immediately above the flue outlet should be kept closed.

WARNING

Water heaters (as with other appliances) should be turned off and gas cylinder valves closed whilst the caravan is in motion.

Sterilising the system

At the start of the season or if the caravan has not been used for some time sterilise the water system thoroughly by preparing about 10 litres of water, containing a sterilising agent made specially for the purpose. This should be available from your Lunar distributor. When an on-board tank is fitted ensure that sufficient mixture is prepared to fill the whole tank.

DO NOT use domestic bleach, camden tablets or sodium metabisulphide.

Pump about half of the solution through the system, opening all taps in turn and leave for not longer than 30 minutes. Pump the remainder through. Drain the water heater and water tank (if fitted) then pump at least 18 litres of fresh water through the system



again opening all taps in turn, then drain again.

Similar attention should be paid to the hygiene of the external water container and submersible pump and hose used to draw off water.

DO NOT use water which has stood in a water container for any length of time and do not use garden hoses for filling tanks.

Water filter (where fitted)

Replace the in-line filter cartridge with a new one after sterilising the water system. On no account should the old cartridge be used again as the sterilising agent will have saturated the filter bed.

After fitting the new filter flush the system for around 30 seconds to remove any loose particles of carbon. It is recommended that a new filter is fitted at the start of each season after sterilising the system and again after approximately 30 days usage as the filter becomes less effective after this period.



REFRIGERATOR

THETFORD REFRIGERATOR MODELS N97, N112 and N175

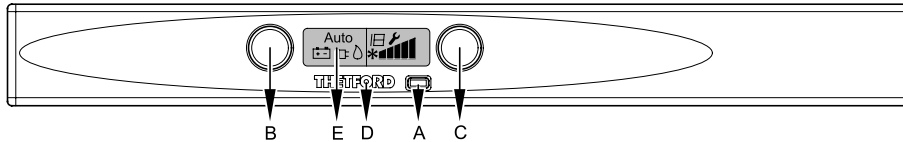

A = Main switch (on/off)

B = Mode selection switch

C = Cooling level selection switch

D = Function LED

E = LCD display



Switching on the refrigerator

- Clean the inside of the refrigerator before you switch it on.
- Let the refrigerator cool for at least eight hours before you place food in it for the first time.
- The freezer compartment should be cold one hour after switching on the refrigerator.

SMART ENERGY SELECTION (SES)

- When you start up the refrigerator (equipped with Smart Energy Selection (SES)) you should usually select the AUTO mode. The SES system will then automatically select the best of the three available energy sources.

The system will apply the following priority:

- mains voltage (230V) 
- direct current (12V) 
- liquid gas 

If an energy source becomes available that has a higher priority than the source the refrigerator is currently using (e.g. if your vehicle engine is started), the system will stop using the current energy source and switch to the energy source with the higher priority.

If a fault occurs in one or more of the possible energy sources, the system will not generate an error message while an alternative energy source is still available.

The SES system switches over automatically.

Note: If none of the energy sources are available, the blue LED flashes every second and an error code is shown in the display.

Automatic models additionally allow you to select the desired energy source manually.

Operation of refrigerator

Important: The memory of the SES system saves every change made to the setting. Consequently, the SES system will start up on each subsequent occasion in the last-selected setting.

- Open the valve of the gas bottle.
- Open the taps of the gas supply.
- Press main switch (A). The function LED will turn blue and all symbols on the LCD display will light up.
- Use the mode selection switch to select the "Auto" function or one of the power supplies that you want. The LCD display will show the option you have selected.
- Set the desired refrigerating cooling level by means of the cooling level selection switch (C). The LCD display will show the cooling level setting you have selected.



- A. Use the main switch to switch the refrigerator on and off. The function LED will turn blue. The display LCD shows the most recent settings. After 10 seconds the LCD display's backlight will go out. The function LED remains blue.
- B. Press the mode selector switch and the LCD display backlight will show the setting for 10 seconds. Pressing the mode selector switch successive times take you through the menu in the following sequence: AUTO, manual DC (12V), manual gas, manual mains voltage (230V) and back to AUTO. Select either the AUTO option or one of the other power supplies that you want to use. The LCD display shows the option you have selected. If you select the AUTO option, the system will choose the most suitable power supply and the AUTO symbol and the symbol of the power supply chosen by the system will both be shown on the LCD display. Ten seconds after release of the mode selector switch, the system will switch off the LCD backlight.
- C. Use the cooling level selector switch to control the temperature of the refrigerator. When you press the cooling level selector switch, the LCD backlight will light up and show the currently set temperature. Every time you press the cooling level selector switch again, you

set the refrigerator one position cooler. On reaching the coldest temperature, the system will start again at the warmest temperature setting. Ten seconds after release of the cooling level selector switch, the system will switch off the LCD backlight.

POWERING WITH ELECTRICITY

Powering with electricity can be selected both by the Auto mode (only automatic fridges) and manually.

Auto mode - mains voltage

This energy source will be selected if the mains voltage is greater than 200V. This power supply requires a continuous current of 12V to operate the electronic control system.

Auto mode - direct current (12V)

The SES system will select 12V powering only if a mains voltage (230V) is unavailable, the vehicle engine is running and a voltage higher than 11V is available. If a fault occurs during electrical powering (230V or 12V), an error message will not be shown on the display as long as another energy source is available. The system will automatically switch to the available energy source that has the highest priority.

Selecting electrical power manually

Mains voltage (230V):

NOTE: The LED warns you whenever insufficient voltage is available or if a fault occurs. If this happens, the LED will start flashing once per second and an error code is shown in the LCD display.

When sufficient current is available again, or the fault has been resolved, the LED will emit a steady blue light again.

Direct current (12V):

NOTE: The LED warns you whenever your vehicle's engine is not running, or if a fault occurs, or if insufficient voltage is available. If this happens, the LED will start flashing once per second and an error code is shown in the LCD display.

Once the engine is running, or the fault has been resolved, or sufficient voltage is available again, the LED will again emit a steady blue light.

NB: If the refrigerator has been manually set to operate at 12V, it will not automatically switch to another energy source when your vehicle's engine is not running. In this case, the refrigerator will stop cooling.



REFRIGERATOR

POWERING WITH GAS

Powering with gas can be selected both by the Auto mode (only automatic fridges) and manually.

Auto mode

The system will select gas operation if:

- mains voltage (230V) is unavailable.
- the vehicle's engine is not running.

Once mains voltage (230V) is available again or the vehicle's engine is running, the system will switch to the available energy source that has the highest priority if the fridge is in auto mode.

If the refrigerator switches from 12V DC to gas operation when it is in auto mode, the system will wait for about 15 minutes before igniting the gas. During this time, however, the gas indicator lamp will come on. The delay is built in to avoid it switching to gas operation whenever you stop to refuel your vehicle. You can cancel the delay by immediately switching the refrigerator off and then on again.

If the system selects gas operation, the ignition will be activated automatically. The gas will flow to the burner and be lit by the electric ignition. If the flame goes out, the gas will immediately be lit again.

Selecting gas operation manually

NOTE: If the flame cannot be lit within 30 seconds, the gas supply will stop and gas mode will be switched off. The LED will start flashing every second and an error code is shown in the LCD display.

The gas mode can be reset only if the refrigerator is switched off. If you switch the refrigerator on again and the gas mode is still not working, the LED of the manual gas mode will flash to indicate that gas is unavailable and an error code is shown in the LCD display.

WARNING

It is prohibited to use gas to power the refrigerator while driving. If a road accident results in a fire, there is a danger of explosion. It is prohibited to use gas to power the refrigerator in the vicinity of petrol stations. If it takes longer than 15 minutes to refuel your vehicle, switch the refrigerator off using the main switch (A).

Switching off the refrigerator

- Push the main switch (A).
- The blue LED will go out.
- The refrigerator is now completely switched off.
- Use the special storage latch on the door locking mechanism to fixate the open door. This prevents unpleasant odours and mould in the refrigerator.



TROUBLESHOOTING

Before calling the authorised Service Department please check whether:

- The instructions in the section “Operation of refrigerator” have been followed.
- The refrigerator is not tilted excessively.
- It is possible to operate the refrigerator with an available power source.

Failure: The refrigerator does not work on gas.

<i>Possible cause</i>	<i>Action you can take</i>
a) Gas bottle empty.	a) Change gas bottle.
b) Valve of the gas bottle or one of the shut-off valves is closed.	b) Open the valve of the gas bottle or shut-off valve(s).
c) Air in the gas pipe?	c) Switch device off and on again 3-4 times to remove air from the gas pipe.

Failure: The refrigerator does not work on 12V.

<i>Possible cause</i>	<i>Action you can take</i>
a) 12V fuse is defective.	a) Fit new fuse.
b) On-board battery discharged.	b) Check battery, charge it.

Failure: The refrigerator does not cool sufficiently.

<i>Possible cause</i>	<i>Action you can take</i>
a) Inadequate ventilation to the unit.	a) Check that the ventilation grilles are not covered.
b) The thermostat setting is too low.	b) Turn the thermostat to a higher setting.
c) There is too much ice on the condenser.	c) Check that the refrigerator door seals when shut.
d) Too much warm food put inside.	d) Let food cool down first.
e) Gas burner is dirty.	e) Have the gas burner cleaned.
f) Door does not shut properly.	f) Check the door closing mechanism.



REFRIGERATOR

WINTER OPERATION

If you use the refrigerator when the outdoor temperature is below 8 deg C, install the Thetford vent winter/storage cover on the ventilation grills. The cover protects your refrigerator from excessively cold air. The winter cover is a refrigerator accessory obtainable from your caravan dealer.

NOTE: Do not use the winter/storage cover in temperatures greater than 8 deg C as this can damage the cooling unit at the rear of the fridge.

Remove the covers and re-fit when placing the vehicle back into storage.

MAINTENANCE

- Works on gas components and electrical installation may only be carried out by authorised personnel. We recommend you contact the Customer Service Department of Thetford
- EN 1949 stipulates that the appliance's gas equipment and its associated fume system must be inspected after installation and a certificate issued.
Afterwards a qualified technician must inspect according to EN 1949 every two years and a certificate issued.
It is the user's responsibility to arrange for inspections after purchase.
- It is recommended that the gas burner be

inspected and cleaned as necessary at least once a year.

We recommend maintenance following an extended shutdown of the vehicle.

FURTHER DETAILS

Consult the accompanying literature to obtain the full benefit of your Thetford Refrigerator.

In the event of failure, contact Thetford Customer Service Department. Details of which can be found in your Yellow Pages Directory.

Service & Spare Parts

In the event that a refrigerator develops a fault and requires the attention of a Thetford Service Representative, consult the Europe wide list of service centres supplied with the refrigerator.



ASPIRE DUEL FUEL OVEN

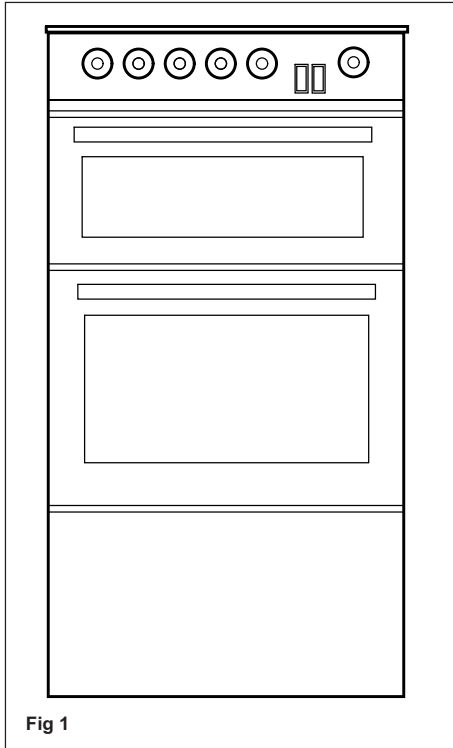

Fig 1

OPERATION

Hotplate burners

Ensure the gas cylinder is turned on.

In the event of a gas smell turn off at the cylinder and contact supplier.

Flame supervision: each burner is controlled individually and is monitored by a thermocouple probe. In the event of the burner flames being accidentally extinguished, turn off the burner control and do not attempt to re-ignite the burner for at least one minute.

CAUTIONS:

- (1) When cooking, young children should be kept away.
- (2) Glass lids may shatter when heated. Turn off all burners and grill before shutting lid.
- (3) Spillage on the surface of the lid should be removed before opening the lid.
- (4) Do not use foil on the hob, as it creates a fire hazard.
- (5) The glass lid has a tendency to snap shut towards the end of lowering. This is caused by the travel lock action of the hinges as it is activated. Make sure all fingers are removed from appliance when closing the lid.

Operation

To light the grill, push in the control knob and turn to full rate (see Fig 2. Hold a lighted

match or taper to the burner and push the control knob in and hold. It is necessary to hold the knob depressed after the burner has ignited for approximately 10-15 seconds, to allow the thermocouple probe to reach temperature, before releasing the knob. Should the flame go out when the knob is released, the procedure should be repeated holding the knob depressed for slightly longer.

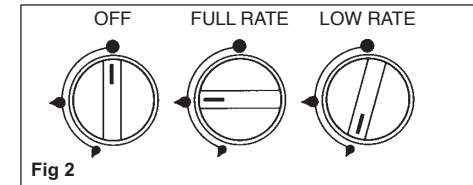

Fig 2

For models fitted with spark ignition the procedure is similar except that the burner can be ignited by depressing the ignition button, which is located on the fascia. If the burner has not lit within 15 seconds the control knob should be released and the burner left for at least one minute before a further attempt to ignite the burner.

For simmering, turn the knob further anti-clockwise to the low rate position.

To turn off: Turn the control knob until the line on the control knob is aligned with the dot on the control panel. Always make sure the control knob is in the off position when you have finished using the hotplate burners.



OVEN, HOB & GRILL

IMPORTANT:

- Each burner will support pans from 10 to 22 cm diameter, care should be taken not to overload the appliance as performance may be reduced.
- The following pan sizes are the maximum we recommend: electric hotplate 18cm dia, auxiliary burner 20cm dia, semi-rapid burner 2x20cm dia or 1x22cm dia with 1x18cm dia.
- When using small pans the flames should not spread beyond the base of the pan as this will reduce the efficiency of the burner.
- Avoid old or misshapen pans as these may cause instability.
- The lid must be opened fully prior to using the hotplate burners.

Using the Electric Hotplate

Ensure the electricity is switched on. The hotplate control is numbered from 1 to 6. To turn it on, rotate the knob either clockwise or anti-clockwise to the required position. Position 1 is the coolest setting. To turn off, rotate the knob until the line or pointer on the knob lines up with the zero on the control panel.

The hotplate is a sealed construction and transfers heat through conduction. For maximum efficiency a correctly sized pan with a flat heavy gauge base should be used. Pan size should be the same or slightly larger (up to 2.5cm oversize).

CAUTIONS:

- (1) Ensure the glass lid is open before turning on the hotplate burners.

WARNINGS

- Children should be supervised to ensure they do not play with the appliance.
- Glass lids may shatter when heated. Turn off the hotplate and allow it to cool before closing the glass lid.
- Remove all spillage from the surface of the glass lid before opening.
- The glass lid has a tendency to snap shut towards the end of lowering. This is caused by the travel lock action of the hinges as it is activated. Make sure all fingers are removed from appliance when closing the lid.

The grill

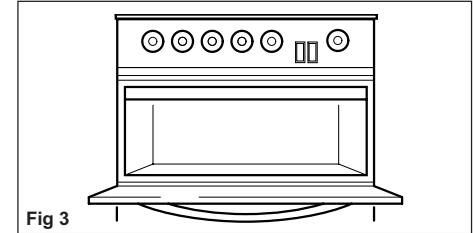

Fig 3

1. Ensure gas cylinder/supply is connected and turned on. In the event of a gas smell turn off at gas cylinder/mains and contact supplier.
2. To light: Open door, push in the control knob and turn to full rate (see Fig 2). Hold a lighted match or taper to the burner and push the control knob in and hold. The burner should ignite and the control knob should be held in for 10-15 seconds before release. If the burner goes out, repeat procedure holding control knob for slightly longer.
3. For models fitted with spark ignition the procedure is similar except that the burner can be ignited by depressing the ignition button, which is located on the fascia. Ignition must be carried out with the door open, and if the burner has not lit within 15 seconds the control knob should be released and the grill left for at least one minute before a further attempt to ignite the burner.



4. Note: The grill must only be used with the door open.
5. On first use of the grill, it should be heated for about 20 minutes to eliminate any residual factory lubricants that might impart unpleasant smells to the food being cooked. A non-toxic smoke may occur when using for the first time so open any windows and turn on mechanical ventilators to help remove the smoke.
6. Although the grill does heat up quickly, a few minutes preheat is recommended.
7. Flame Failure Device (FFD): The grill burner is fitted with a flame sensing probe, which will automatically cut off the gas supply in the event of the flame going out. In the event of the burner flames being accidentally extinguished, turn off the burner control and do not attempt to re-ignite the burner for at least one minute.
8. It is normal for the flames on this burner to develop yellow tips as it heats up, particularly on butane.
9. A reversible grill pan trivet enables the correct grilling height to be achieved.

Fast toasting	trivet in high position
Grilling sausages	trivet in high position
Grilling steak/bacon	trivet in high position
Grilling chops, etc.	trivet in low position
Slow grilling	trivet removed

10. To turn off, turn the control knob until the line on the control knob is aligned with the dot on the control panel. Always make sure the control knob is in the off position when you have finished grilling.

WARNINGS:

- When the grill is being used, accessible parts may be hot, young children must be kept away.
- The grill area can get hot when the oven is in use, even if the grill is switched off.
- Care should be taken when removing parts from the grill, i.e. use of oven gloves, and by making use of the removal grill pan handle.

Notes:

- The grill pan supplied is multi functional, for use in grill or oven.
- The handle design allows removal or insertion whilst the pan is in use.
- Always remove the handle when the pan is in use,
- The grill **MUST** only be used with the door open.

The oven

CAUTIONS:

- When you are cooking, keep children away from the oven.
- Do not use foil on the oven shelves, as this creates a fire hazard and can hinder circulation of heat.

1. Ensure gas cylinder/supply is connected and turned on. In the event of a gas smell turn off at gas cylinder/mains and contact supplier.
2. To light: Open door, push in the control knob and turn to full rate (240°C). Hold a lighted match or taper to the burner and push the control knob in and hold. The burner should ignite and the control knob should be held in for 10-15 seconds before release. If the burner goes out, repeat procedure holding control knob for slightly longer.
3. For models fitted with spark ignition the procedure is similar except that the burner can be ignited by depressing the ignition button, which is located on the fascia. Ignition must be carried out with the door open, and if the burner has not lit within 15 seconds the control knob should be released and the oven left off at least one minute before a further attempt to ignite the burner.
4. Place the oven shelf in the required position and close the door. Set control knob to approximately 200°C and heat the oven for about 30 minutes to eliminate any residual factory lubricants that might impart unpleasant smells to the meals being cooked. A non-toxic smoke may occur when using for the first time so open any windows and turn on



OVEN, HOB & GRILL

mechanical ventilators to help remove the smoke.

5. Although the oven does heat up quickly, it is recommended that a 10 minute preheat be allowed. The oven should be up to full temperature in about 15-20 minutes.
6. To turn off: turn the control knob until the line on the control knob is aligned with the dot on the control panel.
7. **Shelf:** The shelf has been designed to allow good circulation at the rear of the oven and are also fitted with a raised bar to prevent trays or dishes making contact with the back of the oven. To remove a shelf, pull forward until it stops, raise at front and remove.

DO'S AND DON'TS

DO read the user instructions carefully before using the appliance for the first time.

DO allow the oven to heat fully in order to expel any smells before introducing food for the first time.

DO clean the appliance regularly.

DO provide additional ventilation, such as opening windows near grill, cooker and oven when cooking.

DO remove any spills as soon as they occur.

DO use oven gloves when removing food shelves and trays from a hot oven.

DO check the controls are in the off position when finished.

DO NOT allow children near the cooker when in use. Turn pan handles away from the front so that they cannot be caught.

DO NOT allow fats or oils to build up in the oven trays or base.

DO NOT use abrasive cleaners or powders that will scratch the surface of the hot plate and oven.

DO NOT under any circumstances use the oven as a space heater.

LEAKS

If a smell of gas becomes apparent, the supply should be turned off at the cylinder immediately.

Extinguish naked lights including cigarettes and pipes. Do not operate electrical

switches. Open all doors and windows to disperse gas escapes.

Butane/Propane gas is heavier than air and escaping gas will collect at a low level. The strong unpleasant smell of gas will enable the general area of the leak to be detected. Check that the gas is not escaping from an unlit appliance.

Never check for leaks with a naked flame; leak investigation should be carried out using a leak detector spray or soapy solution.

MAINTENANCE

This appliance needs little maintenance other than cleaning. All parts should be cleaned using warm soapy water. Do not use abrasive cleaners, steel wool or cleansing powders. When cleaning the burner ring it is essential that the holes do not become blocked. The control knobs are a push fit and can be removed for cleaning. They are interchangeable without affecting the method of operation.

THIS APPLIANCE MUST NOT BE MODIFIED OR ADJUSTED UNLESS AUTHORISED AND CARRIED OUT BY THE MANUFACTURER OR HIS REPRESENTATIVE. NO PARTS OTHER THAN THOSE SUPPLIED BY THE MANUFACTURER SHOULD BE USED ON THIS APPLIANCE.



WARNINGS:

On no account should this appliance be used as a space heater.

All pans should be mounted centrally over the burners, even when cooling, to protect adjacent walls.

Do not lower hob cover until burners and grill have cooled.

Do not store equipment in the pan cupboard so that movement whilst travelling causes them to fall against the glass door causing damage.

This appliance must not be modified or adjusted unless authorised and carried out by the manufacturer or his representative.

No parts other than those supplied by the manufacturer should be used on this appliance.

Never use a portable cooker in your tourer.

When you are cooking it is essential to provide additional ventilation, such as opening windows near grill, cooker and oven.



TRUMATIC S3002

TRUMATIC S 3002 GAS HEATER

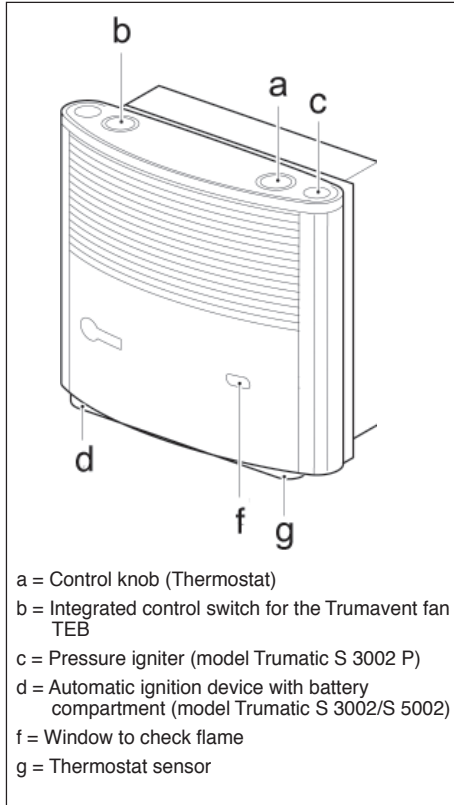

Switching On (Automatic Igniter)

Prior to first ignition, make sure that the batteries have been inserted. Observe correct fit of battery cassette.

1. Turn on gas cylinder and ensure valve in the gas supply line is open.
2. Turn control knob (a) to thermostat setting 1–10 and press it down as far as the stop. Ignition takes place automatically (ignition sparking audible) until the flame ignites.
3. Keep the control knob pressed down for a further 10 seconds to allow the safety pilot to operate.
4. Observe through the inspection window for a further 10 seconds so as to check that the flame has not been extinguished due to air in the line (caused by a change of gas cylinder).
5. In the event of a fault, always wait 2 minutes before attempting to re-ignite.
6. If the flame goes out again, re-ignition is carried out immediately during the closing time of the safety pilot (approx. 30 seconds).

If there is no flame, the automatic ignitor continues to operate until the control knob is switched to '0'.

7. If ignition sparking is not audible or only at intervals of more than a second, the batteries must be changed.

8. To ensure even and rapid warm air distribution as well as lower surface temperatures on the heating unit, we recommend that you operate the heater with a Trumavent warm air system.

Switching On (Piezo Ignitor)

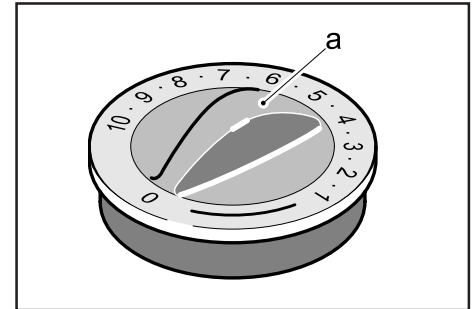

1. Turn on gas cylinder and open quick-acting valve in the gas supply line.
2. Turn control knob (a) to thermostat setting 1-10 and press it down as far as the stop. At the same time keep operating the piezo ignitor rapidly until the flame ignites.
3. Keep the control knob pressed down for a further 10 seconds to allow the safety pilot to operate.



Thermostat

Set the required room temperature at the control knob (numbers 1–10). For an average room temperature of approximately 22°C we recommend setting 3–5 without Trumavent fan and 4–8 with Trumavent fan.

Switching Off

Set control knob to '0'. If turning off for a longer period of time, close the valve in the gas supply and turn off gas cylinder.

Removing the heater cover

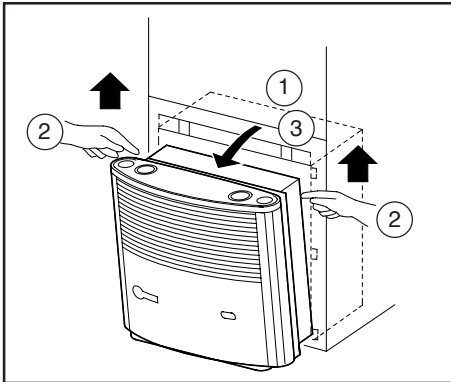

1. Pull the cover forward at the top.
2. Lift up the retaining springs and;
3. Pull the cover forwards.

Changing batteries on automatic ignitor

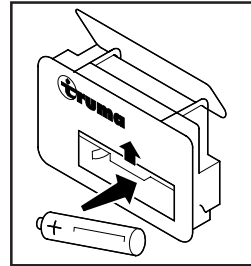

If no ignition sparking can be heard, or only at intervals of more than one second (or if the monitor lamp "e", a special accessory, is not flashing), the battery needs to be replaced.

Replace the battery only if the heater is switched off. Insert a new battery before the start of the heating season.

Remove the heater cover (see Point 1), push the battery compartment cover up and change the battery. Ensure that the polarity is correct. Close the battery compartment again.

Only use temperature resistant (+70°C), leak-proof Mignon round cells (VARTA Industrial Alkaline, No. 4006-1.5V-AA-MIGNON-LR6, AM3-MN1500-Made in Germany, 0% mercury, 0% cadmium), other batteries could lead to malfunction.

Cleaning (only when the unit is switched off)

It is recommended that at least once a year, before the start of the heating season, the

dust should be removed which may have collected on the heat exchanger, the baseplate, and the fan wheel of the Trumavent hot air system. Clean the fan wheel carefully with a dusting brush or small paintbrush.

Important Notes

1. If the gas supply line is filled with air, it may take up to a minute before the gas becomes available for combustion. During this time hold the control knob pressed down and continuously operate the piezo ignitor until the flame ignites.
2. You will have to find out the exact thermostat setting yourself, depending on how much heat you need and the way your vehicle is designed.

The thermostat probe is underneath the heater. Please note that the thermostat will be adversely affected by cold draughts from refrigerator vents, gaps below doors, etc. or by a deep-piled carpet. Always make sure to avoid problems of this kind, otherwise satisfactory temperature control cannot be guaranteed.



TRUMA ULTRAHEAT

ISOLATOR SWITCHES

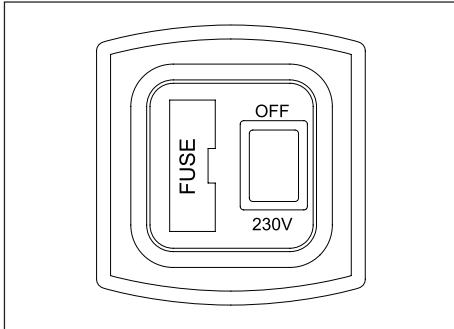

The isolator switch is a fuse spur fitted with a 10 amp fuse. This fuse spur is located adjacent to the water heater fuse spur at the offside bed box.

TRUMA ULTRAHEAT – Additional electric heating for Trumatic S3002 Heaters

Switching On

Warning: Before switching on, ensure that the fuse protection for the power supply of the camp site is sufficient for the selected power setting (b).

Important: The mains electric hook-up lead must be fully unwound.

1. Turn the outer rotary control (a) to the required power setting.

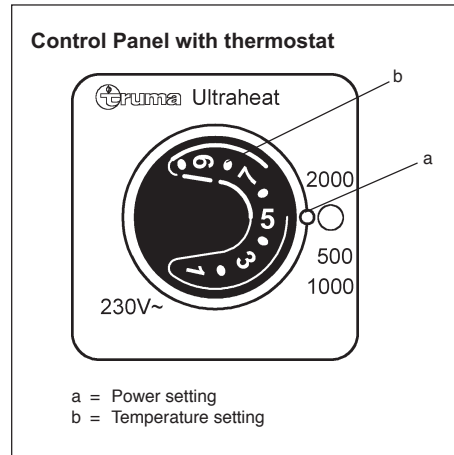

2. Set the inner rotary control to the desired room temperature.

The electric heater can also be operated without the Trumavent fans.

If the heater is operated simultaneously with electricity and gas, the electrical unit will switch itself off before overheating occurs as a result of the stronger gas burner.

Switching Off

Turn the outer rotary control (a) to 0.

Important Notes

1. Repairs may only be carried out by an expert.
2. The heater's hot air outlet should under no circumstances be blocked. Never hang clothes or similar in front of or on top of the heater to dry. This could cause serious damage to the heater as a result of overheating. Do not place inflammable materials near the heater. Please observe these instructions for your own safety.
3. When operating a brand new heater for the first time (or when it has been idle for a lengthy period) you may temporarily notice a slight smoke and smell. We advise running the heater at full power and thoroughly ventilating the room.



4. Any modifications to the appliance or the use of spare parts important for the operation which are not original Truma parts will result in the guarantee becoming invalid.
5. Do not obstruct the front or rear of the control panel with thermostat. Always ensure there is airflow around it or the thermostat will not operate.

Warning: Heater surfaces become hot in use and the guard provided does not give full protection to the young or elderly.

Warning: Additional independent gas appliances must not be used inside the caravan.



ALDE HEATING

ALDE HEATING – Quick Start Guide

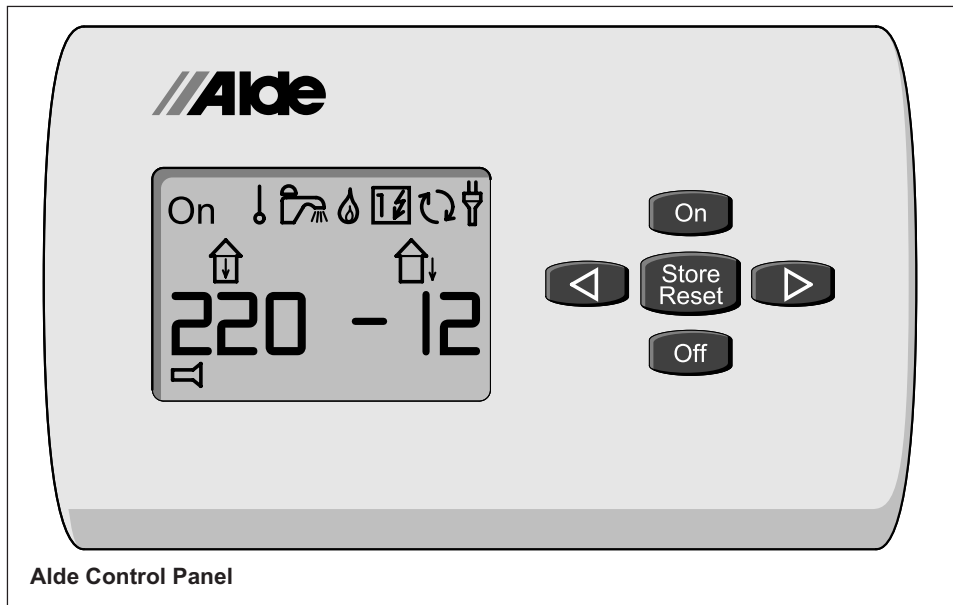

PRE-START CHECKS

1. Ensure the system is filled with Glycol before starting the boiler, check the expansion tank level. The fluid should be 10mm above the minimum mark when cold.
2. Ensure adequate LPG Propane, 230V and 12V supplies are connected and turned on. The control panel should be active and display the 230V connection symbol.

3. Turn the boiler 'ON' using the control panel, then scroll across and raise the desired room temperature to +30°C. The circulation pump symbol should appear. Visually check in the expansion tank that the pump is operating.
4. Scroll across and turn on the 2kW electric heater using the panel. Wait for 10 minutes and check that the upper flow pipe on the boiler is getting hot. The bottom return pipe may also be warm.
5. Scroll back and turn on the gas burner using the control panel. You might not be able to hear it start, so visually check the flue outside to confirm the boiler is operating. Wait for 10 minutes and check the lower return pipe on the boiler. It should now be hot and the boiler fully operational.

6. **Isolator Switch:**
The isolator switch is a fuse spur fitted with a 10 amp fuse. This fuse spur is located at the outside bed box.

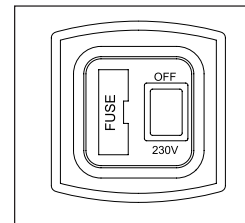











ALDE QUICK START OPERATING INSTRUCTIONS

Use the Left < and Right > arrow keys to move across the symbols.

Highlight the required symbol so that it flashes. You can then adjust that function.

Use the +/ON and -/OFF keys to adjust settings and turn functions ON and OFF.

	<p>With 'On' displayed the boiler is in standby mode and ready to be given commands.</p>
	<p>With 'Off' displayed the boiler is shutdown.</p>
	<p>Select your desired room temperature to call for heating.</p>
	<p>30 min hot water booster, with this function 'On' the circulation pump for the heating is turned off.</p>
	<p>Select 'On' to operate the boiler LPG.</p>
	<p>Select 1 or 2 kW to operate the boiler on 230V electric.</p>
	<p>Indicates that the circulation pump is operating for central heating.</p>
	<p>Indicates that 230V is supplied to the boiler.</p>



THETFORD TOILETS

THETFORD CASSETTE TOILET C-402

PREPARING FOR USE

Open the access door on the outside of your caravan or camper.

Turn the water filling funnel outwards, remove the cap and add the stated amount of Thetford toilet fluid for the water tank. This ensures a better and cleaner flush and keeps the water in the flush tank fresh. After this, fill the water tank with clean water.

Screw the cap back onto the water filling funnel and turn it back inwards towards the side of the flush water tank.

NOTE: 150 ml water remains in the water filling funnel when the water tank is empty.

1. Remove the waste tank by pulling the safety catch upwards.
2. Pull the waste tank outward to the stop. Tip it slightly and take the tank fully out.
3. Place the tank upright and turn the emptying spout upwards.
4. Remove the cap, with the measuring cup inside, from the emptying spout and pour the stated quantity of toilet fluid into the waste tank. This avoids unpleasant smells in the waste tank and keeps the inside of the waste tank clean. Next add approximately 2 litres of water - enough

to ensure that the bottom of the waste tank is covered. Screw the cap back onto the emptying spout. Turn the emptying spout back to its original position.

WARNING: Never add toilet fluid via the valve blade or via the toilet bowl.

5. Slide the waste tank back into its original position via the access door.

NOTE: Never use force if you cannot get the tank back into place easily. This may cause serious damage.

6. Make sure that the waste tank is secured with the safety catch. Shut the access door and lock it.
7. Run water into the bowl by pressing the flush knob briefly or open the valve blade by turning the handle anti-clockwise. Your Thetford toilet is now ready for use.
8. After use, open the valve blade (if still closed) by turning the handle anti-clockwise. Flush the toilet by pressing the flush knob for several seconds. Close the valve blade after use.

NOTE: Do not leave water in the bowl if the toilet is not being used. This does not help to reduce unpleasant smells and only leads to flooding.

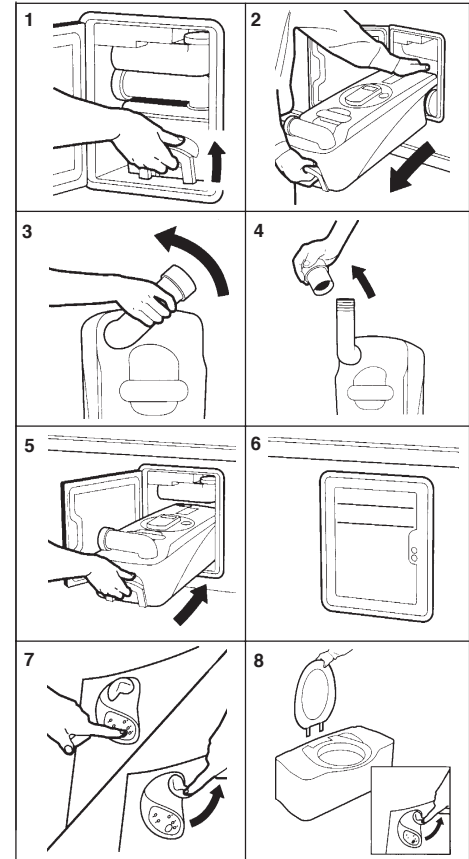

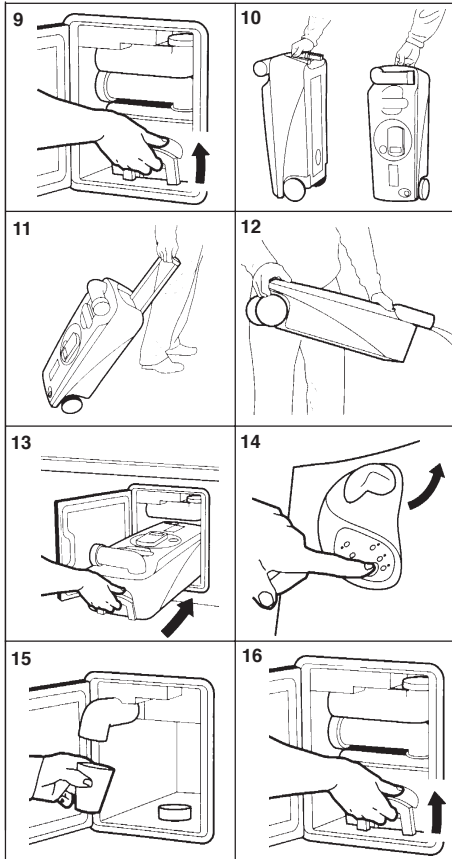

Comment: To avoid blockages we advise the use of Thetford's fast dissolving toilet paper, Aqua Soft.

EMPTYING

The waste tank has a capacity of 19 litres and must be emptied at the latest when the red light in the level display lights up. The indicator lamp will light up when the waste tank can still take about 2 litres, which is about three uses. It is advisable to empty the waste tank earlier.

NOTE: Do not allow the waste tank to become too full.

9. Make sure that the valve blade is closed. Open the access door located outside the vehicle. Pull the safety catch upwards and remove the waste tank.
10. Stand the waste tank upright (Pull-out handle at the top, wheels at the bottom). Press the handle down and move it away from the waste tank until it snaps out of its locked position.
11. Pull the handle up and wheel the waste tank to an authorised waste dump.
12. Push the handle back. Turn the emptying spout upwards and remove the cap from the spout. Hold the waste tank by the upper handle with one hand, while placing your other hand by the rear handle so that during emptying you can

operate the vent plunger with your thumb. To empty the tank without splashing, depress the vent plunger while emptying the tank. After emptying, flush the tank thoroughly with water. Also clean the valve blade with water.

NOTE: The vent plunger should only be pressed once the emptying spout is pointing downwards!

13. If required make the toilet ready for use once again. Slide the waste tank into the toilet and close the access door.

STORAGE

It is important that you follow the instructions below if you do not expect to use the Thetford toilet for a long period.

14. Open the valve blade by turning the handle on the toilet anti-clockwise. Press the blue knob until the water stops flowing into the bowl. Close the valve blade.
15. Open the access door on the outside of your caravan or camper and turn the water filling funnel outwards. Remove the cap and empty the water filling funnel by turning it a quarter turn anti-clockwise.
16. Remove the waste tank and empty this at an authorised waste dump. Follow the instructions for cleaning and maintenance.



THETFORD TOILETS

17. Replace the waste tank and open the valve blade by moving the handle on the toilet to the left.

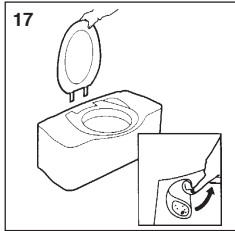

CLEANING AND MAINTENANCE

The toilet should be cleaned and maintained regularly, depending on the amount of use. To clean Thetford toilets, we advise using water and Thetford Plastic Cleaner.

NOTE: Never use household cleaners (bleach, solvents or other powerful cleaning agents). These may cause permanent damage to the seals and other toilet components.

Toilet:

- * Squirt Thetford Plastic Cleaner in the toilet.
- * Flush the bowl with water and wipe down the rest of the toilet with a damp cloth.

TIP: For a really shining toilet, dry it with a soft dry cloth after cleaning.

- * Clean seat and lid. The seat and lid can easily be removed. Lift the lid and seat together and pull upwards. After cleaning,

replace the seat and lid by positioning the round pins above the holes and then pushing the lid and seat downwards.

Waste Tank:

We advise a thorough cleaning of the waste tank once each season.

- * Remove the mechanism from the waste tank by turning it anti-clockwise, as shown on the waste tank. Rinse the complete mechanism under a tap.
- * Remove the cover plate from the automatic pressure release vent by prising it up using a screwdriver. Use one hand to push the automatic pressure release vent open, while holding the float of the automatic pressure release vent on the inside of the tank with the other hand. Push the float upwards, turn the float a half turn and remove it from below. Remove the rubber seal that is under the float. Rinse the float and rubber seal under a tap. Replace the rubber seal and the float for the automatic pressure release vent in the same way.

The rubber seal in the toilet (the valve blade seal, the mechanism seal, the automatic pressure release vent seal and the cap seal) should be regularly treated with Thetford High Grade Seal Lubricant. This will ensure that the seals remain supple and in good condition. If the toilet is not to be used for any length of time, it is important to treat the

seals with Thetford High Grade Seal Lubricant after cleaning.

NOTE: Never use Vaseline or any vegetable oil except olive oil. These may cause leakage.

N.B.: The valve blade seal is a part of the toilet that is subject to wear. Depending on the extent and manner of service, after a certain period the seal will become less effective and must be replaced.



THETFORD C-250 CWE CASSETTE TOILET

INTRODUCTION

The Thetford Cassette Toilet is a high quality product. The toilet forms an integral part of your caravan or camper bathroom, thanks to its functional design which combines modern styling and ease of use. The C-250 Cassette Toilet is manufactured from high quality synthetic materials which makes it a durable, user and maintenance friendly toilet.

The toilet is made up of two parts: a permanently fixed part and a Waste Holding Tank that is accessible from the outside. The removable Waste Holding Tank is located under the toilet bowl and can be removed via a door on the outside of the caravan or camper. The Thetford Cassette Toilet is the solution to the sanitary problem in your caravan or camper!

The operating instructions cover Thetford Cassette Toilet models C-250S, C-250CS (models connected to the vehicle's central water tank) and C-250CWE (model with its own flush-water tank). There are differences in the use of these models. Please ensure that you follow the instructions that apply to your toilet model.

Standard C-250

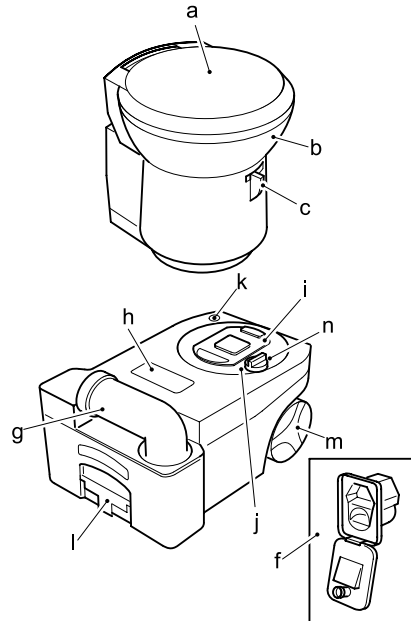

Optional features C-250

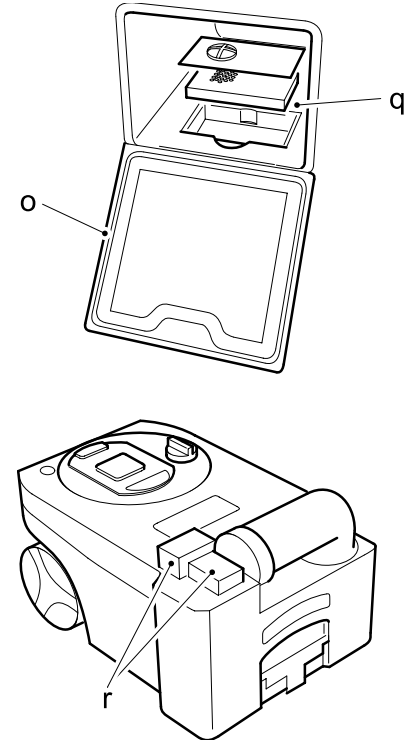



THETFORD TOILETS

Control panel (with optional features)

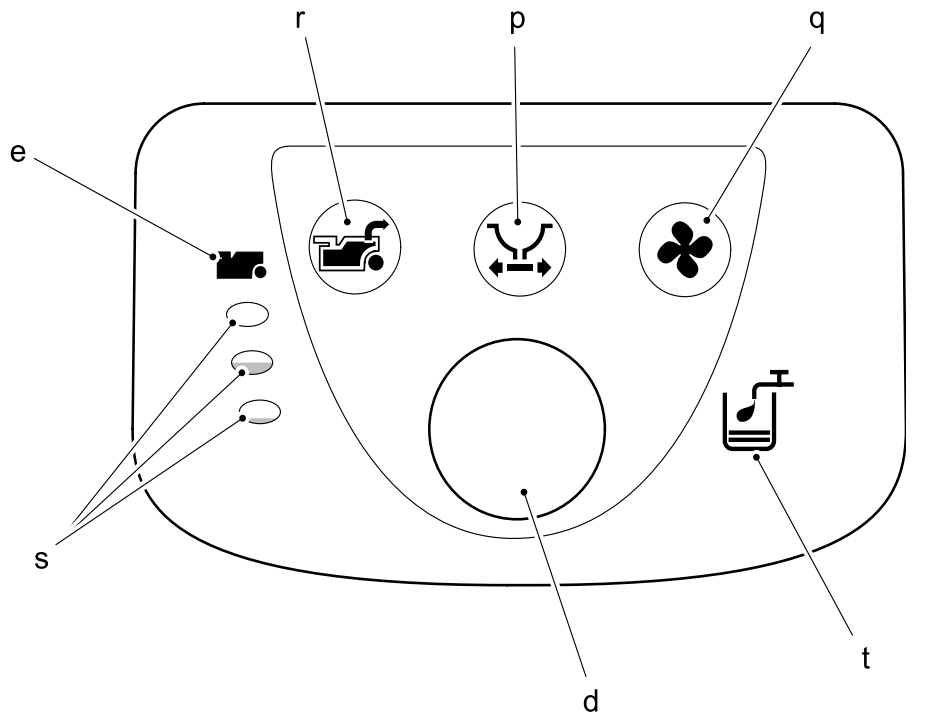

PARTS

- a) Removable Seat and Lid
- b) Swivelling Toilet Bowl
- c) Blade Handle
- d) Flush Button
- e) Waste Holding Tank Level Indicator
- f) Water Filling Door (only if toilet has own flush-water tank)
- g) Rotating Emptying Spout
- h) Automatic Pressure Release Vent
- i) Sliding Cover
- j) Removable Mechanism
- k) Vent Plunger
- l) Pull-out Handle
- m) Wheels
- n) Blade Opener

- o) Access Door to Waste Holding Tank

Optional Features

- p) Electric Blade
- q) Automatic Ventilator
- r) Waste Pump-Out System
- s) Waste Holding Tank Multi-Level Indicator
- t) Flush-Water Tank Level Indicator (only if toilet has its own flush-water tank)

Note: Optional features can be bought from Thetford dealerships.



Preparing for use (standard)

1. Open the access door on the outside of your caravan or camper.
2. Remove the Waste Holding Tank by pulling the safety catch (which holds the tank in place) upwards.
3. Pull the Waste Holding Tank outward to the stop. Tip it slightly and take the tank fully out.
4. Place the tank upright and turn the rotating emptying spout upwards. The emptying spout ensures that the tank can be easily and hygienically emptied.
5. Remove the cap, with the measuring cup inside, from the emptying spout and pour the correct dosage of Thetford toilet fluid (see product label) into the holding tank. This avoids unpleasant smells and keeps the inside of the tank clean. Next add approximately 2 litres of water - enough to ensure that the bottom of the Waste Holding Tank is covered. For more information on Thetford toilet fluids, see last page of this manual. Screw the cap back onto the emptying spout and turn back to its original position.

Note: The Emptying Spout Measuring Cap is supplied in the same packaging as this manual.

WARNING: Never add toilet fluid directly via the blade or the toilet bowl as this

could damage the lip seal of the Waste Holding Tank. Always pour the fluids via the emptying spout.

6. Slide the Waste Holding Tank back into its original position via the access door. Make sure that it is secured with the safety catch. Close the access door and lock it. Your Thetford toilet is now ready to use.

WARNING: Never use force if you cannot get the tank back into place easily. This may cause serious damage. If blockage occurs, always check if the blade handle is in the correct (closed) position.

7. For toilets with own Flush-Water Tank: Open the water filling door and fill the flush-water tank with the correct dosage of Aqua Rinse. This Thetford toilet fluid keeps the flush water fresh and improves the flushing. Next, fill up the flush-water tank with clean water (approximately 8 litres) using a ferry can or hose. Your toilet is now ready to use.

Preparing for use with Optional Features

8. Automatic Ventilator: Open the access door on the outside of your caravan and remove the Waste Holding Tank (as described above).
9. Remove the filter housing cover and if no filter is present, place a new filter into the filter housing. Peel off the sticker lids on the filter. Place back the cover of the filter housing.

Using the toilet (standard)

10. Turn the bowl to the desired position with the lid closed and using both hands.
11. To activate the control panel, press the flush-button once. The control panel display will stay activated for approximately 5 minutes. Run some water into the bowl by pressing the flush button again briefly.
12. The toilet may be used with the blade open or closed. To open the blade, slide the blade handle under the toilet bowl sideways. After use, open the blade (if still closed) and flush the toilet by pressing the flush button for several seconds (if necessary re-activate the control panel). Close the blade after use.

WARNING: If your toilet has its own flush-water tank, please make sure that



THETFORD TOILETS

you do not travel with a flush-water tank that is too full. Do not travel with water in the toilet bowl. Failure to adhere to this notice may result in water damage to your caravan or motor home.

Using the toilet with Optional Features

13. **Electric Blade:** Push the electric blade button on the control display to electrically open or close the blade. In the case of failure, you can manually open or close the blade by sliding the small handle under the toilet bowl sideways.
14. **Automatic Ventilator:** The ventilator automatically starts when the control panel is activated (by pressing the flush button) and will automatically shut off after approximately 5 minutes. The Automatic Ventilator Indicator will flash until automatic shut-off occurs. If you want to stop the ventilator, press the Automatic Ventilator button. If you want to re-start the ventilator, press the button again (the LED will start flashing again).
15. **Flush Water Tank Level Indicator** (only for toilets with own flush-water tank): When the Flush Water Tank Level Indicator lights up, refill the flush-water tank, as only about 1.5 litres of water is left in the tank, which is sufficient for approximately 2 flushes.

Emptying

The Waste Holding Tank has a capacity of 18 litres and requires emptying when the red light (LED) on the toilet control display lights up, when the Waste Holding Tank only has capacity for approximately 2 more litres, which is no more than two to three further uses.

Make sure that the blade is closed. Open the access door located outside the vehicle, pull the safety catch upwards and remove the Waste Holding Tank.

16. Place the Waste Holding Tank in an upright position (Pull-Out Handle at the top, Wheels at the bottom). Slide the handle sideways - to the front of the tank - until it snaps out of its locked position.
17. Pull the handle up and wheel the Waste Holding Tank to an authorized waste disposal point.
18. Push the handle back into its locked position. Turn the emptying spout upwards and remove the cap from the spout. Hold the Waste Holding Tank in such a way that during emptying you can operate the vent plunger with your thumb. To empty the tank without splashing, depress the vent plunger while emptying the tank. After emptying, rinse the tank and blade thoroughly with water.

WARNING: Do not seriously shake the tank or use high pressure water cleaners. This may cause damage to the tank's interior.

Note: The vent plunger should only be depressed once the emptying spout is pointing downwards. Prepare the toilet for re-use if required. Slide the Waste Holding Tank into the toilet and close the access door.

Emptying with Optional Features

19. **Waste Holding Tank Multi-Level Indicator:**
The lower lamp indicates that the Waste Holding Tank is almost empty; the middle lamp indicates that it is more than half full; when the upper lamp lights up, the tank needs emptying as it can only take 2 - 3 further uses.
Note: The Waste Holding Tank Level Indicator will flash when the holding tank is not present. In this case the toilet will not flush.
20. **Waste Pump-Out System:** When activating the control panel this feature automatically lights up. When the Waste Holding Tank Level Indicator illuminates, press the Waste Pump-Out button to pump out the waste from the holding tank into the vehicle's waste tank. The button will flash while the waste is being



pumped and will stop automatically (after approximately 5 minutes) when all waste has been transferred. If the vehicle's waste tank is full, the Waste Pump-Out light will flash rapidly and no pump-out will be possible until the central tank is emptied. (Check the level of the vehicle's waste tank on the vehicle's central console). After the Waste Holding Tank has been emptied, there will be approximately 1.5 litres of waste left in the tank. This is normal. Add 2 litres of water and a correct dosage of Thetford toilet fluids to the Waste Holding Tank.

CAUTION: It is vital that the correct amount of toilet fluid is added to ensure the proper breakdown of the waste in the holding tank. Only use the system when the tank is full. Using the system too often on an empty tank can cause damage to the pump, which could cause the system to fail.

CLEANING AND MAINTENANCE

The toilet should be cleaned and maintained regularly, depending on the amount of use. To clean Thetford toilets, we advise using water and Thetford Bathroom Cleaner.

Note: Never use bleach, vinegar or other powerful household cleaners that contain these substances. These may cause permanent damage to the seals and other toilet components.

Toilet Bowl

- Squirt Thetford Bathroom Cleaner into the toilet bowl.
- Flush the toilet bowl with water and wipe down the rest of the toilet with a damp cloth.
- Clean seat and lid The seat and lid can easily be removed: Lift the seat and lid assembly and pull the round pins (inside the assembly) outwards from the pin holes. After cleaning, replace the seat and lid by positioning the round pins in front of the pin holes and push the lid and seat downwards.
- To keep your flush water fresh and to prevent deposits from forming in your toilet bowl, add a correct dosage of Aqua Rinse in your flush water tank, if present, on your toilet.

Tip! For a really shining toilet, dry with a soft dry cloth after cleaning.

Waste Holding Tank

To keep your Waste Holding Tank fresh and clean, Thetford has developed a number of different toilet fluids. Thetford toilet fluids suppress smells, reduce formation of gas, promote breakdown of toilet waste and increase the life span of a mobile toilet. We advise a thorough cleaning of the Waste Holding Tank once each season. Next to using Thetford's Cassette Tank Cleaner, the powerful cleaning agent for the periodical cleaning of the Waste Holding Tank of your toilet, we suggest the following: -

- Remove the removable mechanism from the Waste Holding Tank by turning it anti-clockwise and rinse it under a tap.
- Remove the cover plate from the Automatic Pressure Release Vent by prising it up using a small screwdriver. Use one hand to push the Automatic Pressure Release Vent open while holding the float of the Automatic Pressure Release Vent on the inside of the tank with the other hand. Push the float upwards, turn it 180 degrees and remove it from below. Remove the rubber seal underneath the float. Rinse the float and rubber seal under a tap. Replace the rubber seal and float for the Automatic Pressure Release Vent using the same method in reverse.



THETFORD TOILETS

The rubber seals in the toilet (the lip seal, the mechanism seal, the automatic pressure release vent seal and the cap seal) should be regularly cleaned with water and treated with Thetford High Grade Seal Lubricant. This will ensure that the seals remain flexible and in good condition. If the toilet is not to be used for any length of time, it is important to treat the seals with Thetford High Grade Seal Lubricant after cleaning.

Note: Never use Vaseline or any vegetable oil except olive oil. These may cause leakage or malfunction. The lip seal is a part of the toilet that is subject to wear. Depending upon the extent and manner of use, the seals will become less effective and will need replacing periodically.

Cleaning and Maintenance for Optional Features

- **Automatic Ventilation:** The filter of the Automatic Ventilation needs to be renewed periodically. After approximately 4 full weeks of use, the filter loses its absorption power.
- **Pump-Out Waste System:** To ensure optimal functionality of the Pump-Out Waste System, periodical maintenance of the tube and pump is recommended. After emptying the Waste Holding Tank completely, fill it with clean water and empty it again. This will clean the pump

and the hose. Do this once every 3 weeks when on holiday. This should ensure proper operation of the system.

Winter operation

You can use your Thetford Cassette Toilet as normal in cold weather as long as the toilet is situated in a heated location. If there is a risk of freezing we advise that the toilet is drained by following the instructions under 'Storage'. For environmental reasons the use of antifreeze, such as that used in car radiators, is not recommended.

Storage

It is important that you follow the instructions below if you do not expect to use your Thetford toilet for a long (winter) period.

- Activate the Control Panel by pressing the flush button. Open the blade and press the flush button until water stops flowing into the bowl. Close the blade. Open the access door on the outside of your caravan or camper and empty the Waste Holding Tank at an authorized waste dump. Follow the instructions for cleaning and maintenance. To allow the Waste Holding Tank to dry, do not place the cap back on the emptying spout of the tank.
21. If the toilet has its own flush-water tank, place a sufficiently large bowl under the

drain tube to catch the remaining water from the flush-water tank and remove the drain plug. When no more water exits, put the drain plug on the drain tube, put it back in its original position and close the access door. If the toilet is connected to the vehicle's water tank, please follow your vehicle's instructions for draining the central water system. If your toilet is optionally featured with a Waste Pump-Out System, take out the Waste Holding Tank and completely clean it (see Cleaning and Maintenance). After cleaning, fill it with water, put it back and empty it via the waste pump-out system. Repeat this twice.

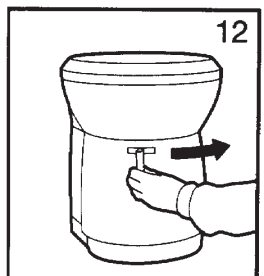
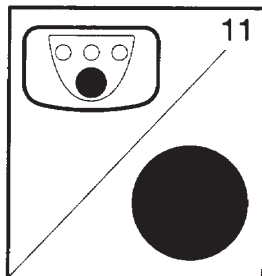
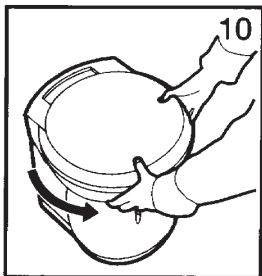
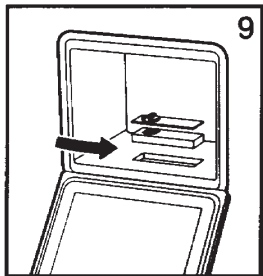
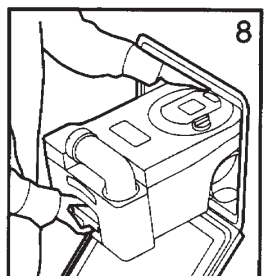
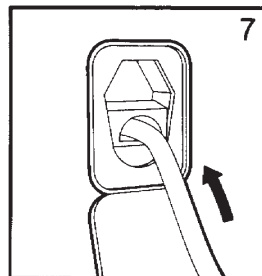
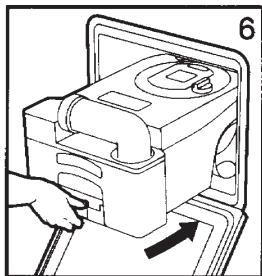
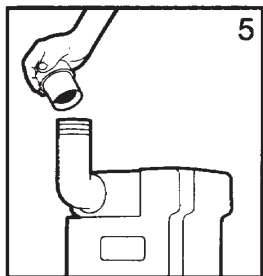
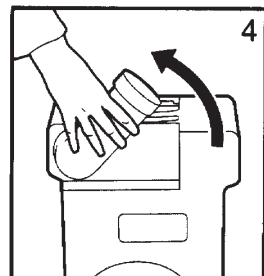
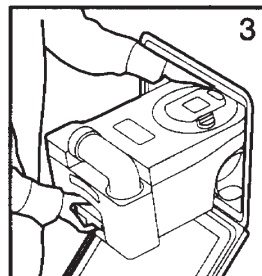
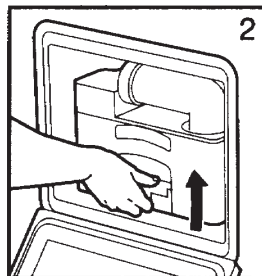
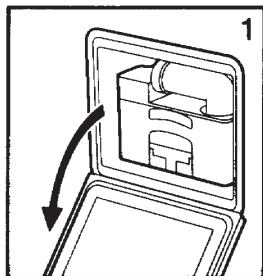



THETFORD TOILETS

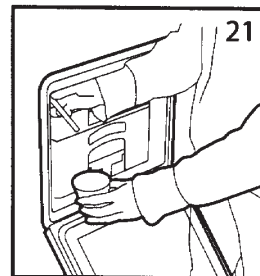
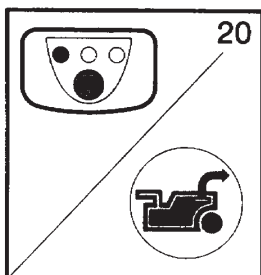
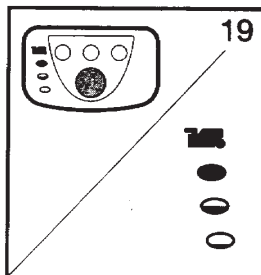
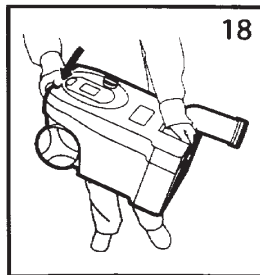
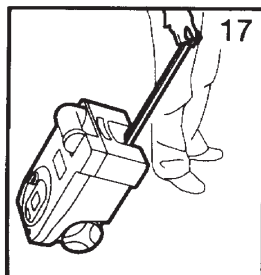
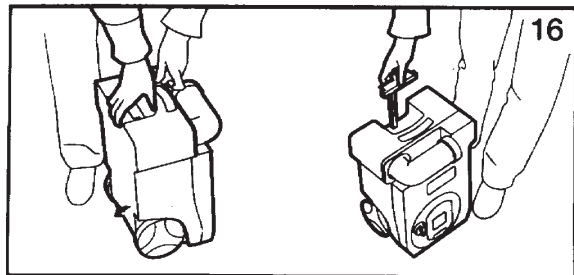
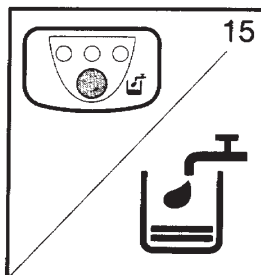
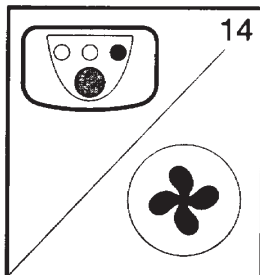
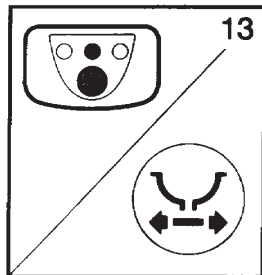

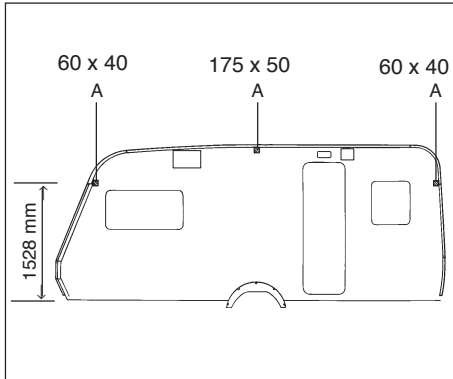

AWNING FIXING POINTS

In all Lunar Caravans fixing blocks for the awning brackets are now fitted as per the diagram (position A). The centre block is determined from centre of wheel arch and just below awning rail.

The end fixing points are just above window height front and rear, approximately 60mm long x 40mm, 1528mm above the underside of the floor (i.e. from top of skirt).

Care must be taken when fixing the brackets and a suitable sealant used.

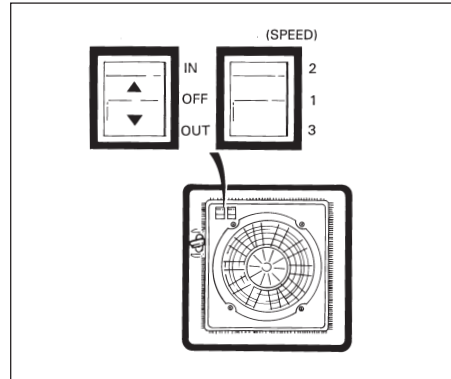

12 VOLT ROOF MOUNTED EXTRACTOR FAN

The fan is a double glazed rooflight. Its side operating mechanism allows a completely free central opening with built-in fixed ventilation when closed.

TILT & SLIDE ROOFLIGHT

To open - turn the handles to release the rooflight. Push it upwards and slide it towards the front of the caravan.

Before travelling ensure the rooflight is in the fully closed and locked position.

A fully adjustable flyscreen and black out screen are built into the frame.

STATUS TV ANTENNA

1. Switch ON the Power Pack and the red LED will illuminate.
2. Check the gain control switch is set to the normal 'NML' position.

Turn on your television set and tune in. This may be necessary at all new locations.

Should you experience problems please refer to the fault finding paragraph.

Removing the Pinnacle

This may be necessary should you wish to reduce the overall height of the antenna by 90mm.

1. Simply unscrew the Pinnacle and remove. The antenna is designed to remain watertight without the Pinnacle.



ANTENNA

2. To replace, simply screw in and tighten **BY HAND**.
3. **IMPORTANT** - The Pinnacle is an integral part of the antenna and critical to its performance. When in use always ensure the Pinnacle is fitted.

Removing the Antenna

A permanently fitted Status may be removed if there are severe height restrictions, leaving only the Mounting Foot in place.

1. Unplug the antenna from the Power Pack. On the Adapter loosen the two grub screws and lift off whilst carefully

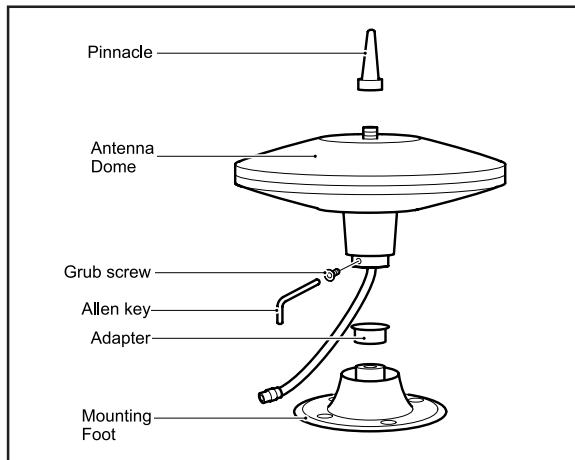

feeding out the coaxial cable with plug attached.

2. Push the Blanking Cap supplied into place to cover the central hole.

FAULT FINDING

The following are some of the key areas we suggest you check which generally sole the most common problems encountered with the operation of the Status antenna.

Coaxial Plugs

It is critical that all coaxial plugs in the system are fitted correctly.

Coaxial Cable

Sharp bends, kinks and hot surfaces can easily damage coaxial cable and should be avoided. An inspection of the cable routing is recommended to ensure all is correct. Coaxial cable, if placed in close proximity to electrical cables, transformers or other pieces of electrical equipment, may pick up electrical interference causing picture quality to deteriorate.

Pinnacle

The pinnacle is essential for the optimum performance of the antenna and therefore should be in place when the antenna is in use.

Gain Switch

Situated below the LED light on the Power Pack, this switch should be set to the normal 'NML' position for general use. The Low setting may be used when situated close to TV transmitters where strong signals may be affecting the quality of the picture.

Red LED Light

Should the red LED on the Power Pack not light, first try unplugging the cable connected to the Antenna Dome from the 'ANT-IN' socket. If the LED then illuminates the fault lies with either the coaxial plug or the coaxial cable, please refer to these areas described earlier.

The Clubman and Delta ranges have the new Status 530, a fully adjustable antenna for height, direction and polarity.

When travelling adjust the antenna so that it points to the rear of the vehicle to reduce the possibility of damage.

For assistance contact your dealer or Grade UK Ltd. Tel: 0115 986 7151.



CHANGING LIGHT BULBS

Wall Lights for Quasar and Ariva range

1. Remove the two cover retaining screws and pull off cover.
2. Exchange bulb by pulling out and pushing in.
3. Replace cover by using reverse procedure.

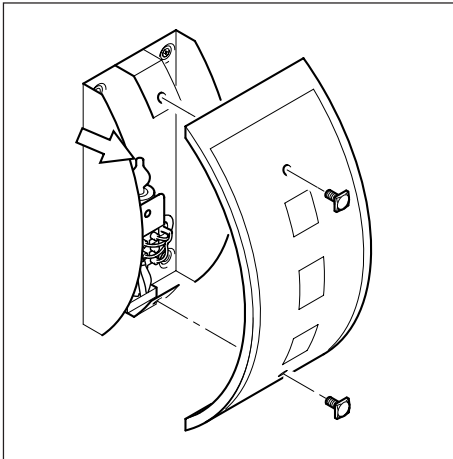

Corner wall lights for Clubman, Delta, Lexon and Stella

1. Remove the two screws in the top corners holding the cover in place.
2. Ease top of cover forward and lift clear of bottom retaining lugs.
3. Exchange bulb by twisting out and replace.
4. Replace cover by using reverse procedure.

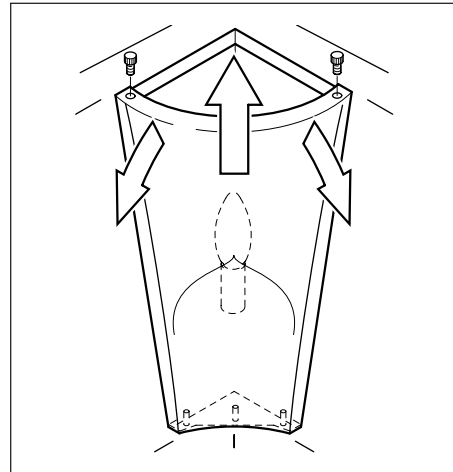

Reading Lamp:

1. Insert a suitable tool, for example a small screwdriver, into the cover slot and prise the cover off the light fitting.
2. Exchange bulbs by pulling out and pushing in.
3. Refit cover, locking in place.

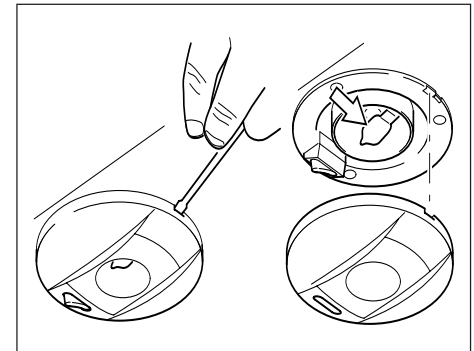



FLYSCREENS & BLINDS

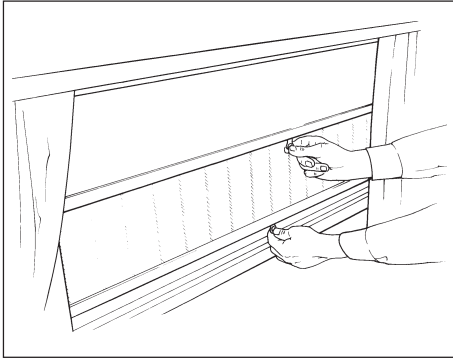

FLYSCREENS AND SUNBLINDS

Important: Blinds should be checked for holes and tears when you take delivery of your caravan. Failure to report a fault at this stage will result in a claim under warranty being rejected.

OPERATING INSTRUCTIONS

Flyscreen

Pull the flyscreen fully down and gently push the crossbar towards the window so that it locates in the retaining “cut out” within the rear channel of the lateral guides. To release, gently pull the crossbar downwards and toward you and allow the tension of the spring mechanism to rewind the flyscreen upwards.

DO NOT RELEASE THE HANDLE – causing the flyscreen to “whiplash” upwards – as this will cause damage to the spring mechanism.

Sunscreen

The front channel of the lateral guides has a number of “cut outs” to enable the sunscreen to be retained at various heights – look inside the lateral guides to locate these. To raise or lower the sunscreen follow similar procedure as with the flyscreen.

TENSION ADJUSTMENT

The tension adjustment clips are located at the left side of the cassette – the top one is for the flyscreen and the lower one for the sunscreen.

Insert screwdriver into tension clip, apply gentle inward pressure and rotate tension clip one or two clockwise turns to increase tension or anti-clockwise to reduce tension. Gently release the inward pressure to enable tension clip to re-engage into its internal ratchet. Check tension and, if necessary, repeat until the crossbars return to their top positions without too much tension or assistance. DO NOT OVERTENSION.

Note: It is not recommended that the window blinds are retained in the “down” position whilst the caravan is being towed.

WINTERISATION

The flyscreen/sunscreen should NOT be left in the “down” position through the winter as this may cause the spring mechanism to lose tension.

However to rectify this, gently pull crossbar downwards and toward you then allow the tension remaining in the mechanism to rewind, when it stops pull the crossbar downwards and upwards five or six times to restore correct tension.

Should the blinds not retract fully, please follow Tension Adjustment instructions.



DOOR FLYSCREEN

1. To close

Pull handle/crossbar across door aperture until hook engages on closing profile.

2. To open

a) **From inside:** To release hook, pull handle/crossbar slightly toward you then, still holding the handle/crossbar, allow the tension to pull the flyscreen back into the cassette.

b) **From outside:** To release hook, push handle/crossbar away from you then, still holding the handle/crossbar, allow the tension to pull the flyscreen back into the cassette.

Caution: To avoid damage to the tension mechanism DO NOT allow the flyscreen to “whiplash” back into the cassette.

3. Cleaning

Use a damp cloth and, if necessary, a normal household cleaner without abrasives or solvents.

Please note:

Do not tow with flyscreen closed.

Do not leave flyscreen closed for long periods (more than 3 weeks).

WINDOW CARE

1. Keeping your acrylic windows sparkling

Small scratches – for small scratches it is possible to use a liquid metal polish such as a proprietary acrylic polish of a suitable grade dependent upon the severity of the scratches.

2. Cleaning

Wash down as you would your car. Do not use a sponge on dirty windows (you wouldn't on your car). When all dirt has been removed, dry with a leather or 'Vyleda' type cloth. The catches and stays do not require lubricating.

3. Check each season

Check whether the seal around the aperture is still firmly fixed to the caravan wall, if not, re-seal with a rubber sealing compound.

CONDENSATION

How to overcome condensation

Condensation occurs when the humidity inside the caravan exceeds 60% and ventilation is not sufficient. To overcome this, take the following action:

1. Improve ventilation

- Leave rooflight open or use a self-ventilating rooflight.
- Add to the ventilation by fitting more improved ventilators.
- Put windows onto night vent position.
- Leave doors open between compartments.

2. Help yourself tips

- Do not wash crockery last thing at night, it creates more moisture in the air.
- Do not boil water last thing at night and empty all water from kettles, etc.
- Remove flowers or vases containing water from sleeping quarters.
- Keep temperature at night to a minimum (hot air contains water vapour).
- Increase ventilation to above normal in inclement or very wet weather.

Note: You cannot expect to eliminate condensation completely but following the hints above will help towards a more comfortable environment.



GRP PANELS/ALARM

CLEANING THE CARAVAN BODY

It is wise to wash the caravan body regularly in order to maintain its good looks. Do not use aggressive cleaning materials as this will damage the paintwork over time. 'T Cut' or other similar cleaning compounds should only be used occasionally for stubborn marks. We suggest that a good quality car wax, applied at least once a year, will enhance the paintwork and ease the cleaning operation.

Glassfibre Reinforced Plastic (GRP)

GRP components need to be washed, waxed and taken care of like a car. Chemicals and dirt can collect during storage, and the gel coat can be stained or marked when chemicals combine with rain or dew. Most stains or marks can be removed with mild dishwashing detergent, but more stubborn marks may require a (fine grit) rubbing compound such as T-cut.

To help keep your GRP components looking almost like new, it is wise to wash the parts monthly (or more frequently) using mild dishwashing detergent, but avoid using strong alkaline (e.g. tri-sodium phosphate) or acidic cleaners or abrasives. Waxing the components once or twice a year with a good grade paste wax will help to maintain the colour and finish.

A significant benefit of using GRP components is the ability to repair most scratches or damage that may be inflicted upon the panel. GRP components are tough, but like any other products they can be damaged. Excessive pressure or impact to the face or reverse of the component can cause the gel coat to crack. This does not mean the entire panel is damaged and the standard industry method of dealing with such a crack is to apply a minor repair.

Any scratches or nicks that occur in normal use can usually be removed with rubbing compound. If the scratch is too deep, then (fine grade) wet sandpaper may be used followed by rubbing compound and finally wax.

One of the characteristics of GRP is the way light may be transmitted through the component. If the component is viewed from the gel coat side it will appear opaque and of a solid colour. However, if viewed from the reverse side with a strong light source behind the laminate, some light will be transmitted. This is normal for components of this thickness.

BADGES

Resin coated badges are now being widely used within the caravan industry. Their upkeep is simple, use soap and water only to clean them. Under no circumstances should abrasive cleaners or solvent based solutions be used on them.

LUNAR PROTECTOR CARAVAN ALARM & LIGHT CONTROLLER WITH REMOTE CONTROL

Your caravan has been fitted with a Lunar Protector alarm system. This provides comprehensive protection for your caravan, when parked or coupled to your tow vehicle, as well as protecting the contents. The alarm system is controlled by a key fob, which can also switch the awning light on/off. When the alarm is on, pressing both fob buttons sounds the siren (panic alarm). If you insure with the Caravan Club, K. Drewe (Insurance) or Caravan Guard Insurance, you should be eligible for a discount on your premiums.

Preparation for use

The caravan must be fitted with a 12 volt leisure battery for the alarm system to work.

The key switch on the control box should have been left in the clockwise position, otherwise the alarm will not work.



Using the alarm

Press the "alarm" button on the key fob for a couple of seconds to switch the alarm on. The siren will "cheep" twice so you know that the alarm has been activated. Should a thief trigger the alarm the siren will sound for two minutes and reset. On your return switch the alarm off by pressing the "alarm" button on your key fob for a couple of seconds. The siren will "cheep" once so you know the alarm has been de-activate.

When using the alarm with the caravan coupled to your tow vehicle (for example at motorway service areas) remember to switch the alarm off on your return, otherwise the first time you use the foot brake you will trigger the alarm siren.

To switch the awning light on/off press the "light" button on the key fob. (Please note that this light must be switched on with its own switch before it can be switched off then back on using the key fob.

Testing the alarm

Once you have switched the alarm on and the siren has "cheeped" twice, any one of the following actions will trigger the siren for two minutes or until the alarm is switched off:

- Winding the alarmed rear leg.
- Coupling up and inserting the 12N or 13 pin plug.
- When coupled, unplugging the 12N or 13 pin plug.
- When 12N or 13 pin plug inserted, using the foot brake.
- Entering the caravan (instant operation).
- Disconnecting the leisure battery.
- Pressing both fob buttons together (panic alarm). Alarm must be switched on first.



BUNK BEDS

BUNK BED ASSEMBLY

The following step by step guide illustrates how to assemble the bunk bed.

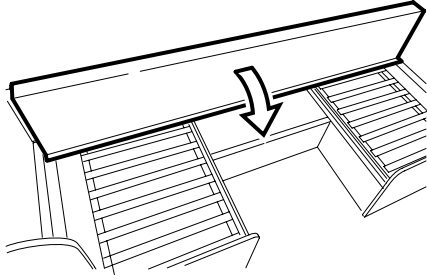

1. Pull the top edge of the bunk towards you.

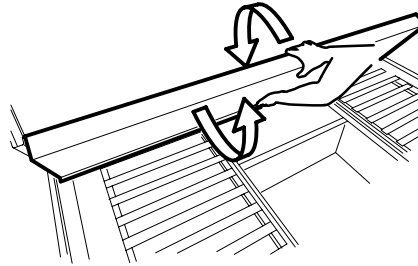

2 & 3. With your left hand on the bottom edge, lift upwards and towards you, while your right hand keeps the bunk steady.

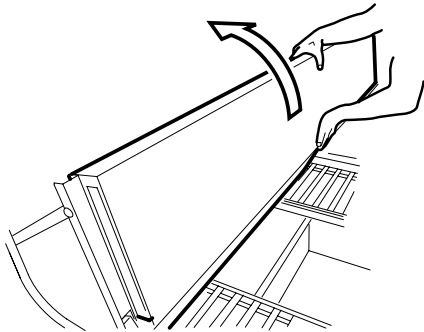
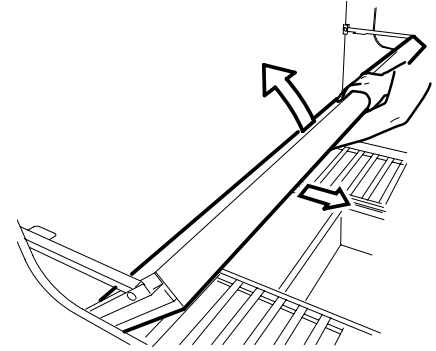

4 & 5. As the left hand passes the pivot point allow the right hand to slowly lower the bunk into the rest position.

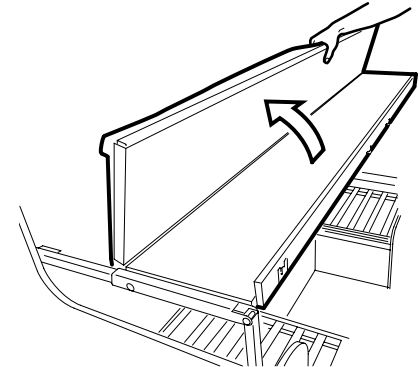
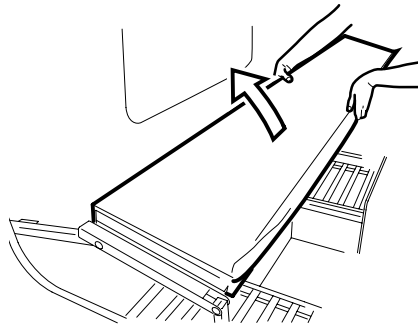

6. Fold the two part bunk into position.

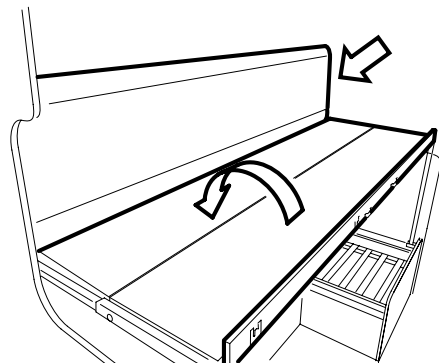

7. Fit the safety boards into position.

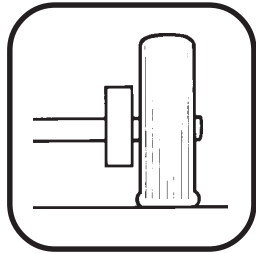

AL-KO CHASSIS & TYRES

Chassis	98
Running Gear	98
Braking System	98
General Maintenance	101
Tyres	102



AL-KO CHASSIS & TYRES

CHASSIS & UNDERGEAR

The Chassis

The design of the chassis undergear is suitable for the sustained high speeds permissible on mainland Europe (130 k.p.h.).

The maximum static load at the coupling head is 100kg.

The chassis is capable of carrying your caravan to the Maximum Technical Permissible Laden Weight as shown at the back of the service handbook.

The towing hitch (50mm dia. ball) operates on the over run principle; the application of the towing vehicle brakes automatically, mechanically operating the brakes of the caravan.

No manual assistance is needed to activate the auto reversing mechanism which automatically comes into operation when the towing vehicle starts to travel in a reverse direction. No lock off device needs to be used.

As the name implies, the corner steadies are designed to steady and stabilise the caravan when parked. They are not designed as jacks.

The AL-KO chassis is galvanised steel. To maintain protection to the steel, any rusting areas should be recoated using galvanising paint.

ALKO RUNNING GEAR

Coupling Head

The ball couplings are entirely automatic in operation and designed for one hand operation to suit the 50mm international ball recommended by the British Standards Institution, National Caravan Council and the Society of Motor Manufacturers and Traders.

It is expressly forbidden by the chassis manufacturer for holes to be drilled into the 'A' frame to accommodate a stabiliser bracket. A clamp must be used. Similarly, holes should not be drilled into the coupling head.

Operation of hitch head *(also see page 10)*

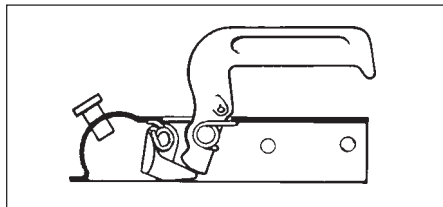

Lift handle upward and forward. Place the unlocked coupling onto the towing ball and with the slightest downward pressure it will lock onto the ball automatically. Ensure locking trigger returns to its free position and indicator button shows green before commencing to tow.

Uncoupling

Having lowered the jockey wheel to the ground, operate the handle as previously described. Lift the coupling clear of the towing ball either manually or by operating the telescopic jockey wheel.

BRAKING SYSTEM (AL-KO Automatic Reversing Brakes)

Forward Braking

In the free position, with the drawshaft fully extended and the handbrake lever fully forward "off position" the wheel brake shoes are clear of the drum and there is no friction.

During braking travel on the main shaft of the overrunning device is transmitted via the overrun lever, brake rod and bowden cables to the expander mechanism inside the wheel brake. The fully floating expander mechanism (2) forces the leading brake shoe (1) and by reaction the trailing brake shoe (3) into contact with the brake drum.

The friction between brake shoes and drum creates a tendency for both shoes and expander to move with the forward rotation (4) against the solid abutment of the adjuster box (5) which ensures both shoes remain in the braking position.



Reversing

During reversing the shaft of the overrunning device is subjected to its full travel which is transmitted in the normal manner to the expander mechanism inside the wheel brake.

The expander (2) forces both brake shoes (1 and 3) into contact with the drum as normal except with the backward rotation of the wheel the friction between brake shoes and drum is relieved.

The initial friction between brake shoes and drum ensures that both shoes plus the expander mechanism show a definite tendency to move in the direction of rotation i.e. reverse. The pressure generated by this action is applied to the spring loaded reverse lever (6) which is attached to the adjuster box (5) causing it to collapse.

The collapse of the reverse lever virtually eliminates the friction between brake shoes and drum thus allowing easy reversing. With only slight forward movement, the reverse lever returns to its normal position by virtue of the coil spring attached, and normal braking is immediately available.

Parking — Handbrake Application

The AL-KO automatic reversing brake system incorporates a patented device for added safety when parking on a reverse sloping site or a steep hill.

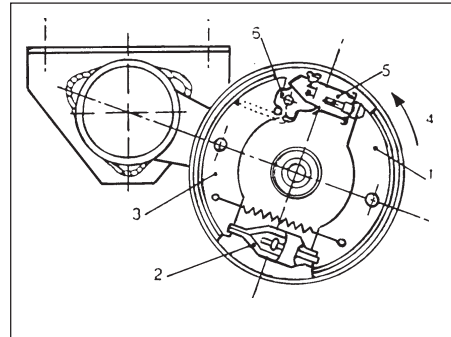

A spring cylinder has been added to the link between handbrake lever and centre brake rod.

Full application of the handbrake lever, i.e. as near vertical as possible, compresses a coil spring inside a steel cylinder and should any movement of the caravan occur following uncoupling the energy stored in the spring is immediately released to lock the wheel brakes.

It should be noted that it is good common practice to chock the wheels of a caravan when parking on steep slopes, or under adverse conditions such as loose or slippery surfaces.

AL-KO Trailer - Control (featured on Clubman and Delta range)

AL-KO Automatic Trailer Control is an electronic control system that reacts quickly to maintain the stability of the car and caravan. The system continually monitors the stability of the caravan during a journey and operates when an unstable condition is encountered. When AL-KO ATC activates, the driver will feel the vehicle being slowed down by the soft braking of the caravan.



AL-KO CHASSIS & TYRES

AL-KO ATC LED OPERATION

Display Colour	ATC Condition	Diagnosis	What to do	Outcome	Status
Green	ATC Active	Everything OK	Drive forward to detect movement to complete self test and recheck LED	Green (Constant)	Ready for journey
Green Flashing	ATC Active	Self test incomplete			
Red	ATC Inactive	Possible to continue journey	Remove 12S or 13 pin plug and wait five seconds.	Green	Ready for journey
			Reconnect plug	Red	ATC fault detected but can be driven
Red flashing	ATC has detected a fault	Do not continue with ATC connected	Remove 12S or 13 pin plug and wait five seconds	Green	Ready for journey
			Reconnect the plug.	Red (flashing)	ATC fault detected cannot be driven. Remove pushrod

Flashing Green - Simply the ATC is waiting to detect movement. Drive a few metres and the light will change to green.

Flashing Red - To provide further explanation if the constant RED light is showing: There are a number of errors that the ATC logs and some are self repairable by the customer but some will require the ATC to be monitored by the diagnostic equipment that is available and the AL-KO service engineers are trained to use.



GENERAL NOTES ON MAINTENANCE

Tyre Wear and Damage

The legal requirements for tread depth on motor vehicles apply also to caravans. In order to equalise wear it is suggested that wheels be balanced and changed around from time to time.

It is dangerous to neglect tyre damage and should you detect a blister, rupture or cut exposing the casing, or if it has suffered a violent impact (for example against a kerb), such that there is a risk of internal damage, it is advisable to have it examined by a tyre specialist as soon as possible.

Wheels

The condition of wheels should be checked regularly particularly for distortion of flanges and the wheel dish. Wheels dam-aged or distorted, or having wheel bolt seatings cracked or deformed must not be repaired.

Couplings

1. Clean and grease spherical seat, bearing parts and pivot pins regularly.
2. Thoroughly examine all moving parts for wear and correct functioning.
3. Couplings should never be drilled.

Towing Ball

The automobile towing ball should measure

50mm maximum and 49.5mm minimum (DIN 74058). If the ball is found to be worn it should be replaced immediately.

Overrunning Device

The device housing is packed with grease on assembly, but will require periodic maintenance to ensure smooth operation of the braking system.

1. Regrease the shaft bearings via the grease nipples provided at 3000 mile intervals and before storage.
2. Ensure correct functioning of all pivot pins and levers and oil regularly.

Jockey Wheel

Lubricate wheel and screw thread periodically.

Brake Linkage

All moving parts should be lubricated periodically to ensure their satisfactory operation.

It is recommended that all brake linkage threads are liberally smeared with grease for protection and as an aid to future adjustment of the system.

Corner Steadies

The screw and pivot pins should be lubricated periodically to ensure their satisfactory operation.

Braking System

At 500 miles then every 3000 miles or 1 year check and adjust brake linkage to compensate for any stretch of the bowden cables.

Check and adjust wheel brakes to compensate for wear.

IMPORTANT When replacing the wheels you should tighten the nuts in rotation diagonally, taking care to tighten them equally.

The recommended torque is 88Nm (65lbs/ft) for steel wheels. Alloy wheels should be 115Nm (85lbs/ft).

CHECK THE WHEEL NUTS BEFORE STARTING EVERY JOURNEY

IMPORTANT NOTICE:

The caravan is manufactured for towing behind road cars and the 4 x 4 "off road" type of passenger car derivative. THE CARAVAN IS NOT SUITABLE FOR TOWING BEHIND COMMERCIAL VEHICLES.



AL-KO CHASSIS & TYRES

TYRES

PREPARATION

Tyres & Tyre Pressure

Safe driving and handling when towing a caravan is very important and one major factor which is frequently overlooked is the tyres. Look after your tyres properly and you will improve the safety and behaviour of your car and caravan.

Check the Pressures

Whatever tyres are fitted to the towing car and caravan it is essential to the safety and stability of the combination that all tyres are correctly inflated. This is a 'golden rule' of motoring and of caravanning in particular.

Pressures should be checked when the tyres are cold, not warm during or just after a run when they will be higher. Never reduce pressures when tyres are warm as they could be too low when they cool down.

The tyres specified by the caravan manufacturer are satisfactory for towing in the UK and are rated up to 80mph (130kph) at the maximum design weight of the caravan. In certain countries overseas it is legal to tow at higher speeds. If it is intended to visit such countries and tow up to the higher speed limits then it is important that the suitability of the tyres is first checked with a caravan dealer.

Tyres & Pressures

The tyres fitted, and the pressures needed, vary from model to model. Check the Service Handbook for specific recommendations for your model.

The speed limit for towing a caravan in the U.K. is 60mph. If a tyre needs to be replaced you must ensure that you refit a tyre of the same specification. The correct pressure for your car tyres will be found in the car handbook.

Fit the Right Tyres

As with all road vehicles it is always advisable to have the same type of tyres on all wheels i.e. both on the towing vehicle and the caravan but it is recognised that caravans and trailers will frequently have a different type from the towing vehicle.

If a wheel or tyre has been changed the replacement has to be of the same type of construction and size as on the other wheels.

General Recommendations

Because caravan tyres and wheels are rarely the same as those on your car you must not attempt to use the car wheel on your caravan if you should have a puncture.

Check your tyres regularly but particularly when the caravan has not been used for a long time. Vehicles such as caravans if not used in the winter should be thoroughly inspected prior to re-use during the summer months. Look particularly for any signs of age deterioration in the tyres such as sidewall cracking and carcass deformation. Tyres on a stationary vehicle, particularly if parked in coastal areas, always age and crack more quickly than those which are run frequently and, if your caravan is going to stand for a long time it is a good idea to cover the tyres with old sacks, etc. to shield them from direct light and, if possible, to jack the weight off the tyres. If in doubt at all about your tyres have them checked immediately by a tyre distributor.

WARNING: Prior to any journey the condition of the tyres should be inspected. The NCC recommend that tyres are replaced seven years from date of manufacture at the very latest.

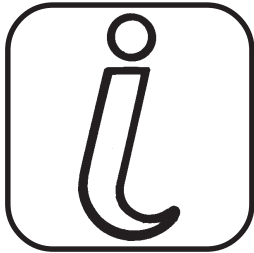

GENERAL DATA

Wiring Diagrams	104
Wiring Diagram – Road Lighting	107
Light Bulb Replacements	108
Security	108
Owners Club	109
Owners Warranty	109
Winterization Guide	110



GENERAL DATA

STANDARD LUNAR PRIMARY CIRCUIT DIAGRAM

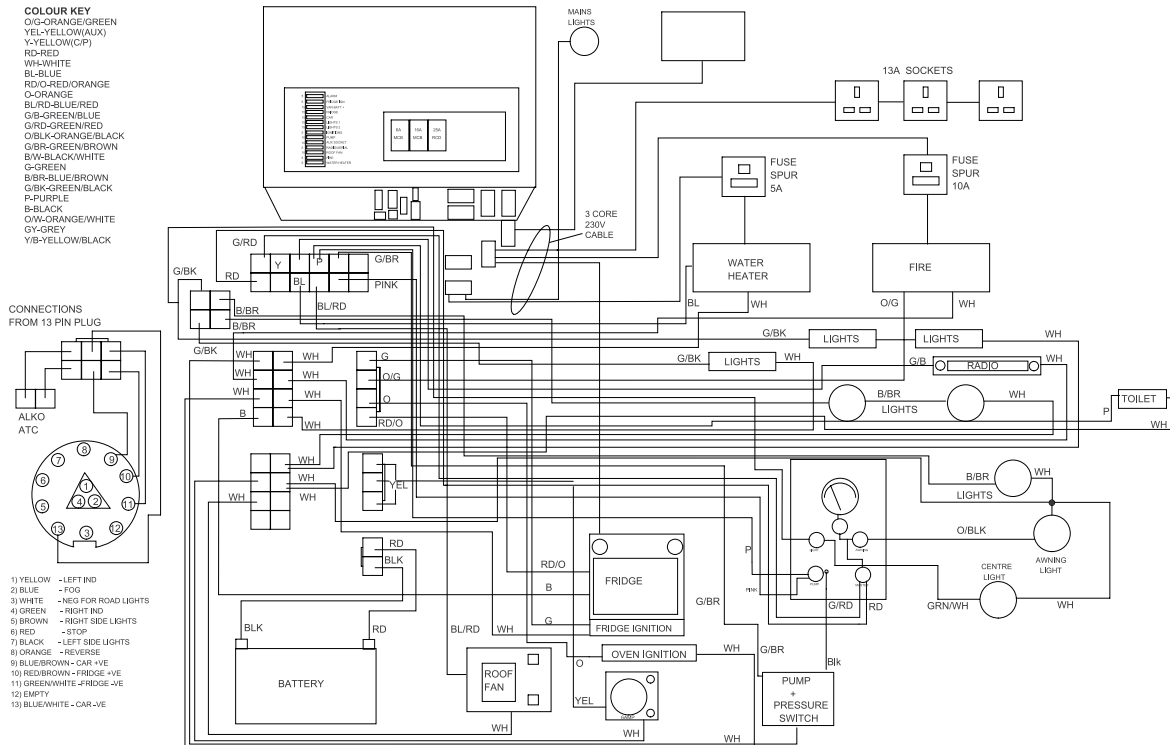



CLUBMAN LUNAR PRIMARY CIRCUIT DIAGRAM

- COLOUR KEY**
- O/O-ORANGE/GREEN R/B-RED/BROWN
 - YEL-YELLOW(AUX) WH/B WHITE/BROWN
 - Y-YELLOW(C/P)
 - RD-RED
 - WH-WHITE
 - BL-BLUE
 - RD/O-RED/ORANGE
 - O-ORANGE
 - BL/RD-BLUE/RED
 - G/B-GREEN/BLUE
 - G/RD-GREEN/RED
 - O/BLK-ORANGE/BLACK
 - G/B/R-GREEN/BROWN
 - B/W-BLACK/WHITE
 - G-GREEN
 - B/B/R-BLUE/BROWN
 - G/BK-GREEN/BLACK
 - P-PURPLE
 - B-BLACK
 - O/W-ORANGE/WHITE
 - GY-GREY
 - Y/B-YELLOW/BLACK

CONNECTIONS FROM 13 PIN PLUG

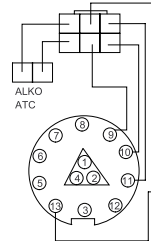

- 1) YELLOW - LEFT IND
- 2) BLUE - FOG
- 3) WHITE - NEG FOR ROAD LIGHTS
- 4) GREEN - RIGHT IND
- 5) BROWN - RIGHT SIDE LIGHTS
- 6) RED - STOP
- 7) BLACK - LEFT SIDE LIGHTS
- 8) ORANGE - REVERSE
- 9) BLUE/BROWN - CAR +VE
- 10) RED/BROWN - FRIDGE -VE
- 11) GREEN/WHITE - FRIDGE -VE
- 12) EMPTY
- 13) BLUE/WHITE - CAR -VE

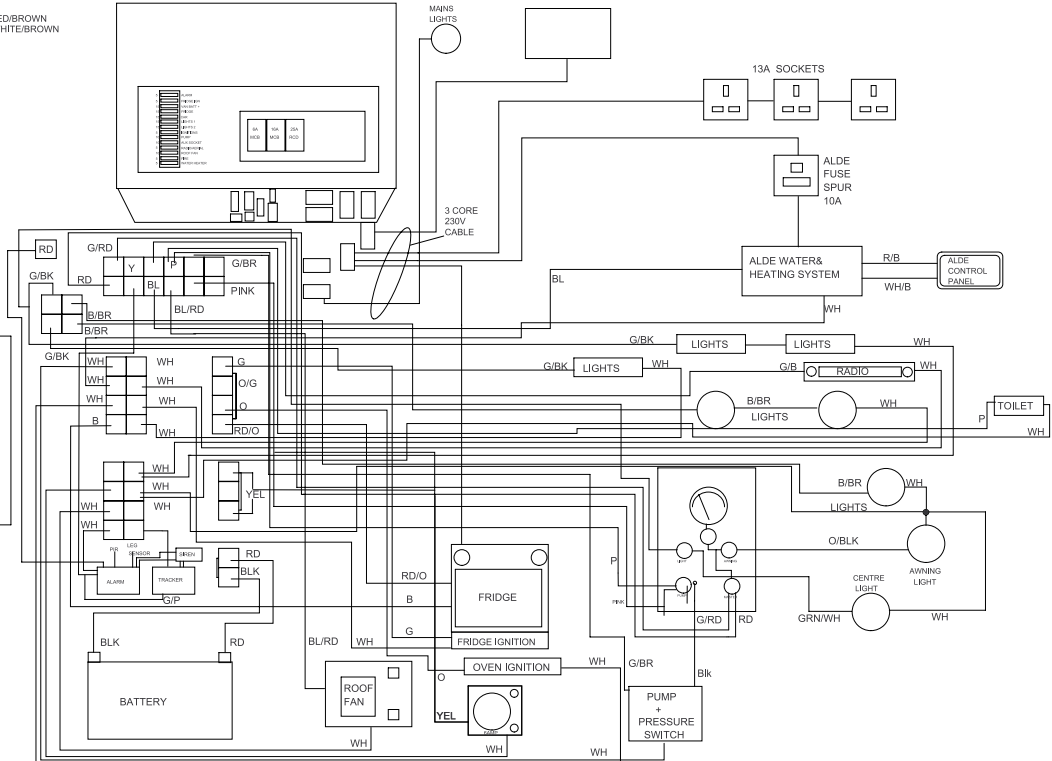



GENERAL DATA

DELTA LUNAR PRIMARY CIRCUIT DIAGRAM

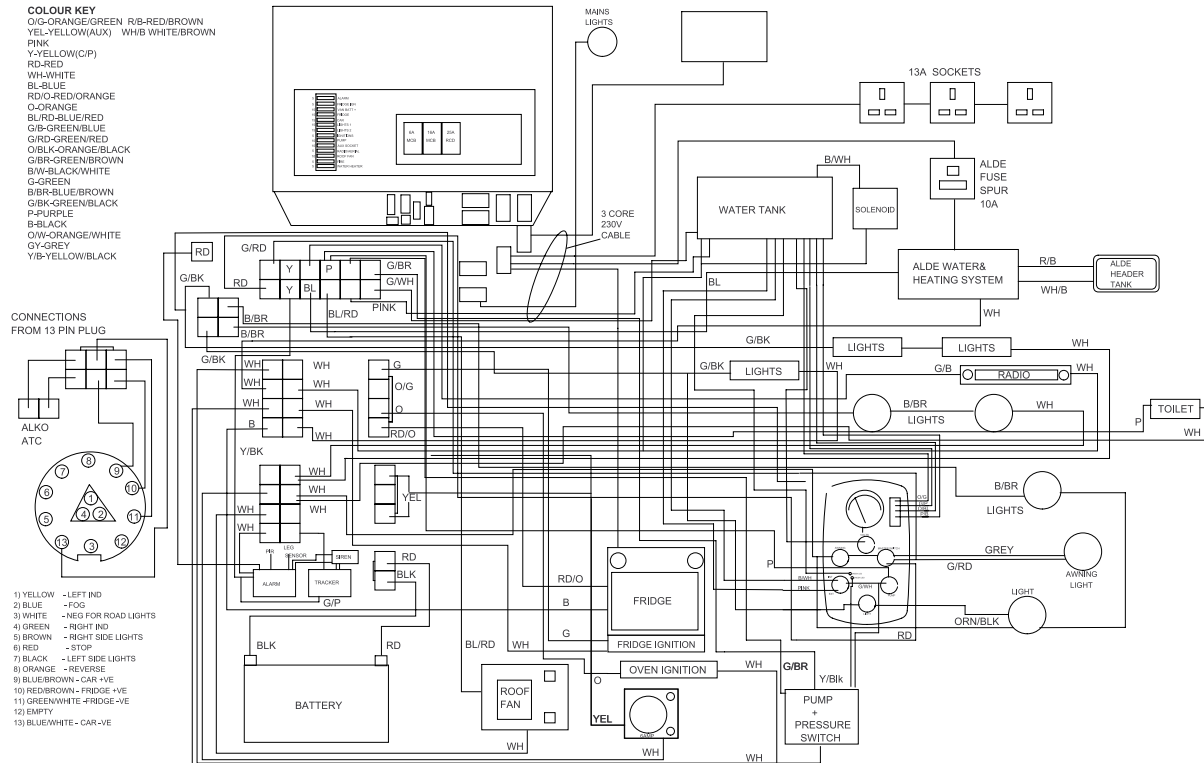



ROAD LIGHTING WIRING DIAGRAM

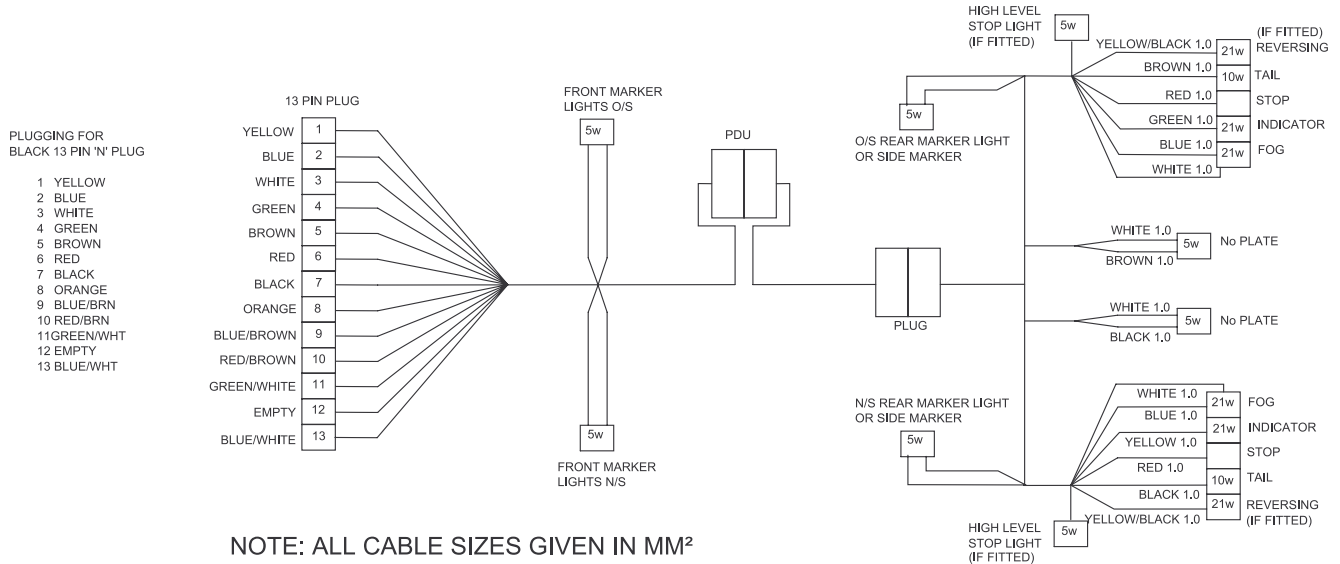



GENERAL DATA

LIGHT BULB REPLACEMENT

Brake/side light	Twin 21W/5W, 12V
Front side light	5W, 12V
Side light (white/red)	5W, 12V
Indicator light	21W, 12V
Reversing light	21W, 12V
Fog light	21W, 12V
High level brake light	12V LED
Number plate light	5W, 12V
Spotlight	10W Halogen
Mains Reading Light	40W
Ceiling Light	2 x 10W, 12V Halogen
Toilet ceiling light	10W, 12V Halogen
Awning Light	12V x 24 x LED Strip (None replaceable bulb)
Cocktail Cabinet	12V 6 x 0.06W LED (None replaceable bulb)
Spot light	12V 1 x 1W LED (None replaceable bulb)
Mood light 195mm	12V 10 x LED Strip (None replaceable bulb)
Mood light 550mm	12V 20 x LED Strip (None replaceable bulb)
Bunk light	5W, 12V Halogen
Courtesy light	12V LED (None replaceable bulb)
Reading lamp	10W, 12V Halogen
Reading lamp	12V 1 x 1.2W LED (None replaceable bulb)
Heki light	4 x 5W, 12V
Front interior corner light	40W, 230V
Front wall light	25W, 230V

SECURITY

Ensure that you lock all windows and doors when leaving your caravan. Fit a towbar hitch lock or a wheel clamp -consult your dealer on all safety and security recommendations.

Keep your gas cylinder locked when leaving your caravan.

Many devices are available to alarm your caravan. It is a good idea to mark your caravan in a secret place -this will help the police to identify it should it be stolen.

Caravans can be stolen from storage compounds, motorway service areas and even your own premises, so it is always wise to be vigilant at all times. Ask your dealer about details on all security aspects.



LUNAR OWNERS CLUB

Now you are the owner of a Lunar caravan why not join the Lunar Owners Club.

This is an independent club run and organised by owners.

Lots of opportunities exist to make new friends at social gatherings and Rallies both Regional and National.

We hope that you will enjoy your caravanning and any comments are welcome in order to improve design and comfort.

A leaflet regarding the Owners Club is within the wallet, if it is not please contact Lunar and a copy will be sent to you.

Alternatively for further information please visit the Lunars Owners Club website at: www.lunarsownersclub.net

OWNERS WARRANTY

Lunar Caravans Limited hereby warrants, subject to the terms, conditions and exceptions shown within the separate Service handbook, that any failure of parts and components will be repaired or replaced by the approved dealer from whom the caravan was purchased.

We expect your new Lunar caravan to provide long and trouble free service, even so, it is vital that you understand the contents and follow the correct procedures, to ensure you receive the full benefit of this added protection.

Your legal rights are neither affected nor prejudiced against the supplying dealer and/or the manufacturer.

All Lunar Caravans are supplied with a 6 year body shell integrity warranty and a 3 year manufacturers backed warranty from the date of purchase which is conditional on annual servicing being carried out within 60 days either side of the anniversary of the purchase date, except the third service which should be carried out prior to the 3rd anniversary date of the final year.

Validating your warranty

To validate your warranty, you simply need to register your caravan purchase with us at www.lunarcavans.com. By registering your details we will be able to assist you more easily should you make a warranty claim.

Before you register please make a note of your caravan's 17 digit VIN Number and your 3 digit Registration Security Number.

The VIN number, beginning SGL, can be found on the windows. The Registration Security Number can be found on the Theftford Model Label located inside your fridge or oven. The Model Label has a Serial Number or SER. NO. and the **last 3 digits** of this number will form your Registration Security Number.

Please note that your oven and fridge will have different Serial Numbers to each other, but you can use the last three digits from either one to register your van.

Once your details have been submitted, you will be sent email confirmation that they have been successfully received.

Additional equipment

If additional equipment (other than those on the optional list of Lunar) is to be fitted you should check with your dealer beforehand. The warranty may be invalidated.

Vermin

Vermin can gain access via the smallest of holes. Lunar fit grills and grommets to prevent this but the nature of some caravan storage means it can happen, with upsetting results. We advise setting a trap and/or poison and regular inspection.

Vermin damage is not covered by warranty.



GENERAL DATA

CARAVAN WINTERIZATION GUIDE

If the caravan is to be stored for any length of time, the following procedure is advisable:

1. Location

If possible avoid siting the caravan beneath trees or near dilapidated buildings, where strong winds may dislodge branches or slates that can damage the caravan. In exposed conditions ground anchors may be advisable. Be wary of low lying areas that may be prone to flooding.

2. Covers

Large polythene or tarpaulin sheets should not, in the opinion of most experts, be used to 'seal' the caravan against the elements. Condensation and mould growth may be encouraged and any flapping material or guy ropes could scratch acrylic windows.

If you feel a cover is absolutely necessary because of where the caravan is parked, however, purchase one that is made of "breathable" material.

3. Ventilation

Caravan vents should be left uncovered to provide adequate air circulation inside the caravan; however if in an exposed or salty location the vents on the side of the prevailing wind and/or the 'fridge vent may be closed off for the winter. If you have

regular access to the caravan, you could place some moisture absorbing crystals in cupboard corners to reduce the risk of condensation, but these will require fairly frequent changing. There is also a low wattage heater which maintains a low level of localised background heat, minimising damp and condensation and keeping the worst of the chills at bay.

4. Interior

To prevent possible mould growth over the winter, clean and vacuum carpets, curtains and upholstery and if possible remove the soft furnishings and store in a warm, dry place (eg attic). If not possible to remove the cushions, store on edge away from the caravan walls, allowing air to circulate around them and cover with an old sheet to prevent fading in the sunlight.

Walls and ceilings should be wiped over with a mild anti-bacterial solution (eg Dettol) and can be polished afterwards if desired. Cupboards should be emptied, cleaned and vacuumed out. Small doors can be left ajar to assist ventilation, but larger doors should be closed or they may warp.

The refrigerator should be emptied, cleaned with a solution of bicarbonate of soda or anti-bacterial solution and the door left ajar.

The hob/oven should be thoroughly

degreased and cleaned. If using one of the stronger oven-cleaners on the market be sure to allow plenty of ventilation whilst working. If necessary burner jets can be brushed over with a stiff brush, and blockages cleared with a high-pressure air line. Never try to clear blocked jets with a piece of wire which can damage or enlarge jet holes.

Water heaters must be drained and care must be taken to remove any lurking pools of water or frost damage may result. If possible blow air through the heater to push any water droplets through. Leave drain taps and inlets open.

The water pipes can be flushed through with a proprietary sterilising agent and the waste pipes with a stronger disinfectant. Make sure the water pump is drained and remove the water filter. Fresh and waste water containers should be cleaned, drained and stored with caps loose or off. Leave all water inlets and outlets open, but they may be covered with a fine mesh material (eg stocking) to prevent entry of insects etc.

The toilet should be cleaned according to the manufacturer's instructions, using a suitable disinfectant for the holding tank. Rinse all sections thoroughly and store unsealed. Any rubber seals or diaphragms can be lubricated with olive oil to prolong life.

5. Battery

Unless powering an alarm system, the 12v battery should be removed, wiped over, the terminals cleaned and smeared with petroleum jelly. The electrolyte level should be checked and topped up with distilled water if necessary. Trickle charge from the mains until you obtain a reading of 12.6v on a voltmeter or 1.27 on a hydrometer. Store the battery in a cool, dry place and check the state every 6-8 weeks. Top up the charge as required.

Electric clocks, smoke detectors etc, if fitted, should have their internal battery removed. Battery powered burglar alarms may benefit from a new set of batteries for the winter.

6. Awning

The awning should be spread out on dry grass or concrete and brushed with a broom to remove any mud. If the canvas is stained try removing the marks with a stiff brush and plain water. If this fails pure soap flakes can be tried, which will mean re-proofing is necessary afterwards, but never use detergents. If stains are stubborn there are proprietary cleaners such as Fabsil Universal Cleaner, available from caravan accessory shops, or contact Grangers International Tel: 01773 521521. Any mildew spots can be treated with a weak solution of hydrogen peroxide – scrub into the affected area and allow to dry before re-proofing (spot test a

hidden area in case colour is affected). Such severe treatment will weaken the awning material so live with stains if you can! Clear windows can be cleaned with methylated spirits if water doesn't work, but nothing stronger. Examine seams and repair any broken stitching and replace perished rubber tensioners. Give the awning a good shake and pack it when completely dry, trying not to put too many creases in the window. Store in a dry, vermin free area.

Awning poles need little attention other than a wipe down with a damp cloth. Don't oil or grease them as this may get onto the canvas. Pegs can be cleaned and straightened and any badly damaged ones can be replaced ready for the next season.

7. Exterior

Look over the rubber window seals and replace any that look perished. Coat serviceable rubbers with olive oil. If you have a damp meter check around the inside for any trouble spots and re-seal suspect joints. Any major damp penetration problems should be resolved before storage. Minor leaks might be cured using Captain Tolley's Creeping Crack Cure. Major leaks require complete renewal of the sealant; both products should be available from caravan accessory shops.

The caravan body will benefit from a

thorough clean using a car shampoo (household detergents are corrosive) and a coating of good quality polish. Take care when washing the windows as they scratch quite easily. Small scratches can be removed using a liquid metal polish such as Brasso. Duraglit wadding may also prove successful, and Farecla Products make a polish especially for use on acrylic windows – telephone Farecla Products Ltd on 01920 465041 for nearest stockist. Door locks and hinges can be squirted with WD40, wiping off any excess. Fenwick's Overwintering Caravan Storage Fluid protects against algae, mould, airborne pollutants, acid rain and bird lime, available from selected caravan accessory shops or contact Fenwicks Tel: 01270 610161.

8. Chassis

The chassis should be brushed off, or if exposed to corrosive elements, eg road salt, thoroughly washed down. Any surface rust can be removed with a wire brush or sandpaper and the chassis and axle tube can be painted with a rust inhibitor, suitable paint (eg Hammerite) or Finnigan's Waxoyl. The coupling and all winding mechanisms should be degreased, examined for wear then re-greased.

9. LPG cylinders

LPG cylinders should be removed and stored



GENERAL DATA

in a cool, ventilated location. Some storage compounds will insist they are removed to comply with fire safety regulations. The regulator and/or pipe end can be covered with a stocking or similar to prevent the entry of debris or insects that can block the gas supply.

10. Electrics

13 pin, 12N and 12S plugs should be inspected and cleaned and the pins coated with vaseline. WD40 should not be used as it may 'melt' some plastics on contact. The plugs should be protected from the weather but not fully sealed in polythene which will encourage condensation. Road lights should be checked and any water ingress cured, full inspection and cleaning can be done now or left to the springtime service.

11. Axle stands

Ideally the caravan should be jacked up and supported on axle stands with the wheels clear of the ground. Wheels can be removed if desired and stored in a cool, dark place at normal inflation pressure. Inspect tyres carefully and make a note to renew any suspect ones before using the caravan again. The corner steadies should be lowered and rested on blocks if they do not reach the ground. The handbrake should be left off and the wheels rotated from time to time to keep the bearings lubricated.

12. Security

Finally remove any valuables and documents from the caravan to make it secure; thieves do not hibernate for the winter!

Please note that neither Lunar Caravans Ltd nor The Caravan Club endorse any of the listed products and you should satisfy yourself as to their suitability. As always, check that the installation of an after-market accessory does not invalidate your warranty.

A		F		N		V	
Alarm (Delta & Solaris)	92	Fire Action	28	Noseweight	6	Vermin	109
Arrival on Site	24	Fire Extinguisher	29	Number Plate	19		
Levelling the caravan	24	Fire Precautions	28	O		W	
Siting/Unhitching	24	Flyscreens	90	Oven		Warranty	
ATC (Automatic Trailer Control)	99	Fuses	107	Grill	66	Extended Warranty	109
Awning Fixing Points	87			Hotplate burners	65	Owner's Warranty	109
B		G		P		Validation	109
Battery	52	Gas	39	Pre-load Checklist	8	Water Heater	56
Blinds	90	Gas Bottles	39	Pre-tow Checklist	10	Electrical Operating Instructions	58
Breakaway Cable	17	Gas Safety Advice	41			Gas Operating Instructions	57
Bulb Replacement	108	Precautions	41	R		Water filter	59
		Types of Gas	40	Refrigerator		Water System	
C		General Data	108	Thetford N97, N112 & N175	60	Helpful Hints	38
Caravan Handling	22	Lunar Owner's Club	109	Reversing	22	Pressure Switch	38
Caravan Towing Code	4	Security	108	Road lighting	20	Setting Up the Water System	37
Chassis & Undergear	98	Servicing	109			Wheel Changing	23
AL-KO Running Gear	98	H		S		Wheel Lock	13
General Notes on Maintenance	101	Heating		Security	30	Wheels	
Circuit Diagram		Alde	74	Datachip Security Card	30	Torque	18
Delta	106	Truma Ultraheat	72	Vehicle Identification Number (V.I.N.)	30	Window Care	91
Lunar	105	Trumatic S3002	70	Smoke Alarm	28	Winterization Guide	110
Standard	104			Speed Limits	22	Wiring Diagrams	107
		J		Stabiliser, AKS2004	11		
D		Jacking Points	23	Stability	9		
Distribution of Weight	8	L		Stabilisers	9		
E		Lighting		Sterilising	35		
Electrics	43	Corner wall lights	89	T		Toilet	
13 pin wiring diagram	20	Reading lamp	89	Cassette Toilet C-250 CWE	79	Cassette Toilet C-402	76
230V Mains Electric Equipment		Wall lights	89	TV Antenna	87	Tyres	18, 102
Usage	43			General Recommendations	102	Tyres & Pressures	102
Control Panel	50	M					
Delta Control Panel	50	Mains Power Unit	48				
Instructions for Electricity Supply	43	Mirrors	19				
Power Distribution Unit	48	Motorway Driving	22				



NOTES

Publication Designed and Produced by Preset Graphics
Tel: 01332 549278. Fax: 01332 549279. E-mail: Presetgraphics@btconnect.com
Ref: 21182 © All Rights Reserved